



FREEZER

Remote Freezer, Thermistor

The ACI Thermistor Freezer Series features a 3/16" diameter stainless steel probe with a 30 Foot, 3 Conductor, 24 AWG Jacketed Teflon Cable. The sensors in this series are manufactured using ACI's proven encapsulation process to eliminate the effects of moisture upon the sensors. The probe is designed to be used in a Refrigerated, Freezer or Hydronic applications where a remote sensor must be used. An optional NEMA 4X rated weatherproof enclosure and NIST Certificate is available as referenced in the ordering grid on the back of the product data sheet. Please contact ACI for more information regarding this sensor or to discuss your application in further detail. Other options that may be available upon request.

Applications: Pharmaceutical, Refrigerators, Freezers, Hydronic Heating, Remote Sensor Applications

The ACI Thermistor Freezer Series is covered by ACI's Five (5) Year Limited Warranty. The warranty can be found in the front of ACI's Sensors & Transmitters catalog, as well as on ACI's website, www.workaci.com.

PRODUCT SPECIFICATIONS

Sensor Type Sensor Curve	Thermistor Non-Linear, NTC (Negative Temperature Coefficient)
Number Sensing Points:	One
Number Wires:	Three Conductors (White and Two Red Wires); Polarity Sensitive (Tie Red wires together)
Sensor Output @ 25°C (77°F)	A/1.8K: 1.8KΩ nominal A/CP (Type II): 10KΩ nominal A/20K: 20KΩ nominal A/3K: 3KΩ nominal A/AN (Type III): 10KΩ nominal A/CSI: 10KΩ nominal
Accuracy 0-70°C (32-158°F):	+/-0.2°C (+/-0.36°F) except A/CP Series & A/AN Series: +/- 0.85°C (+/-1.53°F); A/1.8K Series: +/- 0.5°C @ 25°C (77°F) and +/-1.0°C (+/-1.8°F)
Stability:	Sensor Dependent; Contact ACI for more information on specific sensor
Response Time (63% Step Change):	15 Seconds nominal
Power Dissipation Constant:	3 mW/°C except A/1.8K Series: 1 mW/°C A/CP-Series & A/AN Series: 2 mW/°C
Sensor Operating Temperature Range:	-40 to 150°C (-40 to 302°F)
Enclosure Operating Temperature Range:	-40 to 70°C (-40 to 158°F)
Storage Temperature Range:	-40 to 80°C (-40 to 176°F)
Operating Humidity Range:	10 to 95% RH, non-condensing
Sensor Pressure Test:	20 PSI (1.38 Bars) maximum
Enclosure Material Flammability Rating:	Polystyrene UL94-V2
Enclosure Ratings:	NEMA 4X (IP 66)
Cable Gland (Fitting) Size Hole Size:	PG7 15 mm (0.591")
Cable Gland Material Sleeve Material:	Polyamide 6 Neoprene
Cable Gland Wire Clamping Size IP Rating:	0.098" (2.5 mm) to 0.256" (6.5 mm) IP 68 (NEMA 6P)
Cable Gland Torque Rating:	2.5 Nm (22.127 lb. inch)
Probe Material:	316 Stainless Steel
Probe Length Probe Diameter:	2" (50.8 mm) 0.1875" (4.76 mm)
Lead Length Cable Diameter:	30' (9.15 m) 0.106" nominal (2.69 mm)
Conductor Size Conductor Material:	24 AWG (0.51 mm) Silver Plated Copper
Lead Wire Insulation Jacket Color:	FEP/FEP (Teflon) Jacketed Cable White
Product Weight:	A/xxK-FRZ2"-30': 0.36 lbs. (0.163 kg) A/xxK-FRZ2"-4X-30': 0.60 lbs. (0.272 kg)
Agency Approvals:	WEEE, RoHS2





DIMENSIONAL DRAWING

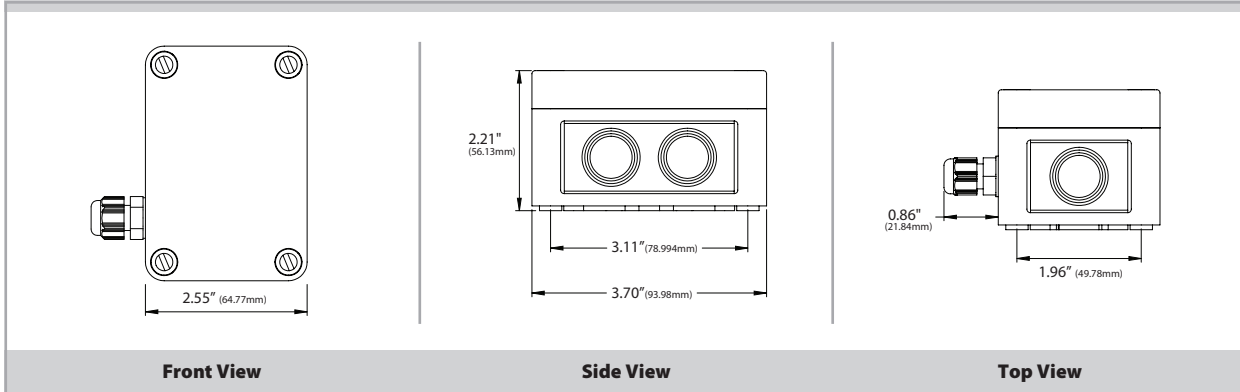

STANDARD ORDERING

Model # Example: **A/1.8K-FRZ2"-30'** -OR- **125164**

Model #	Item #	Description
A/1.8K-FRZ2"-30'	125164	1.8K Freezer Sensor, 30' Leads, 2" Probe
A/3K-FRZ2"-30'	125508	3K Freezer Sensor, 30' Leads, 2" Probe
A/AN-FRZ2"-30'	121305	AN Freezer Sensor, 30' Leads, 2" Probe
A/CP-FRZ2"-30'	125285	CP Freezer Sensor, 30' Leads, 2" Probe
A/CSI-FRZ2"-30'	125290	CSI Freezer Sensor, 30' Leads, 2" Probe
A/20K-FRZ2"-30'	125507	20K Freezer Sensor, 30' Leads, 2" Probe
A/1.8K-FRZ2"-4X-30'	131548	1.8K Freezer Sensor, 30' Leads, 2" Probe, 4X Enclosure
A/3K-FRZ2"-4X-30'	142425	3K Freezer Sensor, 30' Leads, 2" Probe, 4X Enclosure
A/AN-FRZ2"-4X-30'	134410	AN Freezer Sensor, 30' Leads, 2" Probe, 4X Enclosure
A/CP-FRZ2"-4X-30'	125094	CP Freezer Sensor, 30' Leads, 2" Probe, 4X Enclosure
A/CSI-FRZ2"-4X-30'	142426	CSI Freezer Sensor, 30' Leads, 2" Probe, 4X Enclosure
A/20K-FRZ2"-4X-30'	126247	20K Freezer Sensor, 30' Leads, 2" Probe, 4X Enclosure

OPTIONAL SENSOR ORDERING

Model # Example: **A/ 1.8K FRZ2" 4X 30' NIST**

		MODEL #
A. Sensor Series No Selection Required	A/ _____ →	A/
B. Model Series Select One (1)	1.8K 3K AN CP CSI 20K	
C. Configuration No Selection Required	FRZ2" = Freezer Sensor _____ →	FRZ2"
D. Enclosure Select One (1)	---- = No Enclosure 4X = NEMA 4X Weather Proof Plastic Enclosure	
E. Lead Length No Selection Required	30' = 30 Feet (9.15m) _____ →	30'
F. NIST Select One (1)	---- = No NIST Certificate NIST = NIST Certificate (Must Specify 1, 3 or 5 Points)	

