



# THERMOWELLS

## Machined Wells

ACI's Machined Thermowells are used with temperature instruments in process systems where gas or liquid medias are used to provide a degree of protection for the sensing element when installed inside of a pipe, tank, or piece of equipment. The thermowell provides easy access for NIST Certified applications and enables users to easily replace the sensor without having to drain the entire system. Thermowells also protect the small diameter sensing probes from stresses created by high temperatures and pressures, corrosive environments, or the flow of gas or liquid medias through pipes or equipment. It is recommended to follow a Wake Frequency calculator using the ASME PTC 19.3 TW-2016 standard to help prevent vibrational

destruction from damaging the thermowell. ACI's standard thermowells are made of 304 stainless steel which ensures long lasting reliability and corrosion resistance. Optional 316 Stainless Steel is available for use in applications where higher corrosion resistance is required. This series is machined from solid bar stock to precision tolerances which provides maximum heat transfer when used with a corresponding ACI sensor. When necessary, thermal grease is available from ACI to improve the sensor's response time. Insertion depth should be long enough to permit the entire temperature-sensitive section of the temperature probe to project into the medium being monitored, thus maximizing measurement accuracy.

**Applications:** Chilled and Hot Water Systems, Hydronic Heating Systems, Boilers, Pumps, Compressors, Chillers, Refrigeration Systems, Tanks, Aquariums, Process Control Systems, Compressed Air and Gas lines

**All ACI Thermowells are covered by ACI's Five Year Limited Warranty. The warranty can be found in the front of ACI's Sensors & Transmitters catalog, as well as on ACI's website.**

### PRODUCT SPECIFICATIONS

<b>Thermowell Hex Size:</b>	1.125" (28.57 mm)
<b>Insertion Length:</b>	See Ordering Grid (Tolerance: +/- 0.050" (+/- 1.27 mm))
<b>Thermowell Bore Diameter:</b>	0.260" +/- 0.003" (6.60 mm +/- 0.0762 mm)
<b>Shank Type:</b>	Stepped and Straight (See Ordering Grid)
<b>Shank Dimensions:</b>	Straight: Root Diameter: 0.500" (12.7 mm); Tip Diameter: 0.500" (12.7 mm)
<b>+/- 0.010" (+/- 0.254 mm)</b>	Stepped: Root Diameter: 0.630" (16.002 mm); Tip Diameter: 0.500" (12.7 mm)
<b>Stepped Thermowell Reduced Tip Length:</b>	2.500" (63.5 mm)
<b>Tip Thickness:</b>	0.250" (6.35 mm)
<b>Internal "Instrument" Thread:</b>	1/2" NPS
<b>External "Process" Thread:</b>	1/2" MNPT - 14
<b>Material Type:</b>	304 and 316 Series Stainless Steel Available (See Ordering Grid)
<b>Surface Finish:</b>	Polished to 16 RMS

### MAXIMUM PRESSURE VS TEMPERATURE RATINGS [304 STAINLESS STEEL]

<b>Temperature:</b>	70°F (21.1°C)	200°F (93.2°C)	400°F (204.2°C)	600°F (315.2°C)	800°F (426.2°C)	1000°F (537.2°C)	1200°F (648.2°C)
<b>PSIG (Bar):</b>	7000 (482.6)	6000 (413.7)	5600 (386.1)	5400 (372.3)	5200 (358.5)	4500 (310.3)	1650 (110.3)

### MAXIMUM PRESSURE VS TEMPERATURE RATINGS [316 STAINLESS STEEL]

<b>Temperature:</b>	70°F (21.1°C)	200°F (93.2°C)	400°F (204.2°C)	600°F (315.2°C)	800°F (426.2°C)	1000°F (537.2°C)	1200°F (648.2°C)
<b>PSIG (Bar):</b>	7000 (482.6)	7000 (482.6)	6400 (441.2)	6200 (427.4)	6100 (420.5)	5100 (351.6)	2500 (172.3)

**Note:** All machined thermowells and the materials of construction, media/corrosion resistance, flow rating, temperature and pressures are the sole responsibility of the systems engineer that incorporates the thermowell into their design.



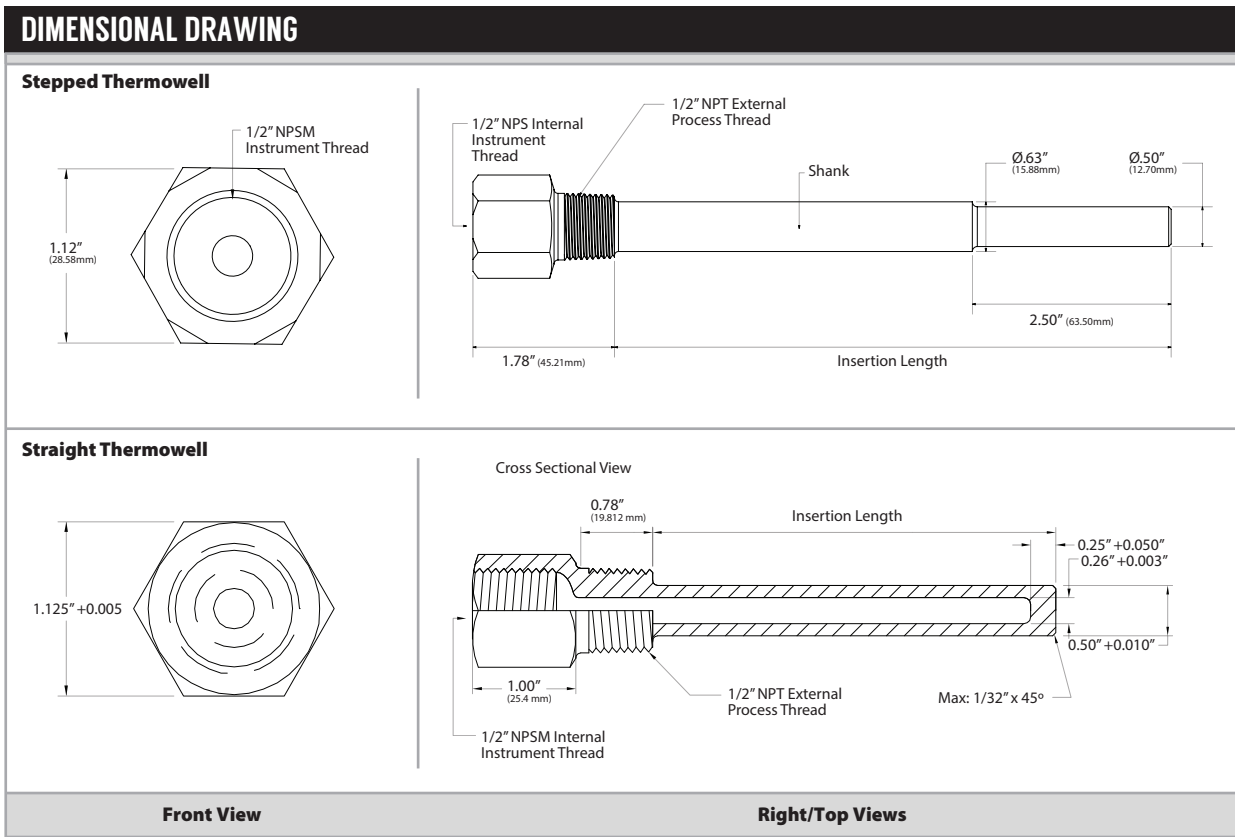

### STANDARD ORDERING

Model # Example: **A/M24"** -OR- **128342**

Model #	Item #	Insertion Length	Material Type	Shank Type	Internal Thread	External Thread	Shipping Weight
<b>A/M1"</b>	128337	1.25" (31.7 mm)	304 SS	Straight	1/2" NPS Thread	1/2" NPT Thread	0.19 lbs (0.08kg)
<b>A/M2.5"</b>	128338	2.5" (63.5 mm)	304 SS	Straight	1/2" NPS Thread	1/2" NPT Thread	0.39 lbs (0.18kg)
<b>A/M4"</b>	128343	4.0" (101.6 mm)	304 SS	Stepped	1/2" NPS Thread	1/2" NPT Thread	0.52 lbs (0.24kg)
<b>A/M6"</b>	128344	6.25" (158.7 mm)	304 SS	Stepped	1/2" NPS Thread	1/2" NPT Thread	0.68 lbs (0.31kg)
<b>A/M8"</b>	138725	8.0" (203.2 mm)	304 SS	Straight	1/2" NPS Thread	1/2" NPT Thread	0.89 lbs (0.40kg)
<b>A/M12"</b>	128339	12.0" (304.8 mm)	304 SS	Stepped	1/2" NPS Thread	1/2" NPT Thread	1.11 lbs (0.50kg)
<b>A/M18"</b>	128341	18.0" (457.2 mm)	304 SS	Stepped	1/2" NPS Thread	1/2" NPT Thread	1.57 lbs (0.71kg)
<b>A/M24"</b>	128342	24.0" (609.6 mm)	304 SS	Stepped	1/2" NPS Thread	1/2" NPT Thread	2.05 lbs (0.93kg)
<b>A/M2.5"-316SS</b>	128352	2.5" (63.5 mm)	316 SS	Straight	1/2" NPS Thread	1/2" NPT Thread	0.39 lbs (0.18kg)
<b>A/M4"-316SS</b>	128353	4.0" (101.6 mm)	316 SS	Stepped	1/2" NPS Thread	1/2" NPT Thread	0.52 lbs (0.24kg)
<b>A/M6"-316SS</b>	128354	6.0" (152.4 mm)	316 SS	Stepped	1/2" NPS Thread	1/2" NPT Thread	0.68 lbs (0.31kg)

### ACCESSORIES ORDERING

Model # Example: **A/3/4" TO 1/2" REDUCER** -OR- **138479**

Model #	Item #	Description
<b>SG</b>	102951	-40-400°F Silicone Grease, 5.0 oz
<b>NSG HEAT TRANSFER PASTE 2 OZ</b>	102595	-40-392°F Non-Silicone Grease, 2.0 oz
<b>A/3/4" TO 1/2" REDUCER</b>	138479	3/4" to 1/2" Reducer Steel, 3/4" MNPT to 1/2" FNPT
<b>A/1/8" TO 1/4" ADAPTER</b>	138480	1/8" to 1/4" Adapter Steel, 1/8" FNPT to 1/4" MNPT
<b>A/1/2" TO 1/4" REDUCER</b>	138478	1/2" to 1/4" Reducer Brass, 1/2" FNPT to 1/4" MNPT

