



# FIXED "STATUS" SWITCHES

## CS2, CSX2, SCS2 & SCSX2 Series



The ACI Fixed "Status" Current switches are designed for use in any AC current monitoring application in which you are looking for a "Go/No Go" or On/Off status for a particular piece of equipment. The current switches should be installed on the line side of the power to the motor, pump, compressor or other equipment. The current switches are available in both solid and split-core versions which also includes a Patented 35 mm Din Rail mounting foot for easy installation in panel mount applications. The solid-core versions are a great choice for new installations or OEM applications in which cost sensitivity, lower trip points and environmental issues may be of concern. The split-core version of the current switches work great in retrofit applications and for use in service vehicles since one part will work in most applications and can be installed without disconnecting any wires. The fixed current status switches can also be used

to determine the run time of your equipment and basic load trending applications where you want to know when your piece of equipment runs and for how long it runs for when logging the contact closures on your building management system or PLC.

**Applications:** Pump Status, Fan Status, Compressors, Motor Status, Ovens, Industrial Equipment, Lighting Status and Usage, Electrical Load Status, Local Alarms (Strobes and Audible Alarms)

**The Fixed Current Switches are covered by ACI's Five (5) Year Limited Warranty. The warranty can be found in the front of ACI's Sensors & Transmitters catalog, as well as on ACI's website, [www.workaci.com](http://www.workaci.com).**

### PRODUCT SPECIFICATIONS

<b>Monitored Current Type:</b>	AC Current
<b>Maximum AC Voltage:</b>	600 VAC
<b>Operating Frequency Range:</b>	40 to 1 kHz
<b>Core Style:</b>	Solid-Core and Split-Core Versions available (See Ordering Grid)
<b>Sensor Power:</b>	Induced from the Monitored Conductor
<b>Amperage Range:</b>	See Ordering Grid
<b>Isolation Voltage:</b>	2200 VAC
<b>Trip Point Style   Trip Point:</b>	Fixed Trip Point   See Ordering Grid
<b>Contact Type:</b>	Normally-Open "N/O" or Normally-Closed "N/C" (See ordering Grid)
<b>"Status" Contact Rating:</b>	0.2A @ 200 VAC/VDC
<b>"Status" Contact "On" Resistance   "Off" Resistance:</b>	< 10 Ohms (tripped)   > 1 Meg Ohms (Open)
<b>Response Time:</b>	See Response Time Table on back of data sheet
<b>Status LED Indication 1:</b>	Red LED (Monitored current is above Trip Point)
<b>Aperture Size:</b>	0.75" (19.05 mm)
<b>Din Rail Size:</b>	35 mm   (U.S. Patent No. 7,416,421)
<b>Operating Temperature Range:</b>	5 to 104°F (-15 to 40°C)
<b>Operating Humidity Range:</b>	0 to 95%, non-condensing
<b>Recommended Storage Temperature   RH Range:</b>	41 to 95°F (5 to 35°C)   40% to 85% RH, non-condensing
<b>Enclosure Material   Flammability Rating:</b>	PC/ABS (Polycarbonate/ABS Blend)   UL94-V0
<b>Wiring Connections:</b>	2 Position Screw Terminal Block (Not Polarity Sensitive)
<b>Wire Size:</b>	16 to 22 AWG (1.31 mm <sup>2</sup> to 0.33 mm <sup>2</sup> ) Copper Wires only
<b>Terminal Block Torque Rating:</b>	4.43 to 5.31 in-lbs. (0.5 to 0.6 Nm)
<b>Minimum Mounting Distance:</b>	1" (2.6 cm) between current switch (Relays, Contactors, Transformers)
<b>Agency Approvals:</b>	UL/CUL US Listed (UL 508) Ind. Control Equipment (File # E309723), CE, RoHS2, WEEE
<b>Product Weight:</b>	<b>A/CS2 and A/CSX2:</b> 0.216 lbs. (0.099kg)   <b>A/SCS2 and A/SCSX2:</b> 0.270 lbs. (0.123 kg) <b>A/SCS2-L:</b> 0.280 lbs. (0.127 kg)
<b>Product Dimensions (L x W x H):</b>	<b>Solid Core Versions:</b> 2.760" (70.11 mm) x 3.343" (84.92 mm) x 1.050" (26.67 mm) <b>Split Core Versions:</b> 2.780" (70.51 mm) x 3.238" (82.25 mm) x 1.120" (28.45 mm)

**Note<sup>1</sup>:** The LED should not be used to determine if current is present. At low currents the LED may not be visible



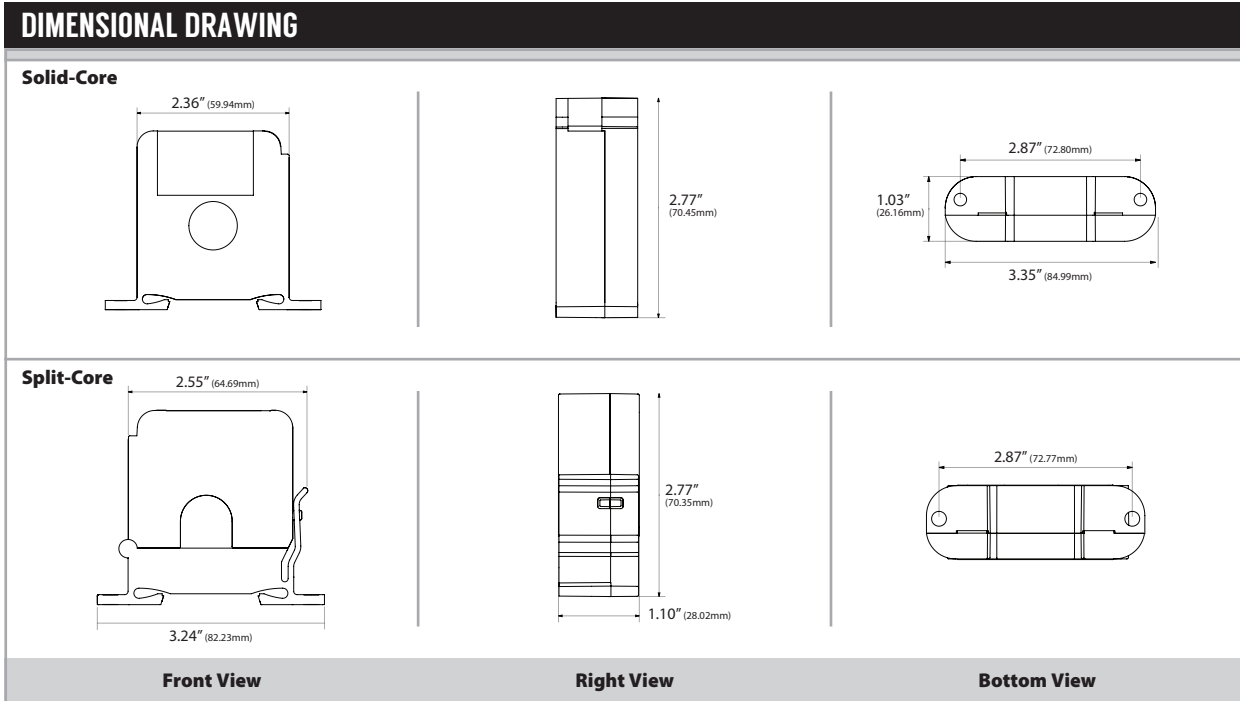

### RESPONSE TIME

Green Boxes: response time at specified current above trip point | Red Boxes: response time below specified trip point where sensors may trip

Model #	0.15 Amps	0.20 Amps	0.25 Amps	0.50 Amps	0.75 Amps	1.0 Amp	1.20 Amps	1.50 Amps	10 Amps	20 Amps
A/CS2	156mS	100mS	84mS	----	----	32mS	----	----	26mS	24mS
A/CSX2	----	189mS	134mS	----	----	48mS	----	----	42mS	41mS
A/SCS2	----	----	----	484mS	----	72mS	----	45mS	26mS	20mS
A/SCSX-2	----	----	----	----	----	194mS	102mS	102mS	42mS	42mS
A/SCS2-L	----	224mS	144mS	65mS	47mS	39mS	----	----	25mS	22mS

Note: ---- = unit was not tested (below minimum trip point or for that range)

### STANDARD ORDERING

Model # Example: A/SCSX2 -OR- 142357

Model #	Item #	Trip Point Type	N/O	N/C	Solid-Core	Split-Core	Amp Range	Trip Point	Contact Rating
A/CS2	142340	Fixed Trip Point	•		•		0 to 250A	0.25A or less	0.2A @ 200 VAC/VDC
A/CSX2	142359	Fixed Trip Point		•	•		0 to 250A	0.25A or less	0.2A @ 200 VAC/VDC
A/SCS2	142358	Fixed Trip Point	•			•	0 to 200A	1.5A or less	0.2A @ 200 VAC/VDC
A/SCS2-L	142356	Fixed Trip Point	•			•	0 to 200A	0.5A or less	0.2A @ 200 VAC/VDC
A/SCSX2	142357	Fixed Trip Point		•		•	0 to 200A	1.5A or less	0.2A @ 200 VAC/VDC

The Fixed Current Switches are not intended to be used in Life / Safety Applications or in Hazardous / Classified Locations

Revision C0000001 | Rev 1.0

