

Features & Options

- Power and Communication on Just Two Wires
- Available with Temperature Setpoint and Optional Override, Display and %RH Sensing
- Thermistor, Voltage, Resistance or Dry Contact Outputs
- Up to 500 Foot Wire Runs — Perfect for Existing Wires

Many existing buildings have two wire sensors that lack the features people expect in today's sophisticated systems. The BAPI-Com uses those existing two wires and offers the owner a full function sensor with temperature setpoint, occupant override, an optional easy-to-read display and optional %RH sensing.

This retrofit sensor can update old systems to a new look without pulling new wire or disrupting the occupants while saving on labor.

The sensors are powered and communicate over two wires to a Communication Output Module for use by a BAS system. The outputs are configurable as a thermistor, voltage, resistance or dry contact override output. The sensor is powered by the Communication Output Module which itself is supplied by any 24VDC/VAC source.



BAPI-Com Room Units with White and Gray Logo Plates



Comm. Output Module (each unit includes a room sensor & comm module)

Specifications

ROOM SENSOR SPECS

Power: 18VDC, from the Comm. Output Module

Wiring: 2 wires, Up to 500ft (new or existing)

AWG gauge 22 to 14AWG

Shielding..... Preferred (not required)

Temp Sensor: Thermistor, $\pm 0.36^{\circ}\text{F}$ ($\pm 0.2^{\circ}\text{C}$)

RH/Temp Sensor Construction:

Communicating Integrated Circuit

Humidity: Capacitive Polymer, $\pm 2\%$ RH

(10 to 90%) @25°C, Fully Compensated

Temp: Semi-conductor Band Gap, $\pm 0.3^{\circ}\text{C}$ @ 25°C

Pole Rate: 400 ms

Ambient:

32 to 122°F (0 to 50°C),

0 to 95%RH, non-condensing

COMMUNICATION OUTPUT MODULE SPECS

Power in: 24VDC/AC, 30mA

Terminations:

Comm. & PWR 2 wires to the sensor

Power in..... 2 wires, 12 to 28 AWG

Output..... 2 wires per output, 12 to 28 AWG

Override Input..... 2 wires, 16 to 30 AWG

Outputs:

Volts..... 0 to 5 or 0 to 10VDC, 10kΩ min

Resistance..... 400Ω to 20KΩ span

Thermistor 10K-2 or 10K-3

Input (DI): Ext. Override Dry Contact,
Closed = Occupied

EZ Mounting: DIN Rail, Snaptrack or surface

Material:..... ABS Plastic, UL94V-0, RoHS

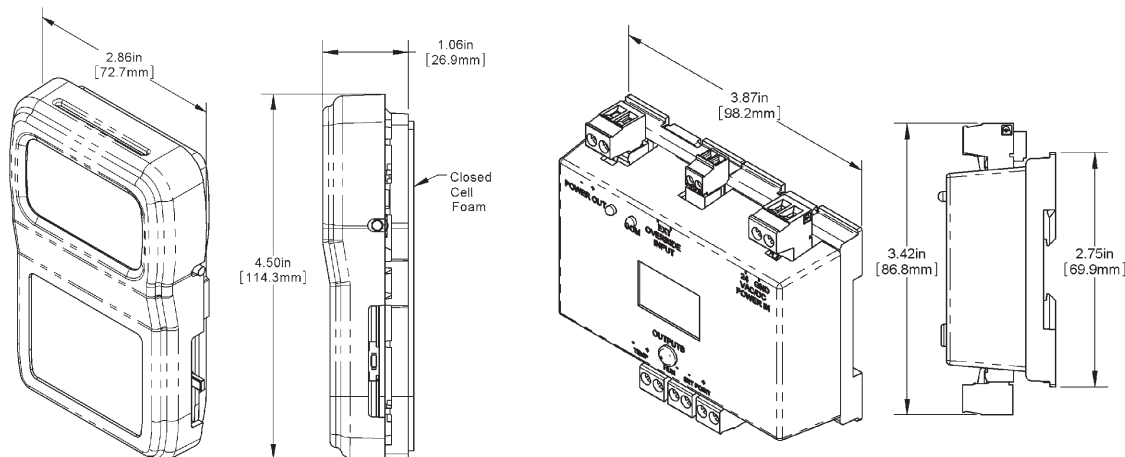

BAPI-Com, Two-wire Multifunction Sensor

A27

Rev. 03/21/14

Temperature Sensors



Ordering Information		BAPI-Com Room Temperature Sensor Unit							
BA/BS4MCOM	BAPI-Stat 4 Enclosure Sensor with Pushbuttons for Setpoint & Override & the Communication Output Module. (Must use display -F or -C)								
BA/BS4SCOM	BAPI-Stat 4 Enclosure Sensor with Slide Setpoint & the Communication Output Module. (Override button on the side if needed)								
Display Option (Required Selection Field, Select Only One)									
-F	Display Configurable in the field (default is in °F), (Optional Legend selection below)								
-C	Display Configurable in the field (default is in °C), (Optional Legend selection below)								
-X	No Display Option (Must use a Slide for the Setpoint), (Required Legend selection below)								
Humidity Sensing (Skip if not required)									
-2	2% Humidity Sensor								
Temperature Output Range (Also used for the voltage output module range) (Required)									
#	Temperature Output	Designator	Temperature Output	Designator					
	50 to 90°F or 10 to 32°C	C	65 to 80°F or 18 to 27°C	F					
	55 to 85°F or 13 to 30°C	D	70 to 74°F or 21 to 23°C	L					
	60 to 80°F or 15 to 27°C	E	See Application Notes, pg 13 for more ranges						
Setpoint Configuration (Required for units with Display) (Skip for units without Display)									
#	Setpoint Display	Designator	Setpoint Display	Designator					
	-2 to +2	P	65 to 80°F or 18 to 27°C	F					
	-3 to +3	A	70 to 74°F or 21 to 23°C	L					
	-5 to +5	B	0 to 100% RH	M					
	50 to 90°F or 10 to 32°C	C	35 to 70% RH	N					
	55 to 85°F or 13 to 30°C	D	0 to 100°F or -18 to 38°C	GG					
	60 to 80°F or 15 to 27°C	E	See Application Notes, pg 13 for more ranges						
Legend Designator on the Sensor Cover (Required for all slide type sensors)									
-L0	No Legend								
-L6	COOL/WARM								
Logo Plate Color (Required)									
-WMW	Warm White Logo Plate Color								
-GRY	Gray Logo Plate Color								
Special Factory Configurations — List in Alpha order as needed (-ES-SDO) (Skip if not required)									
-ES	External Temp Sensor (Requires separately purchased 10K-2 sensor), (Not available with humidity)								
-SDO	Setpoint Display Only								
Setpoint Output Value Range (Skip if not required)									
#	Desired Range	Designator	Desired Range	Designator					
	0 to 20KΩ	80	10K to 30KΩ	84					
	4.75K to 24.75KΩ	81	0 to 5V*	00					
	6.19K to 26.19KΩ	82	0 to 10V*	10					
	7.87K to 27.87KΩ	83	See App. Notes, pg 12 for more ranges						
Override Output — Momentary for 3-5 seconds (Required)									
-J	Dry Contact Override on dedicated terminals (Not Available for Humidity Units)								
-M	Override in Parallel (//) with RH signal								
-N	Override in Parallel (//) with Sensor								
-P	Override in Parallel (//) with Setpoint								
-Z	No Override								
Room Humidity Output Value (Skip if humidity is not required)									
-M00	Humidity Output 0-5V = 0-100%RH (Common ground only)								
-M10	Humidity Output 0-10V = 0-100%RH (Common ground only)								
Room Temperature Output Value (Skip if not required)									
-102	Thermistor Temperature Output, 10K-2, 10KΩ @ 25°C								
-103	Thermistor Temperature Output, 10K-3, 10KΩ @ 25°C								
-10311	Thermistor Temp Output, 10K-3 w/ 11KΩ shunt, 5238Ω @ 25°C								
-00	0 to 5V over the Temp Output Range (Common grnd only)								
-10	0 to 10V over the Temp Output Range (Common grnd only)								
Connection Configuration (Required)									
-CG	Common ground for resistive and voltage outputs								
-DF	Differential ground for resistive outputs								
EXAMPLE									
BA/BS4SCOM	-F	-C	-P	-L6	-WMW	-82	-N	-103	-DF
BA/BS4SCOM-F-C-P-L6-WMW-82-N-103-DF - BS4 sensor, w/slide setpoint & override, Outputs for sensor, setpoint and override									
Your Part Number:									

*Common Ground Only

Call BAPI if you have questions about the above ordering grid or the configuration of the product you are ordering.

