

Room sensor CO₂ / Humidity / Temperature

Active room temperature, humidity and CO₂ sensor with incorporated NFC technology. This sensor incorporates self-calibrating dual channel CO₂ technology which can be used for all applications even when occupied 24/7. Selectable outputs include 0...5V, 0...10V, 2...10V and MP-Bus. NFC capabilities allow for easier setup, commissioning and troubleshooting.

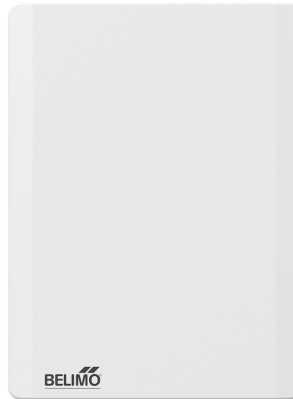

5-year warranty



Type Overview

Type	Communication	Output signal active CO ₂	Output signal active humidity	Output signal active temperature
22RTM-59-1	MP-Bus	0...5 V, 0...10 V, 2...10 V	0...5 V, 0...10 V, 2...10 V	0...5 V, 0...10 V, 2...10 V

Technical Data

Electrical Data	Nominal voltage	AC/DC 24 V
	Nominal voltage range	AC 19.2...28.8 V / DC 19.2...28.8 V
	Power consumption AC	1 VA
	Power consumption DC	0.5 W
	Cable entry	Wire openings at the backside (for In-wall wiring) and top-/bottom side (for On-wall wiring)
Functional Data	Sensor Technology	CO ₂ : NDIR (non dispersive infrared) dual channel
	Application	air
	Communicative control	MP-Bus
	Voltage output	3x 0...5 V, 0...10 V, 2...10 V, min. load 10 kΩ
	Voltage output note	min. load 10 kΩ
	Output signal active note	Output 0...5 V, 0...10 V (factory setting), 2...10 V selectable via NFC
Measuring Data	Measuring values	CO ₂ relative humidity Dew point Temperature
	Measuring range CO ₂	0...2000 ppm
	Measuring range humidity	0...100% r.H.
	Measuring range temperature	30...120°F [0...50°C]
	Accuracy CO ₂	±(50 ppm + 2% of measured value)
	Accuracy humidity	Typical ±3% between 20...80% RH @ 77°F [25°C]
	Accuracy temperature active	±0.9°F @ 77°F [±0.5°C @ 25°C]
	Long-term stability	±20 ppm p.a. ±0.25% RH p.a. @ 77°F @ 50% RH
	Time constant τ (63%) in the room	Typical 960 s
	Wall Coupling Factor	52 %
Materials	Housing	White, RAL 9003

Safety Data	Ambient humidity	max. 95% r.H., non-condensing
	Ambient temperature	30...120°F [0...50°C]
	Storage temperature	-5...140°F [-20...60°C]
	Protection class IEC/EN	III Protective extra-low voltage (PELV)
	EU Conformity	CE Marking
	Certification IEC/EN	IEC/EN 60730-1 and IEC/EN 60730-2-9
	Degree of protection IEC/EN	IP30
	Degree of protection NEMA/UL	NEMA 1
	Quality Standard	ISO 9001

Safety Notes

This device has been designed for use in stationary heating, ventilation and air-conditioning systems and must not be used outside the specified field of application. Unauthorized modifications are prohibited. The product must not be used in relation with any equipment that in case of a failure may threaten humans, animals or assets.

Ensure all power is disconnected before installing. Do not connect to live/operating equipment.

Only authorized specialists may carry out installation. All applicable legal or institutional installation regulations must be complied during installation.

The device contains electrical and electronic components and must not be disposed of as household refuse. All locally valid regulations and requirements must be observed.

Remarks
General Remarks Concerning Sensors

The measuring result is influenced by the thermal characteristics of the wall. A solid concrete wall responds to thermal fluctuations within a room slower than a light-weight structure wall. Room temperature sensors installed in flush-mounted boxes have a longer response time to thermal variations. For example, in extreme cases they will detect the radiant heat of the wall even if the air temperature in the room is lower. The quicker the dynamics of the wall (temperature acceptance of the wall) or the longer the selected inquiry interval of the temperature sensor is, the smaller the deviations are.

Build-up of Self-Heating by Electrical Dissipative Power

Temperature sensors with electronic components always have a dissipative power which affects the temperature measurement of the ambient air. The dissipation in active temperature sensors shows a linear increase with rising operating voltage. The dissipative power should be taken into account when measuring temperature. In case of a fixed operating voltage (± 0.2 V) this is normally done by adding or reducing a constant offset value. As Belimo transducers work with a variable operating voltage, only one operating voltage can be taken into consideration, for reasons of production engineering. Transducers 0...10 V / 4...20 mA have a standard setting at an operating voltage of DC 24 V. That means, that at this voltage, the expected measuring error of the output signal will be the least. For other operating voltages, the offset error will be increased by a changing power loss of the sensor electronics.

If a readjustment directly at the active sensor should be necessary during later operation, this can be done with the following adjustment methods.

- For sensors with NFC or dongle by the corresponding Belimo app
- For sensors with a trimming potentiometer on the sensor board
- For bus sensors via bus interface with a corresponding software variable

Application notice for humidity sensors

Refrain from touching the sensitive humidity sensor element. Touching the sensitive surface will void warranty.

For standard environmental conditions the manufacturing accuracy specified in the datasheet will be warranted for two years. When exposed to harsh environmental conditions such as high ambient temperature and/or high levels of humidity, or presence of aggressive gases (i.e. chlorine, ozone, ammonia) the sensor element may be affected and readings may be outside specified accuracy. Replacement of deteriorated humidity sensors due to harsh environmental conditions are not subject of the general warranty.

The sensor shows best performance when operated within recommended normal temperature range of 5...60°C and humidity range of 20...80% r.H. Long-term exposure to conditions outside normal range, especially at high humidity, may temporarily offset the humidity signal (e.g. +3% r.H. after 60h kept at >80% r.H.). After returning into the normal temperature and humidity range the sensor will slowly come back to calibration state by itself.

Information Self-Calibration Feature CO₂

All CO₂ sensors are subject to drift caused by the aging process of the components, resulting in regular re-calibration or replacement of units. However, the dual channel technology integrates automatic self-calibration technology vs. common used ABC-Logic sensors. Dual channel self-calibration technology is ideally suited for applications operating 24/7 hours such as those in hospitals or other commercial applications. Manual calibration is not required.

Digital input

Auxiliary Digital Input can be used with third-party sensors and switches (window alarm, occupancy detector, etc.). The input values are monitored and transmitted only through the MP-Bus communication protocol.

Scope of delivery

Screws

Accessories

Service tools	Description	Type
	Belimo Assistant App, Smartphone app for easy commissioning, parametrising and maintenance	Belimo Assistant App
	Converter Bluetooth / NFC	ZIP-BT-NFC

Service
NFC connection

Belimo equipment marked with the NFC logo can be operated and configured with the Belimo Assistant App.

Requirement:

- NFC- or Bluetooth-capable smartphone
- Belimo Assistant App (Google Play & Apple AppStore)

Align NFC-capable smartphone on the sensor so that both NFC antennas are superposed.

Connect Bluetooth-enabled smartphone via the Bluetooth-to-NFC Converter ZIP-BT-NFC to the sensor. Technical data and operation instructions are shown in the ZIP-BT-NFC data sheet.

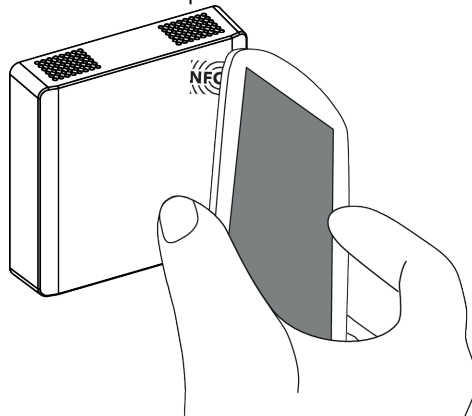
Wiring Diagram

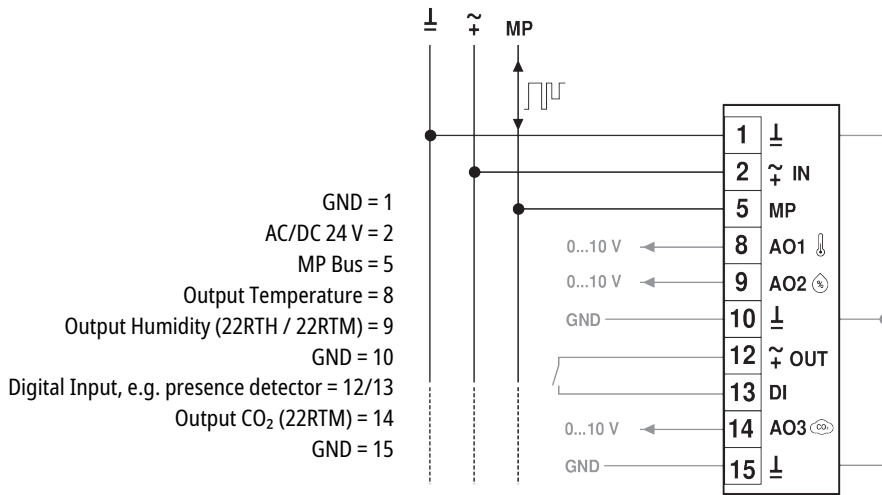

Dimensions

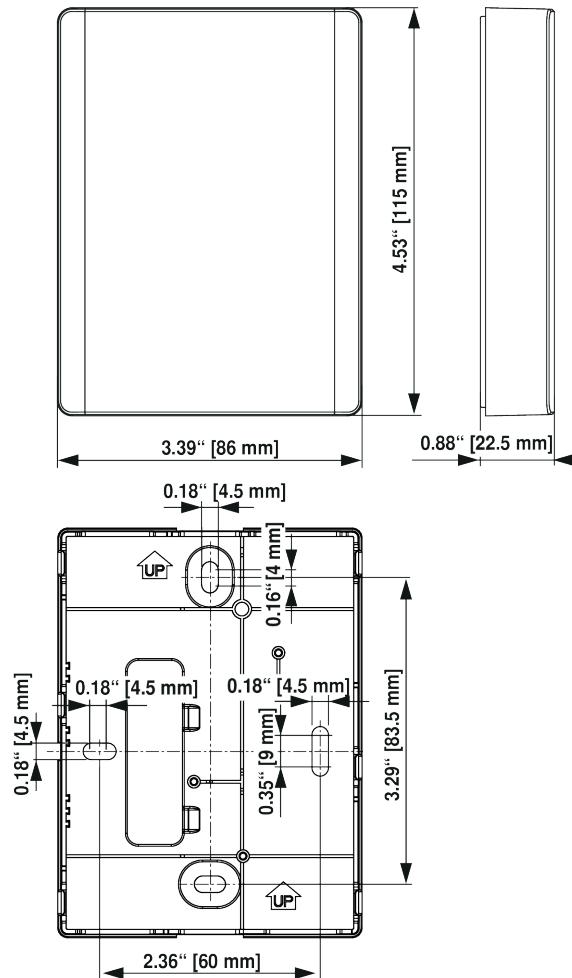

Type	Weight
22RTM-59-1	0.32 lb [0.15 kg]