

B2...VS Series, 2-way, Ball Valve Bronze Body, Stainless Steel Ball and Stem



- Live-load packing set
- Stainless steel ball & stem
- Blow-out proof stem design

Application

This valve is typically used in air handling units on heating or cooling coils, and fan coil unit heating or cooling coils. Some other common applications include Unit Ventilators, VAV Box re-heat coils and bypass loops. This valve is suitable for use in a hydronic system with variable flow.

This valve is designed with MFT functionality which facilitates the use of various control input.

- Up to 35 psi steam
- ½" - 600 PSIG WOG, Cold Non-Shock.
- Federal Specification: WW-V-35C, Type II
Composition: BZ
Style: 3

Technical Data	
Media	chilled or hot water, glycol, 35# steam
Flow characteristic	modified equal percentage
Action	90° rotation valve open CW, valve closed CCW
Sizes	½", ¾", 1", 1¼", 1½", 2"
Type of end fitting	SAE NPT (female connections)
Materials:	
1 Stem packing	reinforced PTFE
2 Stem bearing	reinforced PTFE
3 Ball	316 stainless steel
4 Seat (x2)	reinforced PTFE w/ Durafill
5 Retainer	B16 (¾" - 1") stainless steel B584 (1¼" - 2") stainless steel
6 Gland	B16 brass
7 Stem	316 stainless steel
8 Jam nut	stainless steel
9 Body seal	PTFE (1-1/4" to 2")
10 Body	B584-C84400 bronze

C _v	Valve Nominal Size		Type	Suitable Actuators	
	Inches	DN [mm]	2-way NPT	Spring Return	Non-Spring Return
1	½	15	B2050VS-01	LF Series	LM Series
2	½	15	B2050VS-02		
4	½	15	B2050VS-04		
15	½	15	B2050VS-15	NF	NM
30	¾	20	B219VS		
51	¾	20	B220VS	AF Series	AM Series
43	1	25	B224VS		
68	1	25	B225VS		
48	1¼	32	B232VS		
84	1½	40	B239VS		
177	1½	40	B240VS		
108	2	50	B249VS	GM Series	SY Series

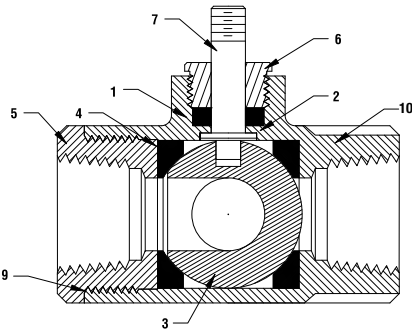

Pressure rating	600 psig WOG
Media temp. range	-22°F to +280°F (-30°C to +138°C)
Close-off pressure	600 psig @ 100°F
Maximum differential pressure (ΔP)	<600 psig

Flow Patterns

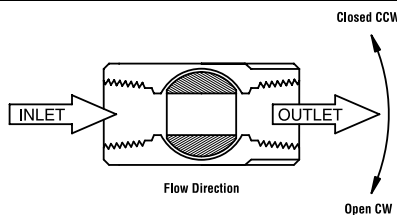

Tech.Doc - 11/14 - Subject to change. © Belimo Aircontrols (USA), Inc.

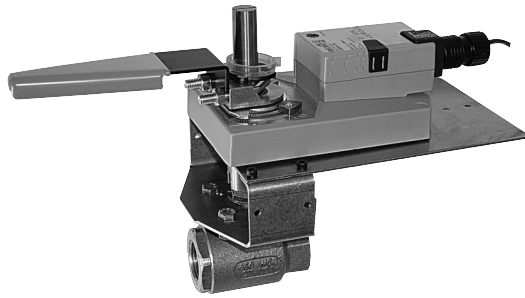

Models

AMX24-MFT-X1
 AMX24-MFT95-X1
 ARX24-MFT

Technical Data	
Power supply	24 VAC ± 20% 50/60 Hz 24 VDC ± 10%
Power consumption	4 W (1.25 W)
Transformer sizing	6 VA (class 2 power source)
Electrical connection	3 ft. [1m], 10 ft. [3m], 16 ft. [5m] 18 GA plenum rated cable ½" conduit connector
Overload protection	electronic throughout 0° to 95° rotation
Input impedance	100 kΩ for 2 to 10 VDC (0.1 mA) 500 Ω for 4 to 20 mA 750 Ω for PWM 1500 Ω for on/off and floating point
Feedback	2 to 10 VDC, 0.5 mA max VDC variable
Angle of rotation	max 95°, adjust. with mechanical stop electronically variable
Torque	180 in-lbs [20 Nm]
Direction of rotation	reversible with switch
Position indication	reflective visual indicator (snap-on)
Manual override	external push button
Running time	150 seconds (default) variable (90 to 350 seconds)
Humidity	5 to 95% RH non-condensing (EN 60730-1)
Ambient temperature	-22°F to +122°F [-30°C to +50°C]
Storage temperature	-40°F to +176°F [-40°C to +80°C]
Housing	NEMA type 2/IP54
Housing material	UL94-5VA
Agency listings	cULus acc. to UL 60730-1/-2-14, CAN/CSA E60730-1, CSA C22.2 No. 24-93, CE acc. to 89/336/EEC
Noise level	<45 db(A)
Servicing	maintenance free
Quality standard	ISO 9001

Dimensions with 2-Way Valve

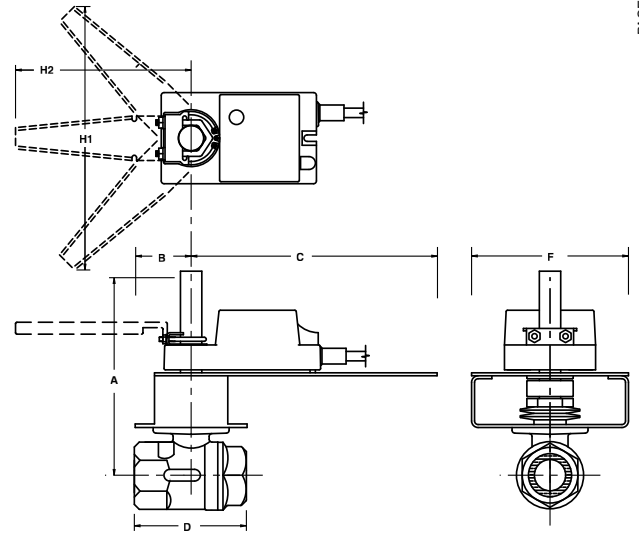

PAGE 7

Valve Nominal Size Dimensions (Inches)

Valve Body	COP	Inches	DN [mm]	A	B	C	D	F	H1	H2
B225VS	200	1	25	7.00	2.00	8.00	3.62	6.25	9.75	8.50
B232VS	600	1¼	32	7.25	2.00	8.00	3.97	6.25	9.75	8.50
B224VSS	1000	1	25	7.00	2.00	8.00	3.37	6.25	9.75	8.50

Dimensions with 3-Way Valve

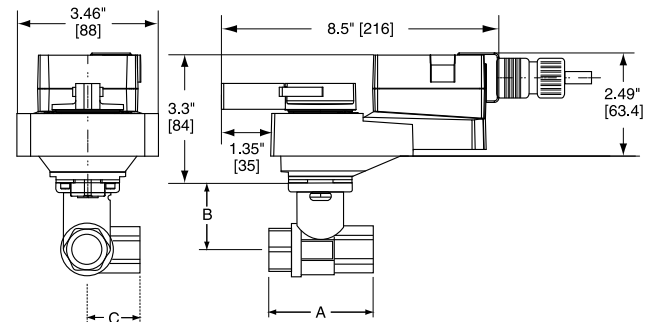

Valve Nominal Size Dimensions (mm)

Valve Body	COP	Inches	DN [mm]	A	B	C
B340L	200	1½	40	4.80" [122]	2.44" [62]	2.61" [65]
B350L	200	2	50	5.60" [142]	2.67" [68]	3.11" [79]

Tech. Doc - 11/14 - Subject to change. © Belimo Aircontrols (USA), Inc.

Wiring Diagrams

- 1 Provide overload protection and disconnect as required.
- 3 Actuators may also be powered by 24 VDC.
- 4 Position feedback cannot be used with Triac sink controller. The actuator internal common reference is not compatible.
- 5 Control signal may be pulsed from either the Hot (source) or the Common (sink) 24 VAC line.
- 6 ZG-R01 may be used.
- 7 Contact closures A & B also can be triacs. A & B should both be closed for triac source and open for triac sink.
- 8 For triac sink the common connection from the actuator must be connected to the hot connection of the controller.

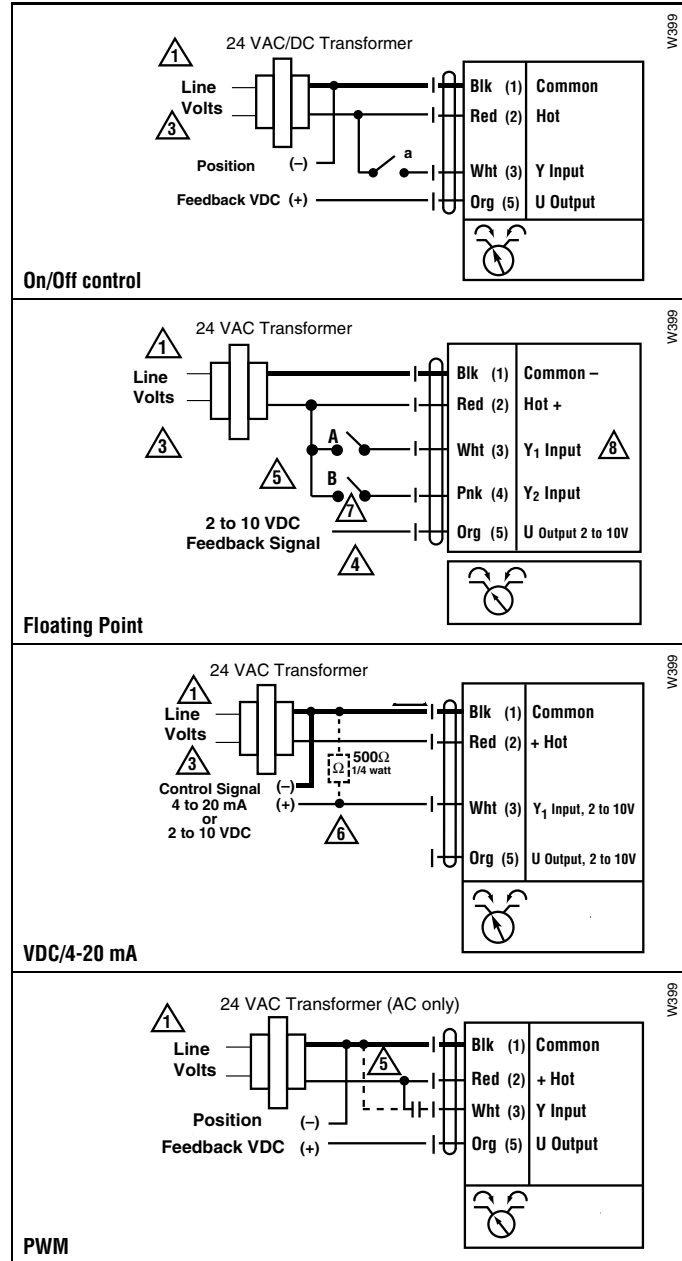



INSTALLATION NOTES

- 21** Provide overload protection and disconnect as required.
- 22** Actuators and controller must have separate transformers.
- 23** Consult controller instruction data for more detailed information.
- 24** Resistor value depends on the type of controller and the number of actuators. No resistor is used for one actuator. Honeywell® resistor kits may also be used.
- 25** To reverse control rotation, use the reversing switch.

Override

Switch A	Switch B	Damper Position
		Damper Open
		Damper Closed

The direction of rotation switch is set so that the fail safe position and the position of the damper is closed with no signal at wire R.

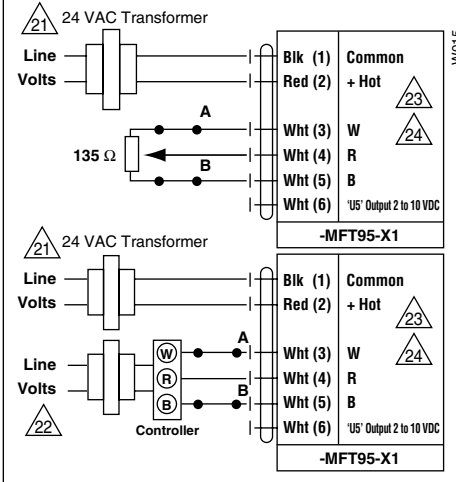

Low Limit Control

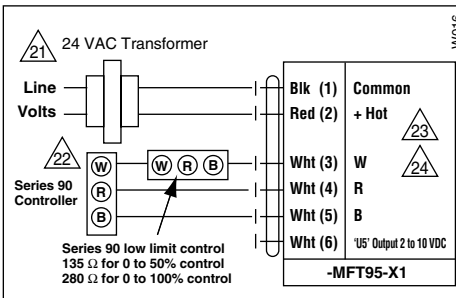

High Limit Control

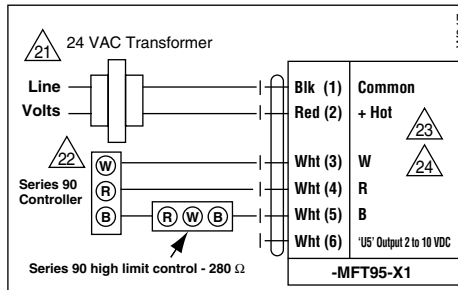

Wiring Multiple Actuators to a Series 90 Controller

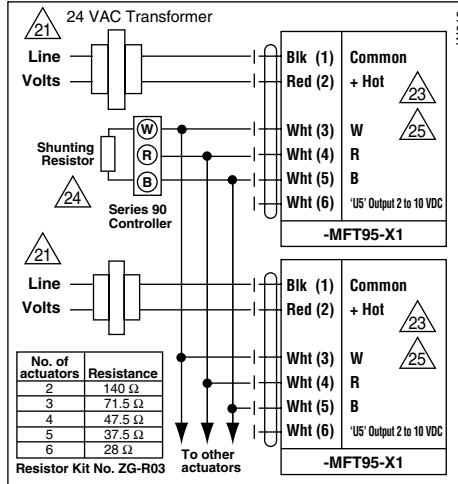

Wiring Multiple Actuators to a Series 90 Controller using a Minimum Position Potentiometer

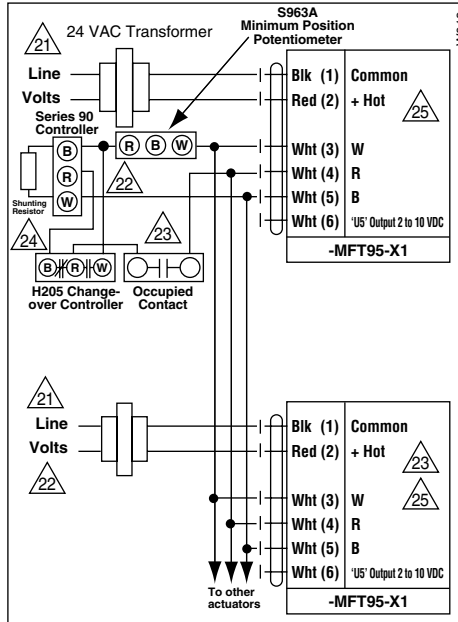

Typical wiring diagrams for multiple actuators used with the W973, W7100 and T775 controllers

