

B6300VB-207, 3", V Ball Control Valve

Carbon Steel Body, Hardened Chrome Plated, Stainless Steel Ball and Stem



Product Features

Fast quarter turn open or closed operation, Stainless steel ball and stem, Positive shut-off, Two piece body construction

Application

Water-side control of air handling apparatus in ventilation and air-conditioning system.

Water/Steam control in heating systems.

300:1 rangeability.

The dimensions and drilling of end flanges conform to the American cast iron flange standard, Class 150 (ANSI B16.1).

Suitable Actuators

	Non-Spring	Spring	Electronic Fail-Safe
B6300VB-207	SY1, SY2, AMB(X)	2*AFB(X)	GK

Technical Data

Service	chilled or hot water, up to 60% glycol, steam
Flow Characteristic	equal percentage
Controllable Flow Range	75°
Size [mm]	3" [80]
End Fitting	NPT female ends (1" to 2"); ISO flange (3" to 6")
Body	WCC Grade Carbon steel
Ball	stainless steel
Stem	stainless steel
Stem Packing	spring loaded Teflon® V-ring
Ball Seat	Teflon®
Body Pressure Rating [psi]	ASME/ANSI Class 150
Max Inlet Pressure (Steam)	200 psi
Media Temperature Range (Water)	-22°F to 380°F [-30°C to 193°C]
Media Temperature Range (Steam)	-22°F to 380°F [-30°C to 193°C]
Maximum Differential Pressure (Steam)	100 psi
Max Differential Pressure (Water)	150 psi
Maximum Differential Pressure Steam (Rotary Actuator)	100 psi
Close-Off Pressure	150 psi
Close-Off Pressure (Steam)	200 psi
Rangeability	300:1
Cv	207
Weight	37.5 lb [17 kg]
Leakage	ANSI Class IV
Servicing	Repack/Rebuild kits available

Dimensions (Inches [mm])

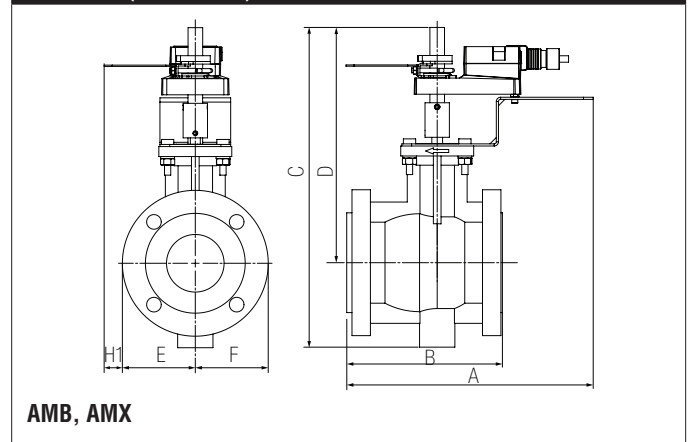

AMB, AMX

A	B	C	D	E	F	H1
12.6" [320]	8" [203]	16.35" [415]	12.05" [306]	3.75" [95]		1.39" [34]

Flow Pattern

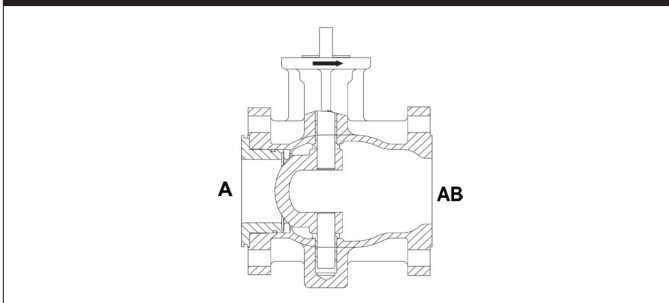

B6300VB-207, 3", V Ball Control Valve

Carbon Steel Body, Hardened Chrome Plated, Stainless Steel Ball and Stem

Dimensions (Inches [mm])

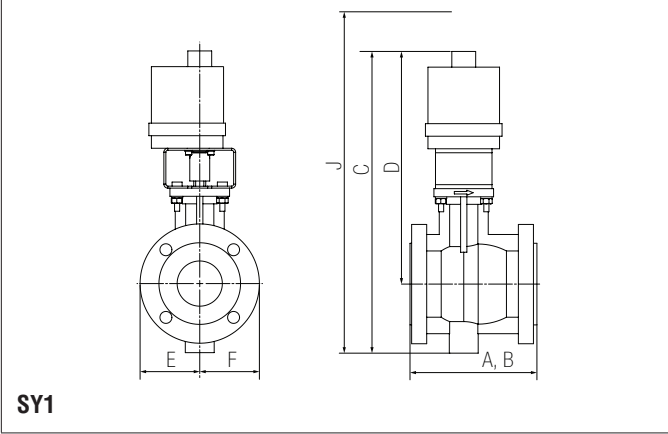

SY1

A	B	C	D	E	F	J
30.87" [784]	8" [203]	18.9" [480]	14.59" [371]	3.75" [95]		23.4" [594]

Dimensions (Inches [mm])

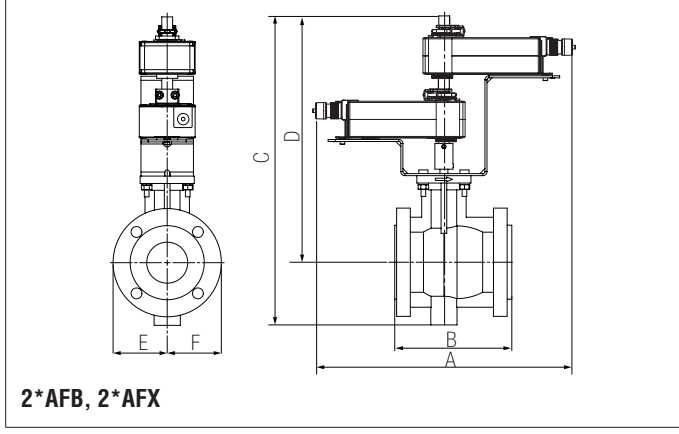

2*AFB, 2*AFX

A	B	C	D	E	F
17.11" [435]	8" [203]	21.55" [547]	17.25" [438]	3.75" [95]	

Dimensions (Inches [mm])

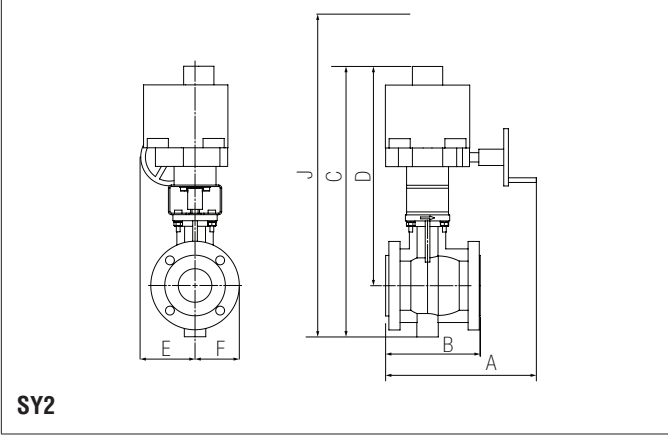

SY2

A	B	C	D	E	F	J
13.25" [337]	8" [203]	22.84" [580]	18.54" [471]	5.15" [131]	3.75" [95]	30.34" [770]

Dimensions (Inches [mm])

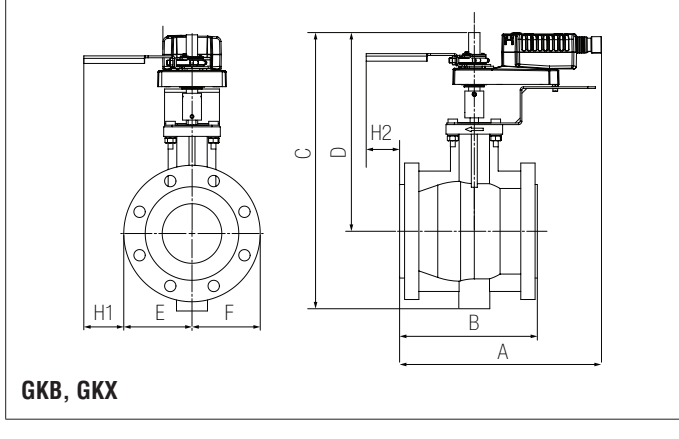

GKB, GKX

A	B	C	D	E	F	H1
13" [332]	8" [203]	17.03" [433]	12.73" [323]	3.75" [95]		1.39" [34]

GKB24-3-X1

On/Off, Floating Point, Electronic Fail-Safe, 24V







Technical Data	
Power Supply	24 VAC \pm 10%, 50/60 Hz
Power Consumption Running	12 W
Power Consumption Holding	3 W
Transformer Sizing	21 VA (class 2 power source)
Electrical Connection	3 ft, 18 GA plenum rated cable with 1/2" conduit connector protected NEMA 2 (IP54)
Overload Protection	electronic throughout 0° to 95° rotation
Operating Range Y	on/off, floating point
Input Impedance	100 k Ω
Angle of Rotation	max. 95°, adjustable with mechanical stop
Direction of Rotation (Motor)	reversible with built-in switch
Direction of Rotation (Fail-Safe)	reversible with switch
Position Indication	reflective visual indicator (snap on)
Manual Override	external push button
Running Time (Motor)	150 sec constant, independent of load
Running Time (Fail-Safe)	35 sec
Bridge Time	2 sec delay before fail-safe activates
Pre-charging Time	5 to 20 seconds
Humidity	5 to 95% RH non condensing (EN 60730-1)
Ambient Temperature Range	-22°F to 122°F [-30°C to 50°C]
Storage Temperature Range	-40°F to 176°F [-40°C to 80°C]
Housing	NEMA 2, IP54, UL enclosure type 2
Housing Material	UL94-5VA
Agency Listings†	cULus acc. to UL60730-1A/-2-14, CAN/CSA E60730-1-02, CE acc. to 2004/108/EC and 2006/95/EC
Noise Level (Motor)	<45 dB (A)
Noise Level (Fail-Safe)	<45 dB (A)
Servicing	maintenance free
Quality Standard	ISO 9001
Weight	4 lb [1.8 kg]

†Rated Impulse Voltage 800V, Type of action 1.AA, Control Pollution Degree 3

Date created, 07/21/2016 - Subject to change. © Belimo Aircontrols (USA), Inc.

Wiring Diagrams

INSTALLATION NOTES

-  Provide overload protection and disconnect as required.
-  Actuators may be connected in parallel. Power consumption and input impedance must be observed.
-  Actuators may be connected in parallel if not mechanically linked. Power consumption and input impedance must be observed.
-  Meets cULus requirements without the need of an electrical ground connection.

WARNING! LIVE ELECTRICAL COMPONENTS!
 During installation, testing, servicing and troubleshooting of this product, it may be necessary to work with live electrical components. Have a qualified licensed electrician or other individual who has been properly trained in handling live electrical components perform these tasks. Failure to follow all electrical safety precautions when exposed to live electrical components could result in death or serious injury.

