

# UGVL Universal Globe Valve Linkage

For Use with LV and SV Series Actuators



Technical Data	
Media	chilled or hot water and steam
Applicable Valve Size	1/2" [13], 3/4" [19], 1" [25], 1-1/4" [32], 1-1/2" [38], 2" [50]
Hardware	SS and Nickel plated steel
Stem Adaptor	aluminum, steel (fits stems up to .66" dia both threaded or slotted.)
Frame, plate, base	aluminum, steel
Collar	aluminum, steel, (fits bonnets up to 1.7" dia both threaded or notched.)
Coupling	GF Nylon supplied
Stroke	0.6" [15 mm] LV, 3/4" [20 mm] SV
Mounting Position	360°
Weight	4.2 lb [1.9 kg]
Media Temp Range (water)	Please Refer to Manufacturer's Valve Specifications

For close-off pressure reference Select Pro or Retrofit Technical Documentation.

## Application

## Operation

### Default/Configuration

The default set up for a UGVL linkage will be factory installed along with a LV or SV series actuator. Included in the kit will be all the necessary hardware to facilitate mounting to the valve.

### Suitable Actuators

	Non-Spring	Electronic fail-safe
UGVL	LVB(X), SVB(X)	LVKB(X), SVKB(X)

### Dimensions (Inches [mm])

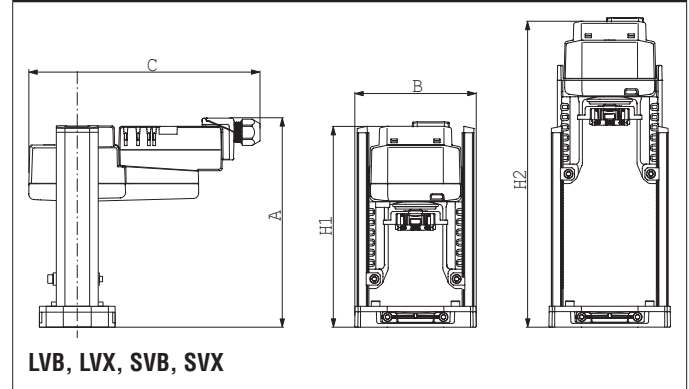

A	B	C	H1	H2
8" [203]	4.4" [112]	8.6" [219]	7.5" [190]	11.4" [290]

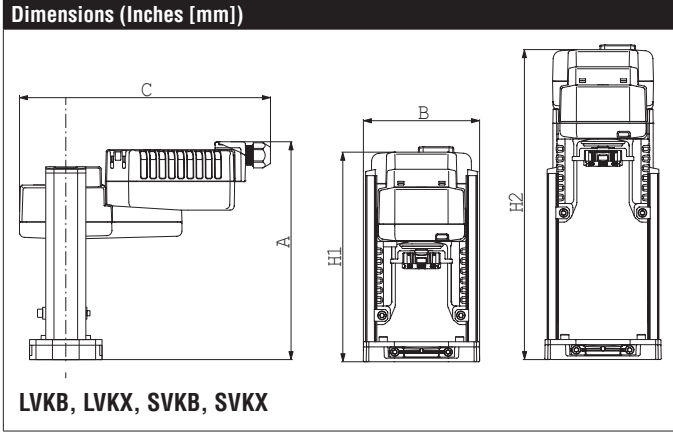

A	B	C	H1	H2
8.5" [216]	4.4" [112]	9.6" [244]	8.4" [207]	12.1" [307]