

EC-BOS-9 Controller with option module

EC-BOS-9

Quick Start Guide

1 Insert Card

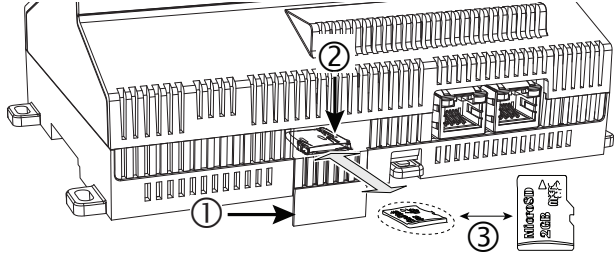

- | | |
|---|----------------|
| 1 | Access Shutter |
| 2 | Card Carrier |
| 3 | MicroSD Card |

2 Install on DIN (1)

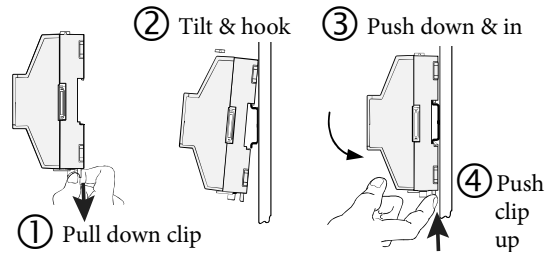

- | | |
|---|-----------------------|
| 1 | Pull down clip |
| 2 | Tilt and hook on rail |
| 3 | Push down and in |
| 4 | Push clip up |

3 Install on DIN (2)

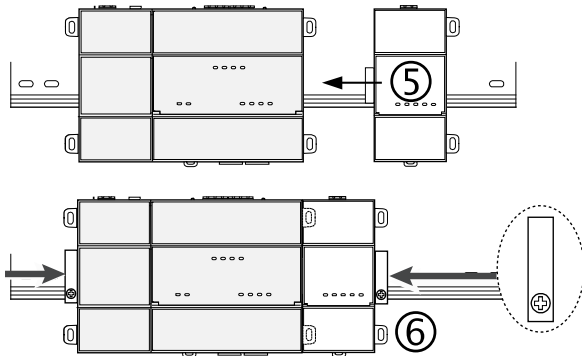

- | | |
|----|-------------------|
| 5. | Install module |
| 6. | Install end clips |

4 Power and Field Communications Ports

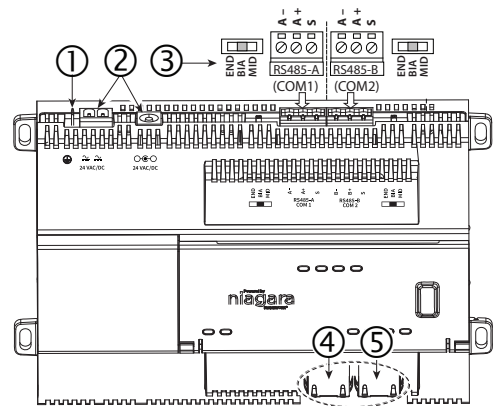

- | | |
|---|------------------------------|
| 1 | Ground |
| 2 | Power |
| 3 | RS485 A/B with Bias switches |
| 4 | Ethernet (Sec) |
| 5 | Ethernet (Pri) |

5 RS485 Example

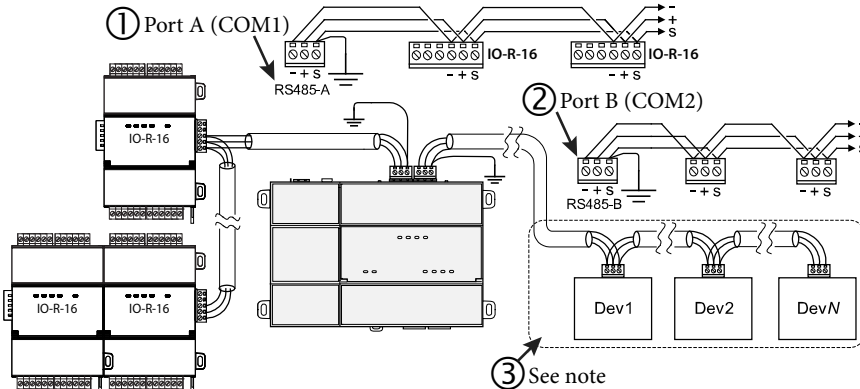

- | | |
|---|---------------|
| 1 | Port A (COM1) |
| 2 | Port B (COM2) |
| 3 | See note |

6 Ground and Power

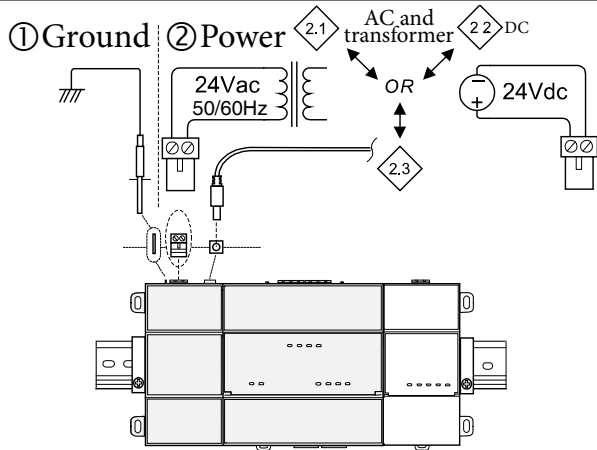

1	Ground
2	Power
2.1	AC and transformer
2.2	DC
2.3	AC adapter

7 LED

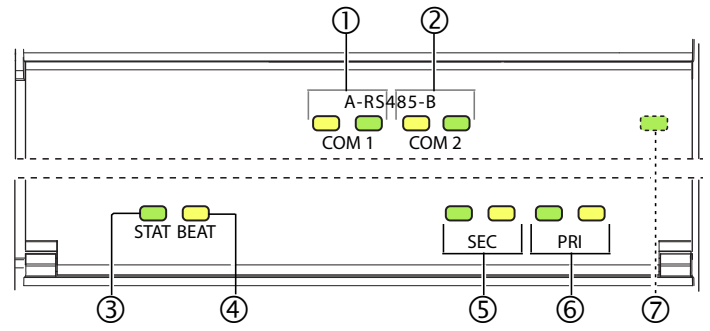

1	RS485-A (COM1)
2	RS485-B (COM2)
3	STAT (Green)
4	BEAT (Yellow)
5	Ethernet (LAN2)
6	Ethernet (LAN1)
7	SHUT DOWN (Green, Behind Door)

8 Ports and Switches

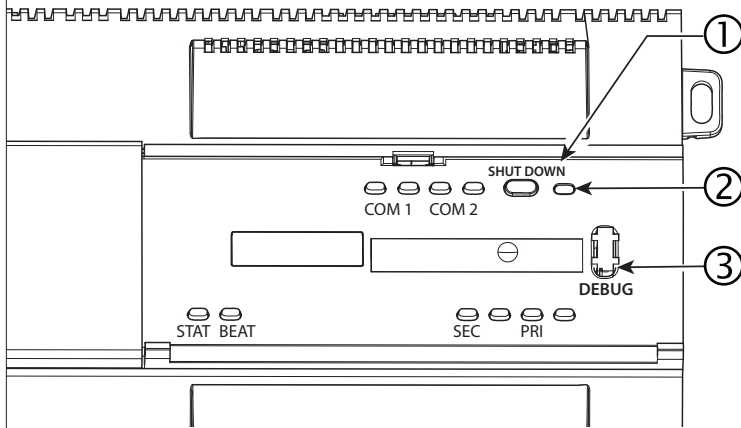

1	SHUT DOWN button
2	SHUT DOWN "Job in progress" LED (Green)
3	DEBUG USB-C

i Option (1)

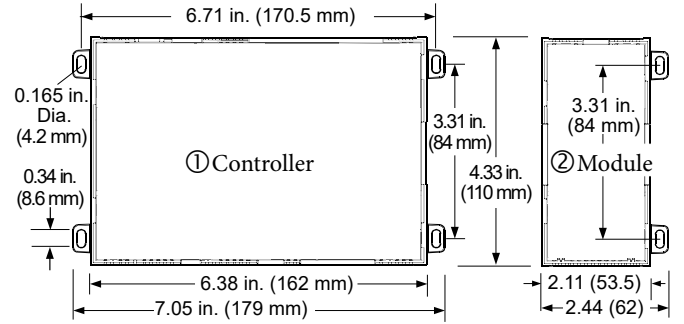

1	Controller
2	Module

i Option (2)

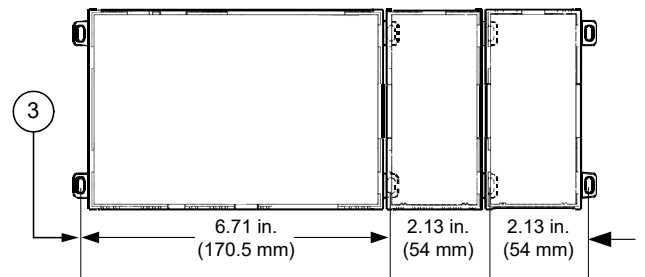

NOTE: A maximum of four (4) total option modules are supported. Separate limits may exist in the controller's license, which can further limit options.

Description

EC-BOS-9

DIN-mount, 24Vac/dc (50/60Hz) powered, area controller. See the product data sheet for complete specifications. See the EC-BOS-9 Mounting and Wiring Guide for complete hardware installation details.

Included in this Package

This package includes the following items:

- EC-BOS-9
- MicroSD card in plastic case. See "Preparation".
- Two 3-position RS485 connector plugs, one 2-position power connector, and a grounding wire.

Material & Tools Required

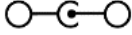
- One of the following:
 - UL listed, Class 2, 24Vac transformer, rated at minimum of 24Va. A dedicated transformer is required (cannot power additional equipment), or
 - User supplied UL Listed Class 2 or LPS AC power adapter: 24Vdc, capable of supplying at least 1A (24W). Optional barrel connector plug (9.5mm L x 5.5mm OD x 2.1mm ID)  or
 - Wall-mount AC power adapter with barrel connector plug.
- DIN rail, type NS35/7.5 (35mm x 7.5mm) and DIN rail end-clips (stop clips), recommended for any installation that includes option modules. You may also mount the Controller on a panel.
- Suitable tools and fasteners for mounting the unit and any accessories.

Preparation

If using a microSD card, insert the card before mounting a new controller.

Install MicroSD Card, see image 1

 Disconnect all power to the controller before removing or inserting the microSD card. Otherwise, equipment damage is likely to occur.

- ① Access shutter for microSD card (slide to open or close.)
- ② Card carrier inside controller.
- ③ MicroSD card to insert or remove from card carrier. Insert card label-side up, until spring catch latches. If properly inserted, the card is behind the shutter track. To remove card, push and release card.

NOTE: The microSD card is used to store backups. Backups, once generated, are encrypted with a system passphrase that is stored in the controller. You must re-enter this same passphrase to restore a backup from the microSD card, using a serial connection to the unit's Debug port.

Warnings:

 Disconnect power before installation or servicing to prevent electrical shock or equipment damage.

 To reduce the risk of fire or electrical shock, install in a controlled environment relatively free of contaminants.

Cautions:

 Remove all power to controller before attaching (plug in) or detaching (unplug) any option module, to prevent possible equipment damage.

 Removal of the controller's cover is not required. No configurable or user-serviceable items (such as jumpers or a battery) require cover removal.

 Protect against unauthorized access to your network systems by restricting physical access to this controller.

Mounting

Mount the controller in a UL approved NEMA Type 1 enclosure. Make sure to provide adequate clearance for wiring, servicing, and module removal.

Environmental Requirements

NOTE: This product is for indoor use only, altitude to 2,000m (6,562 ft.).

Ambient conditions must be within the range of:

- Operating Temperature: -20°C to 60°C (-4°F to 140°F).
- Storage Temperature: -40°C to 85°C (-40°F to 185°F).
- Relative humidity: 5% to 95% non- condensing.
- Pollution Degree 2
- Supply (mains) voltage requirements are:
 - Allowable voltage fluctuation to +/-10%.

NOTE: Horizontal mounting is required to achieve maximum heat dissipation and meet the operating temperature upper limit. Any other mounting orientation reduces this upper limit.

- ① Pull the controller's locking clip down.
- ② Tilt the controller to hook over the DIN rail.
- ③ Push down and in on the unit to fasten to the rail.
- ④ Push the locking clip up to secure.
- ⑤ Mount any option module onto the DIN rail in the same way. Slide the module firmly into the controller's connector to seat.
- ⑥ Repeat for other modules as needed (4 maximum).
- ⑦ Carefully secure both ends of the final assembly with DIN rail end-clips provided by the DIN rail vendor.

Wiring

Power and Field Communications Ports, image 4

Power and field communications ports are as follows:

- ① Ground
- ② Power
- ③ RS485 ports and bias switches
- ④ Ethernet port (Sec), 10/100/1000-Mbit, RJ-45
- ⑤ Ethernet port (Pri), 10/100/1000-Mbit, RJ-45

RS485 Wiring, see image 5

On the controller's top side, two RS485 ports operate as COM1 and COM2. Each port is capable of up to 115,200 baud, and uses a 3-position, screw terminal connector.

NOTE: IO modules, Security modules, and Smartkeys all need to be on an RS-485 network.

Use shielded, twisted-pair, 18-22 AWG cabling to wire in a continuous multidrop fashion to other RS485 devices: "minus to minus", "plus to plus," and "shield to shield."

Connect the shield wire to earth ground at one end only. Image 5 shows example wiring.

- ① RS485 port A (COM1) is often used to support a trunk of T-IO-16-485 modules. NOTE: Do not mix T-IO-16-485s with other types of RS485 devices on the same RS485 trunk.
- ② RS485 port B (COM2) supports a network of field devices using RS485 communication. Additional RS485 COM ports (COM3+) may be added, with port numbering dependent on devices added to each unique system. For example, an Enterprise Security network includes the following:
 - Access network (COM2 default)
 - Smartkey, intrusion keypad (COM3 default)
 - NRIO network
- ③ NOTE: RS485 devices on the same network should use the same protocol and baud rate. Up to 32 or more devices may be supported, depending on device specifications.

RS485 bias switches

Each RS485 port has an adjacent 3-position biasing switch. Settings of each RS485 bias switch are:

- **BIA** - (middle, as-shipped setting) RS485 biasing. 2.7K bias resistors with no termination resistor.
- **END** - RS485 biasing and a termination: 562 Ohm bias resistors and 150 Ohm termination resistor.
- **MIID** - RS485 biasing or termination: 47.5K bias resistors with no termination resistor.

Often, adding RS-485 biasing can improve communications by eliminating indeterminate idle states.

See *EC-BOS-9 Mounting and Wiring Guide* for more details on RS485 biasing. Each RS485 port has two LEDs. See the "Status LEDs" section for more information.

Ethernet Wiring, see image 4

Two RJ-45 10/100/1000-Mbit Ethernet connectors are labeled PRI (LAN1) for primary, and SEC (LAN2) for secondary. Use a standard Ethernet patch cable to an Ethernet switch.

The factory-default IP address for PRI is 192.168.1.140. The default subnet mask is 255.255.255.0. By default, the SEC (LAN2) port is disabled.

Refer to the *EC-BOS-9 Install and Startup Guide* for details on the software configuration of the Ethernet ports.

Earth Ground & Power

Earth grounding provides protection from electrostatic discharge or other forms of EMI.

NOTE: Depending on power source used (image 6).

- ① (AC): Dedicated 24V transformer required, with neither side of the transformer secondary tied to ground.
- ② (DC): Polarity is unimportant (uses onboard diode bridge), with neither leg tied to ground.
- ③ (Wall-mount AC adapter) instead of wiring 24V to 2-position connector.

Wiring Earth Ground & Power, see image 6

 **Warning:** Before making power terminations, de-energize the 24V power source. Do not restore power until completing all other mounting and wiring. See "Power up and initial checkout".

Prerequisite: A nearby earth grounding point.

- ① Install the included earth ground wire to the controller's earth ground spade lug, and terminate the other end to a nearby earth ground.
- ② Unplug the controller's 2-position power connector plug and terminate the 24V supply source (AC or DC) to the connector. Leave connector unplugged for now.

Power Up and Initial Checkout

Apply power by doing one of the following:

- Insert the 2-position 24V power connector plug, or
- Insert the barrel plug of the wall-mount AC adapter.

Check the "BEAT" (Heart- beat) LED.

After power is applied, during bootup, the "BEAT" LED flashes at a 1 Hz rate, at 50%/50% on/off duty cycle. The bootup process will complete approximately 30 seconds after the start of flashing "BEAT" LED.

Status LEDs, see image 7

The controller provides a number of status LEDs, with all but one visible with the front access door closed.

- ① RS485 "A" (COM1): Transmit (TX, Yellow) and Receive (RX, Green).
- ② RS485 "B" (COM2): Transmit (TX, Yellow) and Receive (RX, Green).
- ③ STAT (Green) - Remains illuminated while controller is powered.
- ④ BEAT (Yellow) - "Heartbeat", normally 1Hz, 50% duty cycle.
- ⑤ Secondary Ethernet, SEC (LAN2) "Link" (Green) and "Activity" (Yellow).

⑥ Primary Ethernet SEC (LAN1) “Link” (Green) and “Activity” (Yellow).

⑦ (Behind Door) SHUTDOWN - Green, typically Off.

If the “BEAT” LED stays illuminated constantly, does not light, or blinks very fast, contact System Engineering for technical support.

 Do not remove power from the controller during bootup or during other critical operations, such as firmware upgrade to the controller or any attached modules.

For more details on the controller LEDs and pushbutton switches, see the EC-BOS-9 *Mounting and Wiring Guide*.

USB Ports & Switches, see image **8**

Behind the front access door is one USB port, one pushbutton control, and an associated LED.

① SHUT DOWN - Recessed switch for controlled shutdown.

② SHUT DOWN LED (Green) - Shut down “job in progress” indicator.

③ DEBUG - USB-C port for serial debug communications.

The DEBUG port is a USB-C port for serial debug communications to the controller only. Use a serial terminal program (for example, PuTTY) to access the controller “system shell” menu. This provides access to some basic platform settings.

Default DEBUG port settings are: 115200, 8, N, 1 (baud rate, data bits, parity, stop bits). For details on using a serial connection to the DEBUG port, see the *EC-BOS-9 Install and Startup Guide*.

NOTE: Login requires admin-level platform credentials.

Tab Mounting option, see images **i**

DIN rail mounting is recommended. Where tab mounting is required, use dimensions in the illustration to mount the controller and up to 4 option modules.

 Caution: Do not mount hardware on both a DIN Rail and with tab mounts to another surface. This causes physical stress on equipment and prevents good connections between controller and modules.

① EC-BOS-9 controller with no option modules added. Allow at least 1.5” (38mm) clearance around all sides.

② Option expansion module. Up to 4 may be used.

③ Note distances between center of tabs from one unit to another unit.

More Information

For more information see *EC-BOS-9 Mounting and Wiring Guide*.

WEEE (Waste of Electrical and Electronic



Equipment)

This symbol on our product shows a crossed-out “wheeled bin” as required by law regarding the Waste of Electrical and Electronic Equipment (WEEE) disposal. This indicates your responsibility to contribute in saving the environment by proper disposal of this Waste i.e. Do not dispose of this product with your other wastes. To know the right disposal mechanism please check the applicable law.



Specifications subject to change without notice.

ECLYPSE, Distech Controls, the Distech Controls logo, EC-Net, Allure, and Allure UNITOUCH are trademarks of Distech Controls Inc. BACnet is a registered trademark of ASHRAE; BTL is a registered trademark of the BACnet Manufacturers Association. The Bluetooth® word mark and logos are registered trademarks owned by Bluetooth SIG, Inc. and any use of such marks is under license. All other trademarks are property of their respective owners.

©, Distech Controls Inc., 2021 - 2024 All rights reserved.

Global Head Office - 4205 place de Java, Brossard, QC, Canada, J4Y 0C4 - EU Head Office - ZAC de Sacuny, 558 avenue Marcel Mérieux, 69530 Brignais, France

EC-BOS-9_Quick_Start_IG_10_EN