

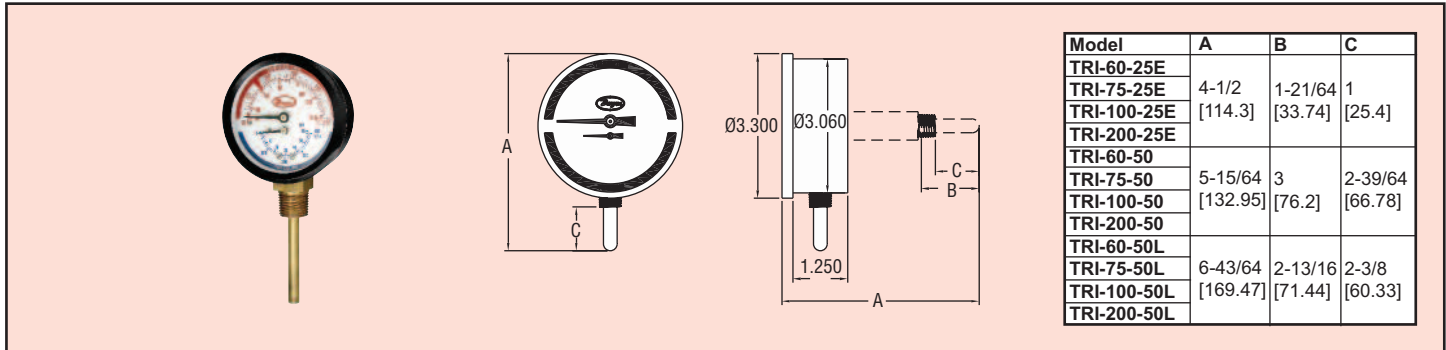

Series TRI Tridicator Gage Combination Pressure/Temperature Gage



Model	A	B	C
TRI-60-25E			
TRI-75-25E	4-1/2	1-21/64	1
TRI-100-25E	[114.3]	[33.74]	[25.4]
TRI-200-25E			
TRI-60-50			
TRI-75-50	5-15/64	3	2-39/64
TRI-100-50	[132.95]	[76.2]	[66.78]
TRI-200-50			
TRI-60-50L			
TRI-75-50L	6-43/64	2-13/16	2-3/8
TRI-100-50L	[169.47]	[71.44]	[60.33]
TRI-200-50L			

The Series TRI combines the value of an individual pressure gage and thermometer in one instrument. These tridicators simplify installation which reduces time and saves money. The moveable dial with blue pressure markings and red temperature markings make the instrument easy to read. Pressure is indicated in both psi and kPa, while temperature is measured in both Fahrenheit and Celsius. Series TRI comes in three different connection options including lower mount, center back mount, and center back mount with extension shank.

Model	Range	Connection
TRI-60-25E	0-60 psi (0-400 kPa)	1/4" NPT CBM (ext. shank)
TRI-75-25E	0-75 psi (0-500 kPa)	1/4" NPT CBM (ext. shank)
TRI-100-25E	0-100 psi (0-700 kPa)	1/4" NPT CBM (ext. shank)
TRI-200-25E	0-200 psi (0-1400 kPa)	1/4" NPT CBM (ext. shank)
TRI-60-50	0-60 psi (0-400 kPa)	1/2" NPT CBM
TRI-75-50	0-75 psi (0-500 kPa)	1/2" NPT CBM
TRI-100-50	0-100 psi (0-700 kPa)	1/2" NPT CBM
TRI-200-50	0-200 psi (0-1400 kPa)	1/2" NPT CBM
TRI-60-50L	0-60 psi (0-400 kPa)	1/2" NPT LM
TRI-75-50L	0-75 psi (0-500 kPa)	1/2" NPT LM
TRI-100-50L	0-100 psi (0-700 kPa)	1/2" NPT LM
TRI-200-50L	0-200 psi (0-1400 kPa)	1/2" NPT LM

SPECIFICATIONS

Service: Compatible gases and liquids.

Wetted Materials: Brass connection and phosphor bronze Bourdon tube.

Housing: Drawn steel, black finish.

Accuracy: Pressure ± 3 -2-3%; Temperature ± 1 scale division.

Temperature Range: All models: 80 to 290°F (30 to 140°C).

Temperature Limits:

Ambient: -40 to 250°F (-40 to 120°C);

Process: 80 to 290°F (30 to 140°C).

Pressure Limits: Full scale range.

Size: 3" (76 mm).

Process Connections: 1/2" male NPT back or bottom, 1/4" male NPT back connection.

Weight: 12.3 oz (348.7 g).

USA: California Proposition 65

⚠ WARNING: Cancer and Reproductive Harm - www.P65Warnings.ca.gov