

# EAGLE X PRO D6C / D6I / D6 / D6MAX

## SURFACE MOUNT D6 SERIES



The Eagle X Pro D6 Series Surface Mount Models D6C / D6i/ D6 / D6Max are powered by our patented Corona Discharge Bipolar Ionization technology. This technology allows for continuous production of an equal amount of positive and negative ions at the highest density available on the market.

Our D6 Series Surface Mount Units are installed in-line to the duct work of an HVAC system and operate on 12V DC - 24V AC. The D6 Series Chips is capable of ionizing a supply airflow of 1,500 up to 10,000 CFM (depending on the model selected).

### SPECIFICATIONS:

<b>CFM Recommendations</b> .....	2400-3600 CFM (D6C)
.....	3600 to 5200 CFM (D6i)
.....	5200 to 6900 CFM (D6)
.....	6800 to 10000 CFM (D6MAX)
Ion output (Ions/Sec).....	D6C- 20B (10 <sub>9</sub> *2); D6I – 50B (10 <sub>10</sub> *5);
.....	D6 - 100B (10 <sub>11</sub> ); D6MAX – 1T (10 <sub>12</sub> )
Emitter cleaning .....	Self-cleaning – maintenance free
Emitter Points .....	Tungsten
Input voltage .....	12 VDC - 24 VAC
Operating environment .....	
.....	Temp. (41°F) – (140°F), Hum. 20-80% non-condensing
Storage environment .....	
.....	Temp. (14°F) – (158°F), Hum. <85% non-condensing
Ambient Airflow .....	Minimum 11.8 inch/sec laminar
Ozone .....	< 0.001 ppm
EMI .....	Below background levels (rec. 3.464 inches distance)
CFM .....	D6C- up to 1,500; D6I – up to 3,200;
.....	D6 – up to 6,800; D6MAX – up to 10,000
LED indicator .....	green: power “on” orange: “operation”
Connector power .....	12 VDC - 24 VAC
Connector output .....	On/Off; optional I/O; optional I/O; common
Connector interface .....	RS485 Modbus (up to 247 units)
Enclosure .....	PC-ABS plastic blend, color grey (black)
Dimensions .....	3.82x2.9x0.96 Inches (LxWxH)
Chip Weight .....	0.322 Lb
Certifications .....	UL, CSA, CE, IEC, FCC, RoHS 2 compliant

### For Static Control

Ion Balance .....	Inherently self-balancing system < ± 30V
Discharge time 1 .....	
1000V – 100V @ < 3 sec at 11.82 inches with air flow 39.4 inch/sec	
Discharge time 2 .....	
1000V – 100V @ < 6 sec at 23.63 inches with air flow 39.4 inch/sec	
Discharge voltage 1 .....	< 30 V at 11.82 inches
Discharge voltage 2 .....	< 10 V at 23.63 inches

### DIMENSIONS: SEE FIGURE 1

### STATUS INDICATOR:

The LED indicator function provides an electronic signal only when the unit is operating properly, i.e. when the unit is emitting ions.

### NEUTRALISES AND ELIMINATES:

Viruses, Bacteria, Mold Spores, Fungus, Pollen, Animal Dander.

### WHICH CAN CAUSE:

Infection, Allergies, Asthma, Flu, Fever, Odor & Mildew.

### CERTIFICATIONS: UL 867, UL 2998

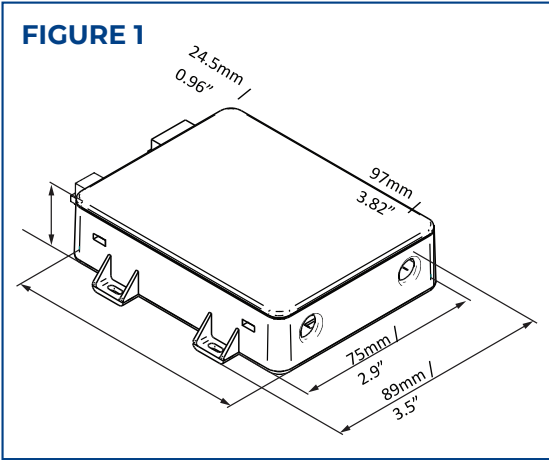

**EAGLE X PRO**

5415 CAMERON STREET SUITE 121, LAS VEGAS, NEVADA 89118  
 phone 833.324.5397 • www.eaglexpro.com • office@eaglexpro.com

©2021 All rights reserved