



Class 3200 Meter

ADVANCED KWH/DEMAND METER

INSTALLATION INSTRUCTIONS



CLASS 3200 METER

Dear Valued Customer,

We are pleased that you chose to buy one of our products, and want you to be just as pleased with owning it. Before installing your new E-Mon product, please read the information on the following pages carefully.

We believe that you will find the E-Mon D-Mon meters easy to install and to use for monitoring and evaluating your electrical usage.

To be sure that you are 100% satisfied with your products, we provide toll-free technical and sales support Monday through Friday, 8:00 am to 7:30 pm, EST: (800) 334-3666. You may also reach us via email at info@emon.com.

If you have questions, we can handle them quickly and effectively with a telephone call. Please let us try to help you BEFORE you remove your meter. And to help us help you, we ask that you have all relevant information on hand when you call (model or part numbers, nature of difficulty, etc.)

Be sure to forward this manual to the owner after installation is complete, so that they may use it as a reference guide when reading the E-Mon D-Mon meter.

Thank you.

TABLE OF CONTENTS

Section 1.0	Introduction	4
Section 2.0	Internal Electronic Assemblies	6
Section 2.1	Main Power Board	6
Section 2.2	Display Board	7
Section 3.0	Meter Technical Specifications	8
Section 4.0	Safety Label Definitions and Information	10
Section 5.0	Precautionary and Safety Information	11
Section 6.0	Meter Installation	12
Section 6.1	Mounting the Class 3200 Meter	12
Section 6.2	Main Power Board Connections	12
Section 6.3	Phasing of Line Voltage	15
Section 6.4	Current Sensor Installation & Wiring	16
Section 6.5	Main Power & Current Sensor Wiring Diagram	18
Section 6.6	Line Voltage/Current Sensor Diagnostics	18
Section 6.7	RS-485 Wiring	19
Section 6.8	RS-232 Communications	22
Section 6.9	Modem Wiring	24
Section 6.10	Modbus RTU Wiring	27
Section 6.11	BACnet MS/TP Wiring	28
Section 6.12	Connecting Class 3200 Meters to USB Key using RS485	28
Section 6.13	Ethernet Communications	29
Section 7.0	Multiple-Load Monitoring	30
Section 8.0	Preventative/Scheduled Maintenance	31
Section 9.0	Lithium Battery Replacement	32
Section 10.0	Class 3200 Meter Operating Modes	34
Section 10.1	Start Up Screens	34
Section 10.2	Normal Mode Display Screens	35
Section 10.3	How to Program the Display Screens	36
Section 11.0	High Voltage Metering	41
Section 12.0	Class 3200 Protocol Definitions	45
Section 13.0	Meter Limited Warranty	51

1.0 INTRODUCTION

The E-Mon D-Mon® Class 3200 meter is a 3-element meter with communications. The device is used to monitor electric power usage of individual loads after the utility meter and store kW and kVAR data for automatic meter reading. Installation must only be performed by qualified personnel and in accordance with these instructions and all applicable local and national electrical codes. E-Mon and its representatives assume no responsibility for damages or injury resulting from the improper installation of this meter.

Verify the input voltage rating and configuration on the unit panel label to ensure that it is suitable for the intended electrical service. Class 3200 meters labeled for 120/208V service **MUST NOT** be installed on service feeds of 277/480 volts or 347/600 and vice versa.

Verify that the Class 3200 meter's current sensors are sized suitably for the load to be monitored. Compare the color of the arrows on the current sensors to the chart below to confirm the correct current sensor is being used.

Sensor Arrow Color Code	Sensor Rating
Brown	100 A
Red	200 A
Yellow	400 A
Black	800 A
Blue	1600 A
White/Black	3200 A



CAUTION

Internal circuit components are extremely sensitive to electrostatic discharge. Prior to handling or touching internal circuitry, discharge any static buildup on your person. To discharge yourself, touch a grounded metal object such as conduit or an earth-grounded enclosure.



WARNING

Use of this instrument, the E-Mon D-Mon Class 3200 meter, in a manner inconsistent with this manual or not specified by the manufacturer in writing, can cause permanent damage to the unit and/or serious injury to the operator. The protection and safety features provided by this equipment may become impaired or otherwise compromised.

NOTE: If any trouble arises during the installation or functional verification operations, do not immediately remove the unit. Before removing the unit, contact E-Mon's technical support and/or engineering department at (800) 334-3666. E-Mon's technical department will assist you in detailed troubleshooting of the Class 3200 meter installation and assist you in getting the unit operating correctly.

2.0 INTERNAL ELECTRONIC ASSEMBLIES

The units are comprised of two major subassembly boards, the main power board and the display board. Both circuit boards are mounted inside a UL Type 1 or Type 4X enclosure.

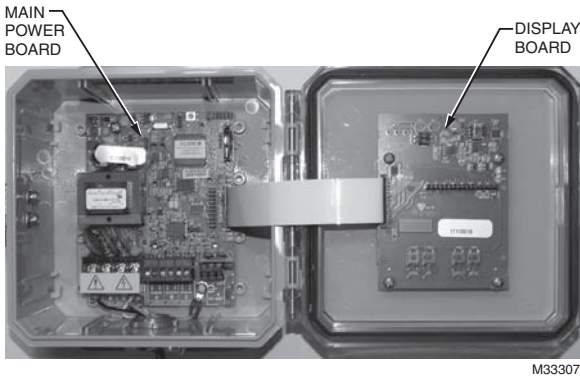

Fig. 1. Internal Electronic Assemblies.

2.1 Main Power Board

Connections to this board include the MAIN Power Input and current sensors. The MAIN Power Input terminals are positions one through four on the four position screw terminal block, TB1. These terminals are covered with a protective shield for safety purposes. The current sensor assemblies interface to TB2, TB3 and TB4. Each terminal block corresponds to an input voltage phase; care must be exercised to ensure that each current sensor is connected to the correct terminal block. One three terminal screw connector is provided for RS-485 communications.

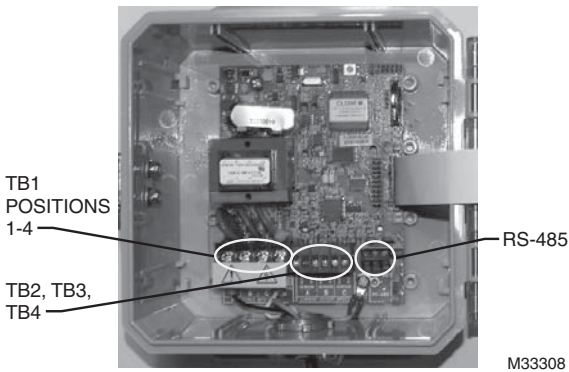

Fig. 2. Main Power Board Connections.

2.2 Display Board

The display board connects to the main power board via a flex ribbon cable and the board mounts on the inside of the housing door.

The Class 3200 meter features a 4-line LCD display that indicates multiple meter data points.

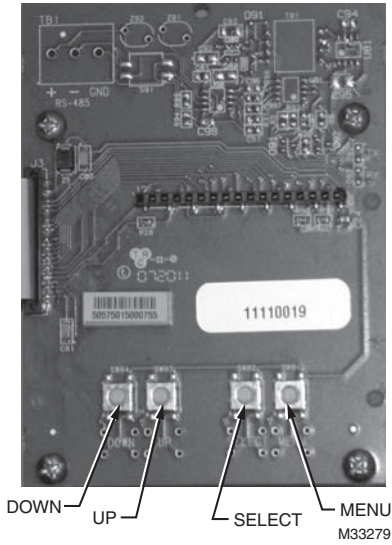
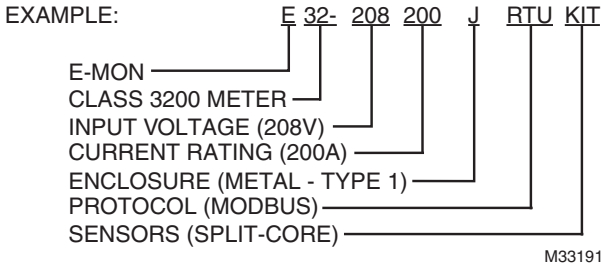

Fig. 3. Display Board.

3.0 METER TECHNICAL SPECIFICATIONS

Ordering Information: Define brand, class, input voltage, amperage, protocol, and sensor type in the format A-BB-CCC-DDDD-E-FFF-GGG, where

- A = Brand: E for E-Mon
- BB = designates Class: 3200 (32), 3400 (34), or 5000 (50) meter
- CCC = input voltage: (208, 480, 600, 120 volt for High Voltage)
- DDDD = current rating: (100, 200, 400, 800, 1600, 3200, 25HV)
- E = enclosure: J = metal (type 1), R = non-metallic (type 4X), M = MMU
- FFF= protocol: RTU = Modbus, BAC = BACnet, EZ7 = proprietary
- GGG = Sensors: KIT = split-core, SCS = solid-core, "blank" = none supplied



Input Voltage Configuration	3-wire (delta) Or 4-wire (wye)
Mains Voltage Input	Up To 600 VAC RMS available
Input Power	6 VA maximum rating
Current Sensor Rating	Up To 3200 amps RMS AC available
Power Factor	0.5 leading or lagging
Line Frequency	50-60 Hz
Metering Accuracy	ANSI C12.20
Temperature Range	-20C to +50C
Relative Humidity Range	0-95% non-condensing
Altitude	2000 meters maximum
Voltage Overload	+25% continuously: +100% For 20 cycles
Current Sensor Overload	100% for 1 minute
Pollution Degree	Degree 2 in accordance with IEC 664
Installation (Overvoltage) Category	Category III
Measurement Category	Category III

3.0 METER TECHNICAL SPECIFICATIONS (CONTINUED)

Enclosure Material	UL Type 1 or Type 4X	
Display Readout	LCD	
Standard Ranges	(4-Wire Wye) 208 VAC: 100, 200, 400, 800,1600, 3200 Amp (3-Wire Delta) 240 VAC: 100, 200, 400, 800,1600, 3200 Amp (4-Wire Wye) 480 VAC: 100, 200, 400, 800,1600, 3200 Amp (3-Wire Delta) 480 VAC: 100, 200, 400, 800,1600, 3200 Amp (4-Wire Wye) 600 VAC: 100, 200, 400, 800,1600, 3200 Amp	
RS-485 Serial Communications Cable	Cable:	UL-listed/rated/3-conductor, 300 VAC, stranded conductors, 22-26 AWG.
	Input/output Voltage:	Ground-isolated +/-5.4Vdc
	Cable Connector:	Screw terminal termination
	Circuit Input Isolation:	5.3kVAC
	Max Cable Distance:	4000 feet
	Max Network Nodes:	64 cabling nodes (including master)
	Baud Rate:	9600, 19200, 38400, 76800
Recommended In-Line Fuse	Manufacturer:	Littlefuse
	Mfg. Part No:	KLDR.100
	Rating:	100mA, time-delay, 600VAC cartridge fuse
Battery Cell:	Description:	Non-rechargeable cell used for memory retention
	Manufacturer:	Panasonic
	Mfg Part No:	CR2032
	Working Voltage:	3Vdc
	Current Capacity	225 mAhR
	Electrolyte:	Manganese Dioxide Lithium

4.0 SAFETY LABEL DEFINITIONS AND INFORMATION

The 3200 meter may contain one or more of the following labels. Operator(s) should familiarize themselves with the meaning of each label to minimize risk.



The presence of this label is a cautionary indicator identifying a danger risk. The manual should be consulted prior to proceeding.



The presence of this label indicates an electrical shock hazard exists in the location or area where the label is placed. Prior to proceeding, the MAINS power must be disconnected and the manual consulted for safety information.

5.0 PRECAUTIONARY AND SAFETY INFORMATION



CAUTION

Internal circuit card components are extremely sensitive to electrostatic discharge. Be careful not to touch internal circuitry prior to discharging any static buildup on your person. To discharge yourself, touch a grounded metal object such as conduit or an earth-grounded metal enclosure.



WARNING

High voltages present on main PCB terminal block TB1 screw terminals. Risk of serious injury and/or electrical shock exists. Prior to performing any wiring operations, review all contents of the user manual and de-energize the MAINS power switch. Only qualified personnel should perform installation wiring. Installation wiring must comply with all local and national electrical codes.



WARNING

Failure to ground the enclosure creates a possible shock hazard. Do not operate the Class 3200 meter without a protective earth wire attached securely to the PE terminal screw. After installing protective earth wiring, secure the screw tightly (7in-lb torque.)



WARNING

NEVER open front panel of unit while unit has MAINS power applied. Failure to comply can increase the risk of serious injury and/or electrical shock.

6.0 METER INSTALLATION

6.1 Mounting the Class 3200 Meter

Use appropriately sized mounting hardware to fasten the Class 3200 enclosure to the selected mounting surface. The four housing mounting holes are centered 6.75" H x 4" W. When the meter is provided in the 4X rated enclosure, the hub must be mounted to the conduit first before connecting it to the enclosure.

NOTE: Units housed in UL type 1 enclosures must only be installed in indoor locations, where they will not be affected by the elements.

6.2 Main Power Board Connections

1. Installing a temporary ground for ESD protection: With all circuits de-energized, connect a temporary protective earth ground connection for ESD protection. Prior to performing any unit wiring, be sure to discharge any static on your person.
2. Installing the Class 3200 protective earth ground: Connect an earth ground wire to the Class 3200 (Type 1 enclosure) protective earth ground lug with a torque of 7 N-m.

WARNING

Failure to attach the protective earth ground wire securely to the meter creates a potential shock hazard. Do not loosen or remove the screw securing the ground lug.

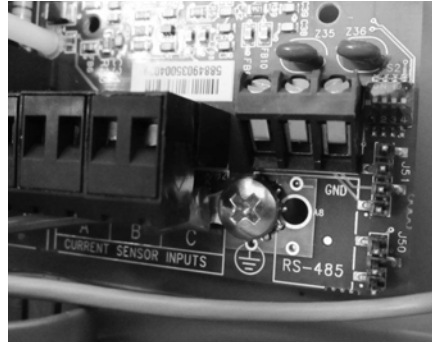

Fig. 4. Main Power Board Connections.

6.2 Main Power Board Connections (continued)

3. *Wire Entry:* One 3/4" conduit opening is located on the bottom of the CL3200 enclosures. This opening is used for bringing in MAINS power and for current sensor wiring. One 1/2" conduit opening on the top of the metal enclosure CL3200 can be utilized as an interface for the low-voltage signals, pulse input, or RS-485 communications wiring to the unit. CL3200 meters are available in an MMU (Multiple Meter Unit) enclosure that holds eight (8) meters. This enclosure comes without knockouts and allows the user to choose entry points for the wiring.

Any unused openings must be sealed with a UL rated plugging device or hub suitable for the rating of the enclosure - such as NEMA 1 or 4X.

4. Unit MAINS wiring:

The four positions on terminal block TB1, located at the bottom left corner of the main power board, are clearly labeled Phase A, B, C, N (neutral). Earth Ground **MUST** be connected to the PCB mounting screw in the lower right corner.

- A. Connect the NEUTRAL wire to the appropriate terminal block position.

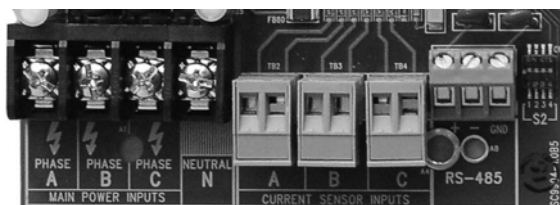

Fig. 5. Terminal Block TB1, TB2, TB3, and TB4.

NOTE: For 3-wire delta-type applications, do NOT connect the NEUTRAL wire. Remove the terminal block screw for this position.

- B. Earth Ground

Connect the Earth Ground to the PCB mounting screw in lower right corner.

- C. External Switch Mechanism/In-Line Fuse Installation

To ensure a safe installation, the Class 3200 meter requires an external switch mechanism, such as a circuit breaker, be installed on the meter's MAINS input wiring. The switch mechanism must be installed in close proximity to the meter and easily reachable for the operator. This device must also be marked as the disconnecting device for the Class 3200 meter. 1/10 Amp Slow Activation in line fuses (KLDR.100, UL listed, Littelfuse rated 600V/100ma) must be installed for each conductor phase at the MAINS input to the meter. The fuses must be labeled to indicate voltage and current rating as well as element characteristics. The fuse element must be slow activating type.

6.2 Main Power Board Connections (continued)

- D. Connect the three AC main power wires (Phases A, B and C) to their respective positions as labeled on terminal block TB1. After all conductors are connected to each of their respective terminal block positions and tightened to 7 in-lb, verify that each terminal block screw is securely fastened by gently tugging on each conductor. Verify that no conductor wires are frayed or shorting to adjacent terminal block positions.
- E. Turn ON the AC main power input. The meter display will light up and scroll through 6 displays. Each display is visible for 5 seconds. Display screens are as follows:

Screen 1 - Total kilowatt-hours (kWh) consumed
Screen 2 - Peak demand (kW) with date & time stamp
Screen 3 - Actual load (kW)
Screen 4 - RMS Amps
Screen 5 - RMS Volts Phase to Neutral
Screen 6 - RMS Volts Phase to Phase
Screen 7 - Power factor (PF) per phase

- F. Verify the voltage readings on Screen 5 using an AC voltmeter. Typical readings shown below are measured phase to neutral (L-N) for 4 wire and phase to phase (L-L) for 3 wire. Readings should be +/- 10% of nominal.

Meter Type	Nominal Voltage	Limits (+/- 10%)
208V, 3 ϕ , 4 Wire	120 VAC (L-N)	108 to 132 VAC
480V, 3 ϕ , 4 Wire	277 VAC (L-N)	249 to 305 VAC
600V, 3 ϕ , 4 Wire	347 VAC (L-N)	312 to 380 VAC
240V, 3 ϕ , 3 Wire	240 VAC (L-L)	216 to 264 VAC
480V, 3 ϕ , 3 Wire	480 VAC (L-L)	432 to 528 VAC

NOTE: Meters are powered by phases A and B. The displayed voltages will be the measured AC voltage between phases.

6.3 Phasing of Line Voltage

The 3-phase AC power input must be in proper phase sequence. If the sequence is incorrect or a phase is missing, there will be a message on the meter's display: "PH Sequence Error" or "PH Missing:.". (Refer to the section on Line Voltage Diagnostics if this message is present.) When the line voltage is connected correctly, the meter's display will be blank (no message.)

Wait for the 4-line meter display to scroll to the voltage display. Verify that the meter reads correct voltages on all three phases. Repeat Step 6.2.4F.

Once the meter displays the correct line voltages and there are no error messages, you are ready to connect the current sensors to the meter. Before continuing with the installation, verify that the six screens display as follows:

Screen 1 (kWh):	Should read 0.0 kWh; if not, should be reset.
Screen 2 (kW Peak Demand):	kW peak should read 0.0 kW. There will not be a date/time stamp yet. If there is a kW peak recorded, it should be reset later.
Screen 3 (kW Load):	Should read 0.0 kW load.
Screen 4 (Amps per Phase):	There should be 0.0 on all three phases.
Screen 5 (Volts RMS Phase to Neutral):	See the section 6.2.4.F.
Screen 6 (Volts RMS Phase to Phase):	See the section 6.2.4.F.
Screen 7 (Power Factor Per Phase):	There should be 0.0 PF on all three phases.

NOTE: The meter will be reset later via the software during "startup" procedures.

6.4 Current Sensor Installation & Wiring

Once the AC voltages have been confirmed to be within acceptable limits, you are ready to install the current sensors. TB2 is the input for Phase A, TB3 is the input for Phase B and TB4 is the Phase C input.

The Class 3200 meter can be used with two types of current sensors:

1. Split-core current sensor. This sensor opens so that it can be attached around the circuit being monitored without interrupting power.
2. Solid-core current sensor. This sensor does not open and requires the monitored conductor to be removed from the circuit to install the current sensor. This type is only supplied when specified at time of order.

NOTE: It is recommended that a UL listed current sensor be used for this application.

6.4.1 Installing the Split-Core Current Sensor Assembly

1. Each phase being monitored will require one two-piece current sensor assembly. Open the two-piece current sensor assembly by releasing the nylon clamp using a flathead screwdriver.



Fig. 6. Split Core Sensor.

2. Reassemble the current sensor assembly around the conductor(s) to be monitored. Ensure the current sensor halves marked “Load” are both facing the load side of the conductor. The colored arrow will be on the source side of the conductor being monitored and **MUST** be pointed in a clockwise direction around the conductor being monitored. Tighten the nylon clamp to complete the assembly.

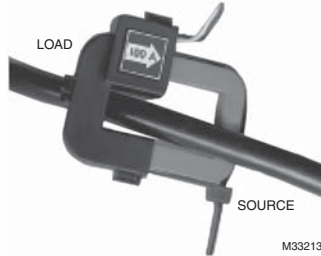

Fig. 7. Split Core Sensor.

IMPORTANT:

When looking from the source side of the conductor(s) being monitored, you should see the arrow on the current sensor assembly. The arrow should be pointing in a clockwise direction around the conductor(s) being monitored. If the arrow is not positioned on the source side, inaccurate readings will result.

6.4.1 Current Sensor Wiring

Once the current sensors are installed onto their appropriate phase conductors, you can begin terminating the current sensors onto the Class 3200 main board. The current sensors can be extended up to 500 feet for remote monitoring applications. To extend the length of the wires, use #22 AWG twisted-pair wire with one white and one black wire.

The easiest way to connect the current sensors is to use the meter's built-in current sensor diagnostics. To do this, there must be at least 1% of the meter's current rating (amps) flowing in each of the conductors being monitored. The Class 3200 meter's diagnostic program (on the 4-line display) will provide data to ensure that the current sensor installation is done properly.

The current sensor connection points are located at the bottom right of the main power board. These are TB2, TB3, and TB4. Each sensor connects to two terminals one labeled "Black" and the other "White." Current sensors should be connected to the meter one at a time and verified using the current sensor diagnostic program.

Connect one of the current sensors to the TB2 terminals (Phase A). Tighten the terminal to 4.5 in-lb. Wait 5 seconds and look at the meter display.

If the meter displays an error message (see below), remove the wires from TB2 (Phase A) and install them on TB3 (Phase B). If an error message occurs with the sensor attached to TB3, try again on TB4 (Phase C). The wiring will be correct when the error indication message is gone.

NOTE: If the power factor being monitored is <65%, the error message may be activated until improved. This is normal and indicates poor power factor.

The "CT Error: * "message will disappear when the current sensor is connected to the correct terminals (phase).

Error Messages: CT ERROR: A
CT ERROR: A B
CT ERROR: A C

Refer to the section on Current Sensor Diagnostics for assistance in troubleshooting these errors.

6.4.2 Main Power

After the meter circuit wiring has been examined for correctness, power may be applied to the circuit board. There are three LEDs located in the upper right corner of the Meter Board labeled BEAT, STATUS and LOAD. The BEAT and STATUS LEDs will blink once per second when the meter is operating normally, twice per second if there is a problem. If the monitored circuit is under load the LOAD LED will actively blink. A heavy load will cause the LED to blink faster than a light load. Very light loads will result in an extended blink time.

6.5 Main Power & Current Sensor Wiring Diagram

3-PHASE, 4-WIRE INSTALLATION DIAGRAM

NOTES:

LINE VOLTAGE CONNECTIONS: #14-12 AWG

SENSOR CONNECTIONS: B = BLACK LEAD W = WHITE LEAD

NEUTRAL NOT USED IN DELTA SYSTEM. REMOVE NEUTRAL TERMINAL BLOCK SCREW FOR DELTA SYSTEMS.

 1/10A 600 VAC INLINE FUSE PER CONDUCTOR. LITTFUSE PART NUMBER KLDR.100.

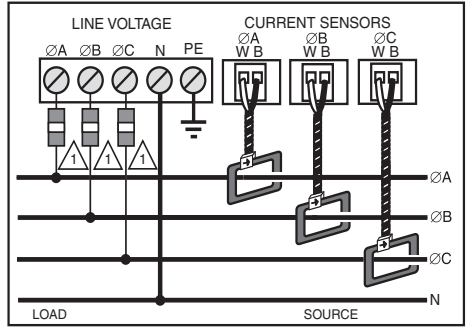

M33185

Fig. 8. 3-phase- 4 Wire Installation Diagram

6.6 Line Voltage/Current Sensor Diagnostics

Following is a list of diagnostic messages that may appear on the meter display. DIAGNOSTIC MESSAGES SHOULD NOT BE ON CONTINUOUSLY WHEN THE METER IS INSTALLED PROPERLY AND IS IN WORKING ORDER.

6.6.1 Line Voltage Diagnostics

The diagnostics program detects line voltage faults by displaying one of two messages:

PH Missing: B C or Phase sequence error.

Phase sequence error indicates that the 3-phase line voltage is not hooked up in the proper phase sequence. This message should never be seen continuously on the display during normal operation. The meter will not display correct electrical data in this condition. The phase sequence problem must be remedied in order for the meter to work properly.

Missing: B C indicates that the line voltage is missing on Phase B and/or Phase C. This message will appear whenever the power on either Phase B or Phase C is off. Screen 5 (Voltage per Phase) will also indicate a loss of line voltage.

6.6.2 Current Sensor Diagnostics

The load current must be at least 1% of the meter's rated load in order to use the diagnostic function. Current sensor diagnostics can detect:

1. Reversed current sensors
2. Incorrect phase correspondence
3. Unusually low power factor (0.642 or lower)

CT Error: (ABC) is used to detect the swapping of current sensor phases. This message could (in some rare cases) indicate a low (<65%) power factor condition. This message may appear intermittently due to changes in line conditions. It should not be on continuously. (See Section 6.4.1.)

NOTE: If you have connected the current sensor to all three terminals and the error message is still appearing, reverse the black and white wires and repeat the previous steps until the correct connection is found.

If the *CT Error:* message disappears, you have found the correct sensor connection; however, the current sensor was not installed properly around the conductor, or the sensor wires were extended and not spliced together correctly. Correct the sensor installation, reconnect the black wire to the black terminal and the white wire to the white terminal on the plug and reinstall the plug into the correct phase terminal for that current sensor. The error message should disappear and the current sensor is now installed properly.

If the *CT Error:* message does not disappear at any time while trying all 3 inputs both ways, check the AC voltage input from the current sensor between the black and white wires using an AC voltmeter. It will read approximately zero volts indicating that the load current is very small (or zero) or the current sensors are not secured properly (tight connection between core halves or lead splices not secure.)

Once the first current sensor is connected properly and the error message disappears, repeat the previous procedure for the remaining two current sensors. When all error messages have disappeared and all sensors are installed correctly, the meter is operational.

6.7 RS-485 Wiring

RS-485 communication allows a computer or modem to communicate with one or more Class 3200 meters. You can connect as many as 52 meters along a 4000 foot RS-485 cable run.

There are two communication protocols supported by the RS-485 connection; EZ7 and Modbus RTU. The protocol is selectable via DIP switch S2, located on the Main Power Board. If S2 position 1 is in the ON position, EZ7 is active. If S2 position 1 is in the OFF position, Modbus RTU* is active. S2 position 2 is not used on the Class 3200. DIP switch S2 positions 3 and 4 to select the Baud rate for the RS-485 communications. See section 6.9.3 for details on Baud rate selection. After changing the DIP switch positions, the CPU must be rebooted by pressing S1 to activate the changes.

6.7 RS-485 Wiring (continued)

* An alternate version of firmware is available that replaces Modbus RTU with BACnet MS/TP. **The meter must be ordered with this option if BACnet is desired instead of Modbus.**

There are two connection methods, daisy-chain and wire terminal, for RS-485 communications.

Daisy-Chain Method

This is the simplest method for connecting meters together.

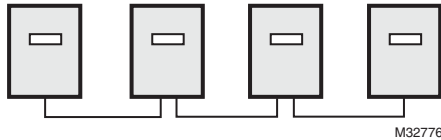

Fig. 9. Daisy-chain Configuration.

1. Connect the +(high) terminal of PORT 1 of each meter together so that the + terminals on all meters are linked, + to + to +...
2. Connect the -(low) terminal of PORT 1 of each meter together so that the - terminals on all meters are linked, - to - to -...
3. Connect the GND terminals of PORT 1 to meter 1 ONLY. The GND terminals should not be linked to each meter.
4. Torque screws to 2.2 in-lb.

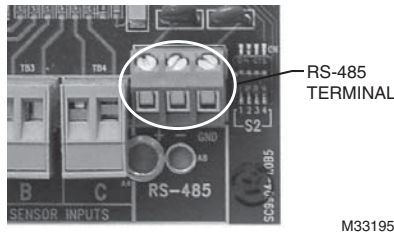

Fig. 10. RS-485 Terminal.

6.7 RS-485 Wiring (continued)

6.7.1 RS-485 Bias Resistors

When interfacing the Class 3200 meter to certain RS-485 communication equipment, it may be necessary to add bias resistance to the circuit. If this is required, there is a 2-position DIP switch on the meter's door mounted (display) circuit board. With both positions in the "ON" position, bias resistance is added to the RS-485 circuit. When both positions are in the "OFF" position, no bias is added to the RS-485 circuit.

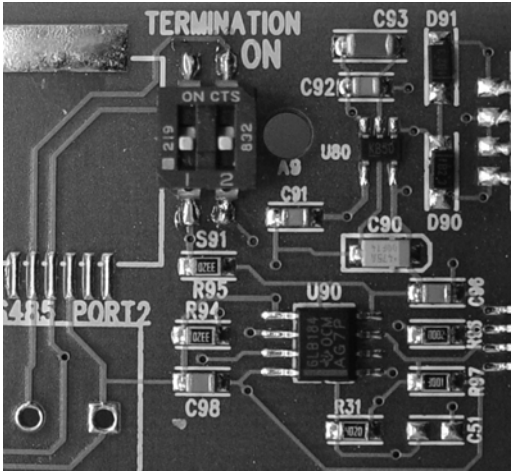

Fig. 11. Bias Resistors DIP Switch.

After performing these steps, all of the meters will be connected in a daisy chain configuration. This network of meters can then be connected to the RS-485 network and communication can be established.

Local Computer

A local computer installed in the building can communicate with the RS-485 network utilizing E-Mon's RS-232 conversion key. The RS-232 key is connected to the RS-485 terminals in the closest meter using a cable with an RJ-11 plug terminating the end that is plugged into the key and is open wiring on the other end for attachment to the meter's 3-screw RS-485 terminal block.

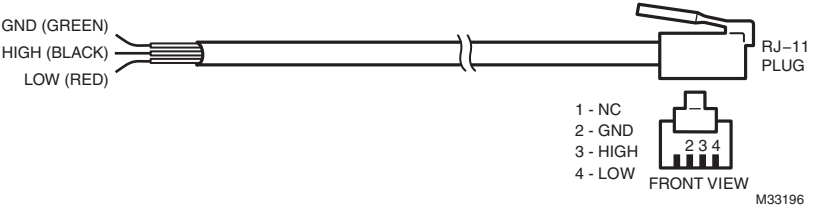

Fig. 12. RS-485 Wiring.

6.8 RS-232 Communications

6.8.1 Hardwired System using the RS-232 Communication Key

The RS-232 communications key allows you to connect Class 3200 meters to a personal computer that has the E-Mon Energy™ software installed. The computer communicates with the meters through the RS-232 key.

The RS-232 key must be located within 15 feet of the host computer.

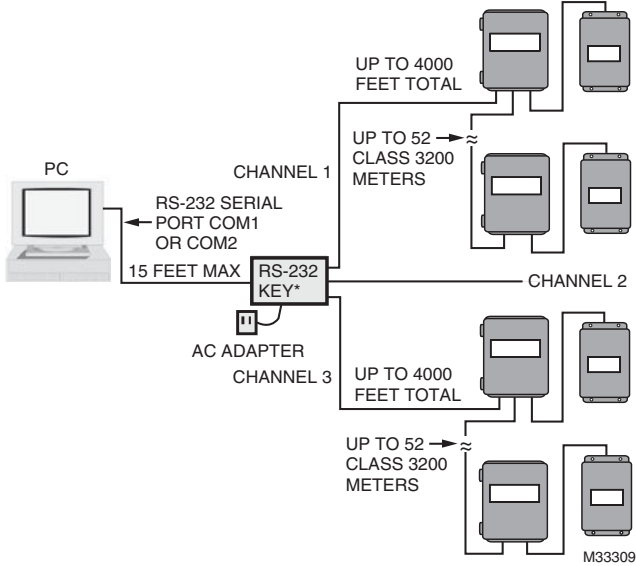

Fig. 13. RS-232 Configuration.

6.8.2 Connecting the RS-232 Key to the Computer

The RS-232 key is supplied with:

- (1) 8-conductor cable fitted with RJ-45 plugs
- (1) DB-9 serial COM port adapter
- (1) AC adapter that converts 120VAC to 9VDC for powering the RS-232 key

Connection Steps:

1. Connect the 8-conductor cable to the left-side jack (labeled “RS232”) on the rear panel of the RS-232 key.
2. Connect the appropriate COM port adapter (DB-9) to the serial port on the back of the computer. Plug the 8-conductor cable from the RS-232 key into the COM port adapter.

6.8.2 Connecting the RS-232 Key to the Computer (continued)

3. Connect the provided AC adapter into the rear panel input on the RS- 232 key. Plug the adapter into a 120VAC outlet. On the front panel of the RS-232 key, two LEDs (POWER ON and AC ON) will light up.

NOTE: When the E-Mon Energy™ software is accessed on the computer, a third LED (RS232 READY) will turn on. This indicator will light up as soon as the E-Mon Energy software is booted up and the correct COM port is set up via the settings provided in the software's Locations menu.

6.8.3 Connecting Class 3200 Meters to the RS-232 Key using RS-485

On the rear panel of the RS-232 key, there are three jacks labeled as channels A, B and C. These are RS-485 serial communications ports used to connect the meters. Each of these channels can be connected to as many as 52 individual meters over a total cable distance of 4,000 feet. The channels are independent and must not be connected to each other.

Modular Plug Method

This simple method requires using 4 stranded conductors inside a cable that is fitted with an RJ-11 type plug for 4-conductor modular systems at the key end of the cable and open conductors on the meter end.

*Do not use any pre-made telephone cables.

1. Plug the 4-wire RJ-11 cable/plug assembly into Channel A on the RS-232 key. Connect the other end of this cable to the meter via the RS-485 port at the bottom right of the Class 3200 meter main power board.

NOTE: The total combined cable length must not be more than 4000 feet.

2. Each meter has one yellow (TX) and one green (RX) LED located on the right side of meter board just below the ribbon cable. If the system is properly wired, these two LEDs will be OFF. These LEDs will flash when the computer and meter are communicating.

6.9 Modem Wiring

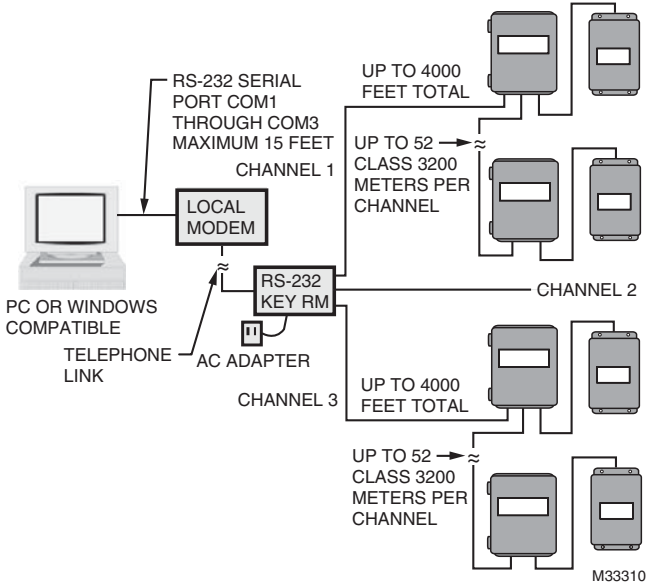

Fig. 14. Modem Configuration.

6.9.1 Modem (RS-232 KEY RM)

The RS-232 key with modem connects the entire RS-485 network of Class 3200 meters to a telephone line.

** Refer to Section 6.7 for RS-485 network connections.

On the back panel of the RS-232 key/modem, the left jack (RS232) is not used in most cases since there is no local host computer.

The two jacks at the top center of the rear panel on the RS-232 key/modem are for connecting the phone line. Connect either one of these two jacks to the telephone line.

IMPORTANT:

The telephone line should be dedicated exclusively to the automatic meter reading system. Never connect to a telephone line used by other modems or fax machines. If there are telephones connected to this phone line, the proprietor must be aware that all phones must be on "hook" in order for the modem to work. A dedicated phone line is suggested for system reliability.

6.9.2 External Modem

1. All meters should be connected to the RS-232 key as described in 6.8.2.
2. DISCONNECT POWER TO THE RS-232 KEY. Remove the cover by removing the 2 screws from the bottom of the enclosure.
3. On the circuit board, locate the blue jumpers J7 (MODEM) and J8 (ex-MODEM). If these jumpers are set in the DIRECT position, you must move the jumpers so they are set in the MODEM position. Replace the cover and secure the enclosure.
4. Connect the RS-232 key to the external modem using the supplied 8-conductor flat modular cable.
5. Connect the 9VDC adapter to the power input on the back of the RS-232 key and plug it into a 120VAC outlet.

IMPORTANT:

The modem should use a phone line that is dedicated exclusively to the AMR system. Do not use a phone line that is shared by another modem or fax machine.

6.9.3 Baud Rate Selection

The communication Baud rate on the Class 3200 meter is set through positions 3 and 4 on DIP switch S2 on the meter circuit board. The default is 9600 Baud.

1. Select 9600 when using the Class 3200 meter with a modem.
2. The Baud rate on the meter must always match the Baud rate selected in the E-Mon Energy software; otherwise, communications will not function.
3. After a Baud change, press the CPU reset button to register the change.
4. All meters in the daisy-chain circuit must be set at the same Baud rate.

3	4	BAUD RATE
ON	ON	9600
OFF	ON	19200
ON	OFF	38400
OFF	OFF	76800

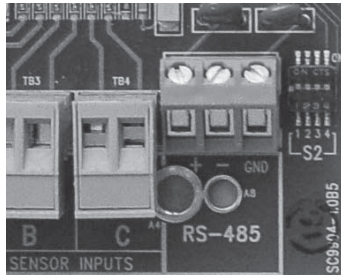

M33195

Fig. 15. Baud Rates.

6.10 Modbus RTU Wiring

The Class 3200 Modbus option meter communicates with building automation equipment over a 2-wire (3-conductor) RS-485 network using Modbus RTU protocol. The meters are networked in a daisy-chain configuration with BELDEN 1120A cable or equivalent required. The cable rating of 600V allows the RS-485 network to be connected to 480-volt meters. Up to 52 meters can be installed on a network string. The maximum combined length of all daisy-chained cables must not exceed 4000 feet.

The meter-to-network connection is through the 3-screw terminal which is located on the Main Power Board of the meter. Tighten the terminals to 2.2 in-lb.

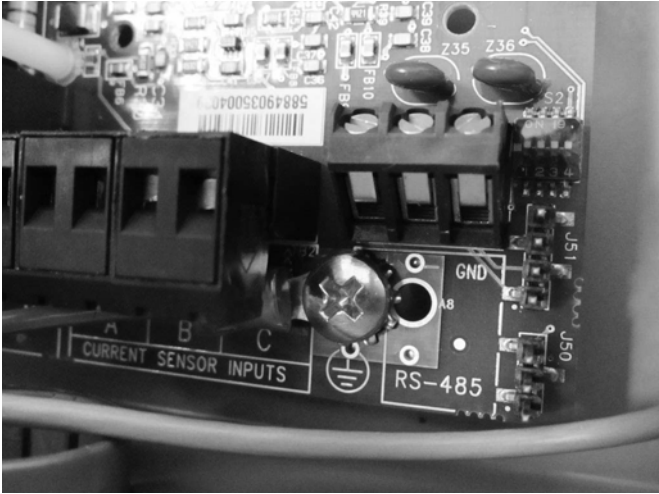

Fig. 16. RS-485 Terminal.

The meter is shipped with a Modbus ID number of 02. NOTE: Modbus address must be changed to 01 for open protocol for BACnet (Optional) to function as specified. This must be changed if the network has more than one meter installed. The change must be done before the meter is introduced into the network. The meter can be numbered from 1 to 247. There can be no duplicate numbers on a network, so caution must be taken when assigning a meter ID number prior to its installation on the RS-485 network.

6.11 BACnet MS/TP Wiring

BACnet MS/TP wiring is the same as Modbus and EZ7 wiring. See Sections 10 and 11 for instructions on changing I.D. and IP addresses.

6.12 Connecting Class 3200 Meters to USB Key using RS485

The USB Key plugs into the PC's USB port and provides a termination point for the RS485 wiring from the meters. Up to 52 meters can be "Daisy chained" with up to 4000 feet total RS485 wiring. The USB Key is labeled for "plus (+)", "minus (-)", and ground and the wiring must match the same positions on the meters. If more than 52 meters are to be monitored, additional USB Keys can be utilized to connect them to the PC.

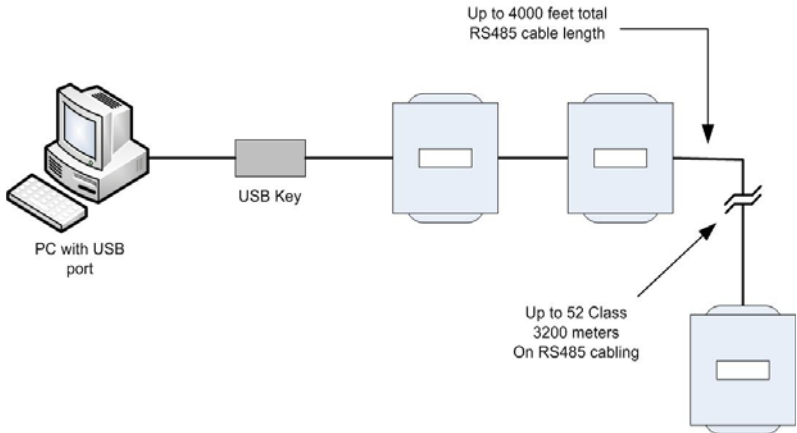

Fig. 17. Connecting Class 3200 Meters to the USB Key using RS485.

6.13 Ethernet Communications

Ethernet communications connections are available through an optional EKM-E key, which converts the meter's RS-485 output to an ethernet connection. The key provides data only with the EZ-7 protocol and is not designed to support Modbus or BACnet.

NOTE: The meter is not designed to connect directly through an Ethernet connection, but must utilize an appropriate RS485/Ethernet converter module/modem.

Class 3200 Ethernet/IP Addressable meters can be tied into a local Ethernet network individually, or a single Ethernet-connected meter can communicate with multiple RS-485 daisy-chained conventional (EZ-7) class 3200 meters using a single IP address. Each device (EKM-E) that is connected directly to the ethernet network requires a unique IP address. With a public IP address, the system can be addressed with E-Mon Energy software through the internet for remote reading capabilities.

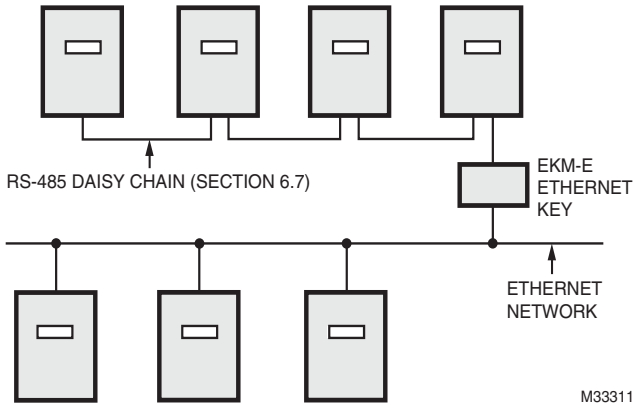

Fig. 18. Ethernet Communications.

7.0 MULTIPLE-LOAD MONITORING

The E-Mon D-Mon Class 3200 meter provides extreme flexibility by allowing additional sets of current sensors to be used in parallel so multiple load locations can be monitored by one meter. This feature allows a totalized display readout from two or more load circuits.

You may use parallel sensors to monitor specific breakers from one panel, specific breakers from more than one panel, two or more complete panels, etc.

When paralleling current sensors, the following rules must be followed for accurate readings:

1. Current sensors must be installed in complete sets of three, with a maximum of three sensors installed in parallel per phase.
2. All sensors used in parallel must be of the same amperage rating (all 100-amp, all 400-amp, etc.) The rating is determined by the current rating of the meter. For example, a 200-amp meter must use extra sets of 200-amp current sensors.
3. All locations being monitored must have the same power source. A 480-volt meter cannot monitor a 208-volt load, nor can a meter monitor two-480 volt loads if they are from different originating power sources or from different transformers.
4. Multiply the meter display readings by the number of sets of current sensors installed. Example: Meter readings of 5 kWh with 2 sets of current sensors - 10 kWh is the actual usage. ($5 \times 2=10$.)

7.0 MULTIPLE-LOAD MONITORING (CONTINUED)

NOTE: One set of current sensors equates to three sensors, one per phase. The multiplier only applies when extra sets of current sensors are installed on one meter. If you are using only one set of three current sensors, the multiplier is not required.

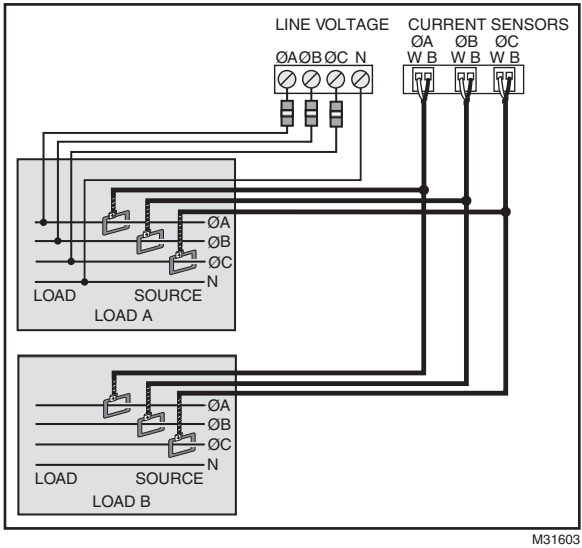

Fig. 19. Multiple-load Wiring Diagram.

8.0 PREVENTATIVE/SCHEDULED MAINTENANCE

The unit is shipped in a calibrated and fully functional tested condition. Since the unit is factory-calibrated using proprietary firmware algorithms, no internal unit adjustments are necessary.

This unit contains no internal adjustments, so no preventative or scheduled maintenance is required.

No cleaning or decontamination procedures are required for this instrument.

9.0 LITHIUM BATTERY REPLACEMENT

The Class 3200 meter has a lithium coin cell battery, which is used to retain the contents of SRAM and the RTC during power outages. The battery's life expectancy is greater than 5 years.

Nominal Working Voltage	3 Vdc Output
Nominal Current Capacity	225 mAHr
Cell Chemical	Manganese Dioxide Lithium
Operating Temperature Range	-30 to +60 Degrees Celsius
Manufacturer	Panasonic
Manufacturer's Part Number	CR2032

Table 1. Battery specifications at 25 degrees Celsius.

WARNING

Replace battery with Panasonic part number CR2032 only. Use of another battery may present a risk of fire or explosion. See owner's manual for safety instructions.

The battery cell is mounted in a coin cell holder on the upper right side of the main power board. The internal unit firmware will set a flag to indicate the low battery condition. When the unit data is next downloaded, the monitoring facility will be alerted of the low battery condition and will schedule a service call.

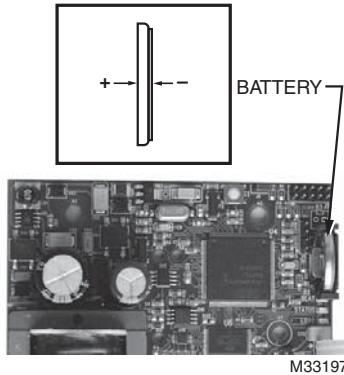

Fig. 20. Lithium Battery Cell.

CAUTION

Battery may explode if mistreated. Do Not recharge, disassemble, or dispose of in fire.

9.0 LITHIUM BATTERY REPLACEMENT (CONTINUED)

Use the following procedure to replace the lithium battery cell.



CAUTION

The battery is not completely discharged; therefore, **DO NOT** short the terminals on the battery with any conductive material.



CAUTION

Internal circuit card components are extremely sensitive to electrostatic discharge. Be careful not to touch internal circuitry prior to discharging any static buildup on your person. To discharge yourself, touch a grounded metal object such as conduit or a metal enclosure interior.

1. Disconnect power from the meter at the unit external circuit breaker.
2. Remove the battery from its holder and place on a non-conductive surface.
3. Install new battery into the PCB battery holder.

NOTE: Care should be taken to ensure that the replacement battery is installed with the same polarity as the battery that was removed. No damage to the unit or battery will occur if battery is inadvertently installed in the wrong polarity.

4. Dispose of the used battery in accordance with the manufacturer's (Panasonic's) instructions.

10.0 CLASS 3200 METER OPERATING MODES

The E-Mon D-Mon[®] Class 3200 meter is used to monitor electric power usage of individual loads after the utility meter and store kW and KVAR data for automatic meter reading.



Fig. 21. Class 3200 Stand Alone Meter with 4 Line Display.

10.1 Start Up Screens

When the meter starts up, the screen displays firmware image type. CL3200 and M, After approximately 4 seconds, the screen displays active configurations: EZ7 ID, Meter configurations – phase, voltage, amperage, Calibration factors or serial number, Date/time and firmware version.

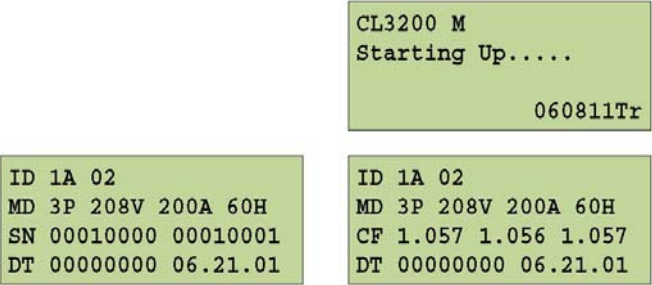

Fig. 22. Start Up Screens.

10.2 Normal Mode Display Screens

The Class 3200 meter features seven Normal Mode Display Screens for monitoring the meter. Each screen is displayed for 5 second intervals, before scrolling onto the next screen.

You can “lock” the scrolling display on any one of the seven screens. This will be explained in detail on following pages.

Explanations of the Normal Mode Display Screens are as follows:

Screen 1: Total Kilowatt-Hours (kWh) Delivered	<table border="1"> <tbody> <tr> <td>TOTAL :</td> <td>123 KWH</td> </tr> <tr> <td></td> <td style="text-align: right;">></td> </tr> </tbody> </table>	TOTAL :	123 KWH		>		
TOTAL :	123 KWH						
	>						
Screen 2: Peak Demand (kW) with Date & Time Stamp	<table border="1"> <tbody> <tr> <td>KW PEAK:</td> <td>25.5 KW</td> </tr> <tr> <td>ON DATE:</td> <td>05/15</td> </tr> <tr> <td>AT TIME:</td> <td>11:45</td> </tr> </tbody> </table>	KW PEAK:	25.5 KW	ON DATE:	05/15	AT TIME:	11:45
KW PEAK:	25.5 KW						
ON DATE:	05/15						
AT TIME:	11:45						
Screen 3: Actual Load (kW) with Present Time	<table border="1"> <tbody> <tr> <td>LOAD:</td> <td>24.0 KW</td> </tr> <tr> <td>DATE:</td> <td>06/14/11</td> </tr> <tr> <td>TIME:</td> <td>08:46:58</td> </tr> </tbody> </table>	LOAD:	24.0 KW	DATE:	06/14/11	TIME:	08:46:58
LOAD:	24.0 KW						
DATE:	06/14/11						
TIME:	08:46:58						
Screen 4: Average Current (amps) Per Phase	<table border="1"> <tbody> <tr> <td>PH-A:</td> <td>12.3 AMPS</td> </tr> <tr> <td>PH-B:</td> <td>10.2 AMPS</td> </tr> <tr> <td>PH-C:</td> <td>14.7 AMPS</td> </tr> </tbody> </table>	PH-A:	12.3 AMPS	PH-B:	10.2 AMPS	PH-C:	14.7 AMPS
PH-A:	12.3 AMPS						
PH-B:	10.2 AMPS						
PH-C:	14.7 AMPS						
Screen 5: Average Voltage (volts) Per Phase	<table border="1"> <tbody> <tr> <td>PH-A:</td> <td>119.8 VOLTS</td> </tr> <tr> <td>PH-B:</td> <td>120.2 VOLTS</td> </tr> <tr> <td>PH-C:</td> <td>119.5 VOLTS</td> </tr> </tbody> </table>	PH-A:	119.8 VOLTS	PH-B:	120.2 VOLTS	PH-C:	119.5 VOLTS
PH-A:	119.8 VOLTS						
PH-B:	120.2 VOLTS						
PH-C:	119.5 VOLTS						
Screen 6: Average Voltage (volts) Phase to Phase	<table border="1"> <tbody> <tr> <td>P-AB:</td> <td>0.0 VOLTS</td> </tr> <tr> <td>P-BC:</td> <td>0.0 VOLTS</td> </tr> <tr> <td>P-CA:</td> <td>0.0 VOLTS</td> </tr> </tbody> </table>	P-AB:	0.0 VOLTS	P-BC:	0.0 VOLTS	P-CA:	0.0 VOLTS
P-AB:	0.0 VOLTS						
P-BC:	0.0 VOLTS						
P-CA:	0.0 VOLTS						
Screen 7: Power Factor (pf) Per Phase	<table border="1"> <tbody> <tr> <td>PH-A:</td> <td>0.0 % PF</td> </tr> <tr> <td>PH-B:</td> <td>0.0 % PF</td> </tr> <tr> <td>PH-C:</td> <td>0.0 % PF</td> </tr> </tbody> </table>	PH-A:	0.0 % PF	PH-B:	0.0 % PF	PH-C:	0.0 % PF
PH-A:	0.0 % PF						
PH-B:	0.0 % PF						
PH-C:	0.0 % PF						

Fig. 23. Class 3200 Meter Display Screens.

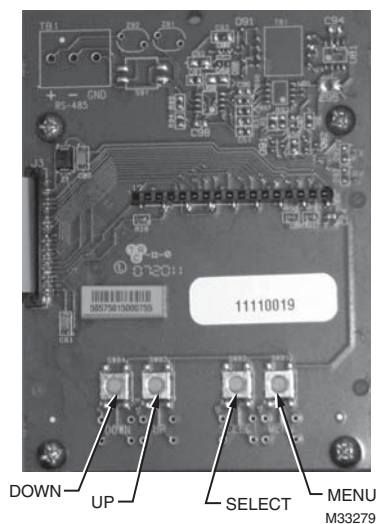

Fig. 24. Push Buttons.

10.3 How to Program the Display Screens

The display information can be programmed using four push buttons switches. The push buttons (DOWN, UP, SELECT, MENU) are located at the bottom of the display board on the inside front door of the meter. The buttons are used to program the following:

- Date & Time (This field sets the month, day, year, and time.)
- Device ID (This field changes the default setting, which is 1A for EZ7 and 1 for ModBus.)
- Reset KW/KWH Read (This field resets the Peak kW Demand to zero.)

10.3.1 Date & Time

To change the date and time, complete the following steps:

1. Press the MENU button.
2. The following screen will appear:

Date & Time
Device ID
Reset KW/KWH Read
Exit

3. Press the SELECT button. The date and time screen will appear, and the 2 digit month will be blinking.

DATE: 02-16-2012
TIME: 01:57:36

4. Use UP or DOWN button to make changes, press SEL button to advance to the next field. Press MENU button to return to main menu.
5. If changes were made, you'll be asked to save, press UP or DOWN to select Y or N; press SEL to proceed returning to main menu. In main menu, select EXIT to get out of programming mode and return to normal display mode.

10.3.2 Device I.D.

To change Device I.D., complete the following steps:

1. Press the MENU button.
2. The following screen will appear:

Date & Time
Device ID
Reset KW/KWH Read
Exit

3. Use the UP and DOWN buttons to select the Device ID line. Press the SELECT button. The Device I.D. screen will appear.

EZ7 ID:	1A
MODBUS ID:	2

4. Use UP or DOWN button to make changes, press SEL button to advance to the next field. Press MENU button to return to main menu.

Save Change? Y

5. If changes were made, you'll be asked to save, press UP or DOWN to select Y or N; press SEL to proceed returning to main menu. In main menu, select EXIT to get out of programming mode and return to normal display mode.

10.3.3 Peak Demand Reset

To reset the recorded peak kW demand, complete the following steps:

1. Press the MENU button until “Reset kW/kWh Read” is indicated by the arrow on the display.

Date & Time
Device ID
Reset KW/KWH Read
Exit

2. Press the SELECT button. The following screen will appear on the display.

Reset kW only? N
Reset all? N

3. Press the UP button to change the N to a Y after “Reset kW only?”.
4. The peak demand will be reset to zero and the meter will return to its normal scrolling display mode.

10.3.4 Display Hold Feature

You can “lock” the scrolling display so that it will stay locked on any one of the seven screens.

To stop the display from scrolling, complete the following steps:

1. Press the UP and DOWN buttons to choose which of the six screens you would like to display.
2. Press the Select button. At the top of the display, you will see the message HOLD1. This will lock the display for 1 HOUR.

NOTE: The display hold feature has different selectable time periods.

3. Pressing Select again will show the message HOLD6. This will lock the display for 6 HOURS.
4. Continuing to press the Select button will provide additional timing choices:
HOLD12: Locks the display for 12 HOURS
HOLD24: Locks the display for 24 HOURS
HOLD: Locks the display indefinitely

To exit the HOLD mode:

Press the Select button as many times as needed until the HOLD message disappears from the display.

** Be sure to exit from the HOLD mode when you are done using this feature.

11.0 HIGH VOLTAGE METERING

kWh Meter Installation Instructions for Use with E-MON Meters in High Voltage Applications

The E-MON model # E34-12025HV kWh meter is designed to be used for monitoring high voltage (2400, 4160, 13200, etc) circuits, either “stand alone” or in an AMR application.

This meter is intended to be used with the appropriate high voltage Potential Transformers (PTs) and Current Transformers (CTs) supplied by others. The meter application is centered around a 120 VAC secondary output from the high voltage PTs and a 5 amp secondary output from the high voltage CTs.

Items addressed by this document include the installation of the E34-12025HV kWh meter on high voltage circuits as well as the calculations to provide the correct meter multiplier based on the PT and CT sizes used on the high voltage conductors.

Installation should be performed by qualified personnel and only according to all applicable electrical codes.

High Voltage CTs (supplied by others) reduce the primary current (amps) to a directly proportional 0~5 amp secondary output. As an example, a 0~400 amp primary becomes a 0~5 amp proportional signal from the secondary output. In our application, the high voltage CT secondary is installed as a continuous “loop”, with a single conductor connected to both secondary terminals.

To convert the 0~5 amp signal to a 0~ 2 volt signal, E-MON's Current Sensors are installed on the CT secondary conductor. A set of 25 amp sensors is used in this application. These sensors have the high voltage CT secondary conductor passed through them five (5) times (see below) by looping the secondary conductor as shown in the drawing. The reason for this is so that the 5 amp secondary now appears to the current sensor as a 0~25 amp signal. This creates a conversion of the CT's primary current to a directly proportional 0~ 2 volt signal which is utilized by the E-MON meter. The example from the first paragraph has now become a 400 amp to 2 volt device, by this technique.

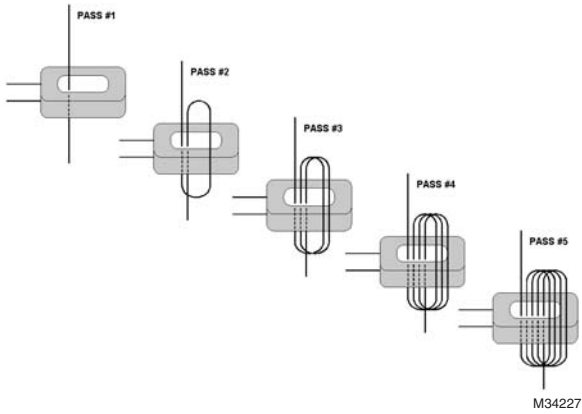

Fig. 25. High Voltage CT's.

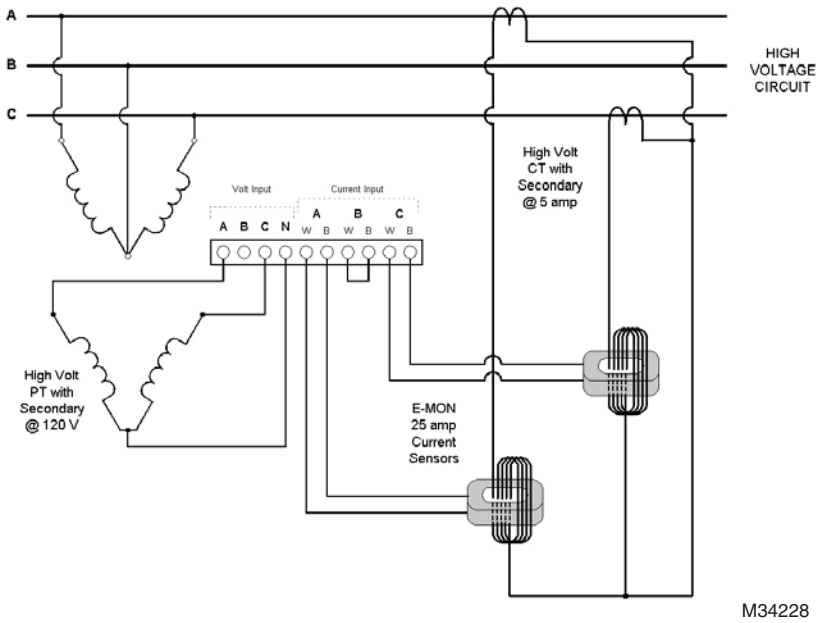

Fig. 26. Wiring Diagram For 3-wire High Voltage Circuits.

This special high voltage meter installation shows the correct wiring procedure for 4-wire high voltage circuits. In this application, the 3 element meter connection is used on the secondary circuits of the user supplied high voltage PTs and CTs.

The E-MON meter used in this application is the model E34-12025HV kWh meter.

Installation of these meters requires the use of three (3) current sensors mounted on the secondaries of the high voltage Current Transformers. See the drawing above for proper wiring. For correct operation, the meter must be installed correctly.

This special high voltage meter installation utilizes high voltage PTs (Potential Transformers) and CTs (Current Transformers) supplied by others. The E-MON meter is installed using the secondary outputs of these devices.

High voltage PTs reduce the primary voltage (4160v, 13200v, etc.) to a Secondary output of 120v. This secondary is connected to the E-MON meter voltage inputs as shown in the wiring diagram. High voltage CTs reduce the primary current (amps) to a directly proportional 0~5 amp output. As an example, a 0~400 amp primary becomes a 0~5 amp proportional signal from the secondary output. This allows much smaller wiring to be utilized in the meter hookup. The high voltage CT secondary is installed as a continuous "loop", with a single lead connected to both secondary terminals.

E-MON meters accept a 0~2 volt signal from their Current Sensors. To convert the 0~5 amp signal, the Current Sensors are installed on the CT secondary lead. A set of 25 amp sensors is used in this application. These sensors have the high voltage CT secondary lead passed through them five (5) times by looping the wire as shown in the drawing. This allows a direct conversion of the CTs primary current to a directly proportional 0~2 volt signal, which is used by the meter.

Since there is a signal ratio introduced by the high voltage CTs and PTs, it will be necessary to multiply the number on the meter's display for a correct reading. The meter multiplier is calculated by using the CT ratio and the PT Ratio. [PTR x CTr / Number of Secondary Lead Passes Through Sensor]. The E-MON 25 amp HV kWh meter with 5 wraps of the high voltage CT secondary will have its multiplier calculated by the formula shown below.

EXAMPLE:	CT = 400:5 = 80:1 (CTr = 80)
	PT = 4200:120 = 35:1 (PTR = 35)
	Wraps (Passes) = 5
	<i>METER MULTIPLIER</i> = PTR x (CTr/Wraps)
	35 x (80/5)
	35 x (16) = 560

12.0 CLASS 3200 PROTOCOL DEFINITIONS

ModBus Customer Point Map: CL3200					
Address	Registers	Format	Description	Units	CL 3200
40001 ¹	2	Integer	Energy delivered	Wh Pulse	R/W
40001 ¹	2	Integer	Energy received	Wh Pulse	R/W
40005 ¹	2	Integer	Reactive energy delivered	VARh Pulse	R/W
40007 ¹	2	Integer	Reactive energy received	VARh Pulse	R/W
41001 ¹	2	Float	Energy delivered	kWh	R/W
41003 ¹	2	Float	Energy received	kWh	R/W
41005 ¹	2	Float	Reactive energy delivered	kVARh	R/W
41007 ¹	2	Float	Reactive energy received	kVARh	R/W
41009	2	Float	Real power	kW	R
41011	2	Float	Reactive power	kVAR	R
41013	2	Float	Apparent power	kVA	R
41015	2	Float	Power factor	% PF	R
41017	2	Float	Peak demand	kW	R
41019	2	Float	Current average	Amps	R
41021	2	Float	Voltage line-neutral	Volts-N	R
41023	2	Float	Voltage line-line	Volts-L	R
41025	2	Float	Frequency	Hz	R
41027	2	Float	Phase angle	Degree	R
41029	2	Float	Real power, phase A	kW	R
41031	2	Float	Real power, phase B	kW	R

ModBus Customer Point Map: CL3200					
Address	Registers	Format	Description	Units	CL 3200
41033	2	Float	Real power, phase C	kW	R
41035	2	Float	Reactive power, phase A	kVAR	R
41037	2	Float	Reactive power, phase B	kVAR	R
41039	2	Float	Reactive power, phase C	kVAR	R
41041	2	Float	Apparent power, phase A	kVA	R
41043	2	Float	Apparent power, phase B	kVA	R
41045	2	Float	Apparent power, phase C	kVA	R
41047	2	Float	Power factor, phase A	% PF	R
41049	2	Float	Power factor, phase B	% PF	R
41051	2	Float	Power factor, phase C	% PF	R
41053	2	Float	Current, phase A	Amps	R
41055	2	Float	Current, phase B	Amps	R
41057	2	Float	Current, phase C	Amps	R
41059	2	Float	Voltage, line to neutral, phase A-N	Volts-N	R
41061	2	Float	Voltage, line to neutral, phase B-N	Volts-N	R
41063	2	Float	Voltage, line to neutral, phase C-N	Volts-N	R
41065	2	Float	Voltage, line to line, phase A-B	Volts-L	R
41067	2	Float	Voltage, line to line, phase B-C	Volts-L	R
41069	2	Float	Voltage, line to line, phase C-A	Volts-L	R
41071	2	Float	Phase angle, phase A	Degree	R
41073	2	Float	Phase angle, phase B	Degree	R

ModBus Customer Point Map: CL3200					
Address	Registers	Format	Description	Units	CL 3200
41075	2	Float	Phase angle, phase C	Degree	R
41083 ²	2	Float	External Input 1	Pulse	R/W
41085 ²	2	Float	External Input 2	Pulse	R/W
44001 ³	6	Custom	Interval Day Block		R/W
44007 ⁴	1 per interval	Integer	Interval Data	Pulse	R
45501 ⁵	2 per day	Custom	Interval Data Headers		R
46025 ⁶	8	Custom	RTC Date/Time		R/W
46049 ⁷	8	Custom	EZ7 ID, ModBus ID, Serial Number		R/W
46057	8	Custom	Recorder Info., Demand Interval		R/W
46513	8	Custom	Flags L1: Power Failure, Battery		R
46521	8	Custom	Flags L2: Power Failure Date		R
<p>1. To clear single meter kWh/kVARh, set multiple points at 40001 or 41001 for 8 points with data set to 0000 0000 0000 0000 0000 0000 0000 0000.</p>					
<p>2. External inputs are standard on Class 5000 meters and optional on Class 3400 meters (Part of Expanded Feature Package).</p>					
<p>To clear external inputs, set multiple points at 41083 or 41085 for 2 points with data set to 0000 0000. Jumper J6 must be closed.</p>					
<p>3. To set the interval data day block, set multiple points at 44001 for 6 points with data set to 0C0I 0000 MMDD YYYY 0000 0000.</p>					
<p>0C = Channel, 0I = Interval (0F = 15 minute intervals, 05 = 5 minute intervals)</p>					
<p>4. Each register represents a 15 or 5 minute kWh pulse value based on the interval day block. 96 registers max with 15 minute intervals. 288 registers max with 5 minute intervals. The first interval data register 44007 represents the pulse count for the first 15 or 5 minute interval beginning at midnight.</p>					
<p>5. The interval data headers represent days with available interval data. Each day represents 2 registers. Format: MMDD YYYY.</p>					
<p>6. To set the date and time, set multiple points at 46025 for 4 points with data set to HHMM SSDW MMDD YYYY (DW=day of week)</p>					
<p>7. To change the ModBus ID, set single point at 46050 with data set to new ModBus ID (e.g. 1 to 247). Jumper J6 must be closed.</p>					

BACnet Object Descriptors: CL3200

Instance ID	BACnet Object	Description	Units	BACnet Property	CL 3200
1 ¹	Analog Input	Energy delivered	kWh	Present Value	R
2 ¹	Analog Input	Energy received	kWh	Present Value	R
3 ¹	Analog Input	Reactive energy delivered	kVARh	Present Value	R
4 ¹	Analog Input	Reactive energy received	kVARh	Present Value	R
5	Analog Input	Real power	kW	Present Value	R
6	Analog Input	Reactive power	kVAR	Present Value	R
7	Analog Input	Apparent power	kVA	Present Value	R
8	Analog Input	Power factor	% PF	Present Value	R
9	Analog Input	Peak demand	kW	Present Value	R
10	Analog Input	Current average	Amps	Present Value	R
11	Analog Input	Voltage line-neutral	Volts-N	Present Value	R
12	Analog Input	Voltage line-line	Volts-L	Present Value	R
13	Analog Input	Frequency	Hz	Present Value	R
14	Analog Input	Phase angle	Degree	Present Value	R
15	Analog Input	Real power phase A	kW	Present Value	R
16	Analog Input	Real power phase B	kW	Present Value	R
17	Analog Input	Real power phase C	kW	Present Value	R
18	Analog Input	Reactive power phase A	kVAR	Present Value	R
19	Analog Input	Reactive power phase B	kVAR	Present Value	R

BACnet Object Descriptors: CL3200

Instance ID	BACnet Object	Description	Units	BACnet Property	CL 3200
20	Analog Input	Reactive power phase C	kVAR	Present Value	R
21	Analog Input	Apparent power phase A	kVA	Present Value	R
22	Analog Input	Apparent power phase B	kVA	Present Value	R
23	Analog Input	Apparent power phase C	kVA	Present Value	R
24	Analog Input	Power factor phase A	% PF	Present Value	R
25	Analog Input	Power factor phase B	% PF	Present Value	R
26	Analog Input	Power factor phase C	% PF	Present Value	R
27	Analog Input	Current phase A	Amps	Present Value	R
28	Analog Input	Current phase B	Amps	Present Value	R
29	Analog Input	Current phase C	Amps	Present Value	R
30	Analog Input	Voltage line-neutral phase A-N	Volts-N	Present Value	R
31	Analog Input	Voltage line-neutral phase B-N	Volts-N	Present Value	R
32	Analog Input	Voltage line-neutral phase C-N	Volts-N	Present Value	R
33	Analog Input	Voltage line-line phase A-B	Volts-L	Present Value	R
34	Analog Input	Voltage line-line phase B-C	Volts-L	Present Value	R
35	Analog Input	Voltage line-line phase C-A	Volts-L	Present Value	R
36	Analog Input	Phase angle phase A	Degree	Present Value	R
37	Analog Input	Phase angle phase B	Degree	Present Value	R
38	Analog Input	Phase angle phase C	Degree	Present Value	R

BACnet Object Descriptors: CL3200

Instance ID	BACnet Object	Description	Units	BACnet Property	CL 3200
39	Analog Input	Reserve A	No units	Present Value	R
40	Analog Input	Reserve B	No units	Present Value	R
41	Analog Input	Reserve C	No units	Present Value	R
42 ²	Analog Input	External Input 1	Pulse	Present Value	
43 ²	Analog Input	External Input 2	Pulse	Present Value	

1. To clear single meter kWh/kVARh, select reset kW/kWh on the display menu of the meter. This function will also reset external inputs. Jumper J6 must be closed.

2. External inputs are standard on Class 5000 meters and optional on Class 3400 meters (Part of Expanded Feature Package). To clear external inputs, select reset kW/kWh on the display menu of the meter. This function will also reset kW/kVARh. Jumper J6 must be closed.

Instance ID	BACnet Object	BACnet Property	CL3200
BACnet Device ID	Device	Object identifier	R
BACnet Device ID	Device	Object name	R
BACnet Device ID	Device	Object type	R
BACnet Device ID	Device	System status	R/W
BACnet Device ID	Device	Vendor name	R
BACnet Device ID	Device	Vendor Identifier	R
BACnet Device ID	Device	Model name	R
BACnet Device ID	Device	Firmware revision	R
BACnet Device ID	Device	Application software version	R
BACnet Device ID	Device	Location	R/W
BACnet Device ID	Device	Description	R/W
BACnet Device ID	Device	Protocol version	R
BACnet Device ID	Device	Protocol services supported	R
BACnet Device ID	Device	Protocol object types supported	R
BACnet Device ID	Device	Protocol revision	R
BACnet Device ID	Device	Object list	R
BACnet Device ID	Device	Max APDU length supported	R
BACnet Device ID	Device	Segmentation supported	R
BACnet Device ID	Device	Local time	R
BACnet Device ID	Device	Local date	R
BACnet Device ID	Device	APDU time out	R/W
BACnet Device ID	Device	Number of APDU retries	R/W
BACnet Device ID	Device	Device address binding	R

13.0 LIMITED METER WARRANTY

Subject to the exclusions listed below, E-Mon will either repair or replace (at its option) any product that it manufactures and which contains a defect in material or workmanship.

The following exclusions apply:

1. This Limited Warranty is only effective for a period of (5) five years following the date of manufacture when installed in accordance with manufacturer's instructions by qualified personnel.
2. E-Mon must be notified of the defect within ninety (90) days after the defect becomes apparent or known.
3. Buyer's remedies shall be limited to repair or replacement of the product or component which failed to conform to E-mon's express warranty set forth above.
4. Buyer shall be responsible for all freight costs and shall bear all risk of loss or damage to returned goods while in transit.
5. This Limited Warranty does not cover installation, removal, reinstallation, or labor costs, and excludes normal wear and tear. Buyer shall provide labor for the removal of the defective component or item and installation of its replacement at no charge to E-Mon.
6. This Limited Warranty does not cover any product if: (i) a product is altered or modified from its original manufactured condition, (ii) any repairs, alterations or other work has been performed by Buyer or others on such item, other than work performed with E-Mon's authorization and according to its approved procedures; (iii) the alleged defect is a result of abuse, misuse, improper maintenance, improper installation, accident or the negligence of any party; (iv) damaged as a result of events beyond E-Mon's control or other force majeure events or (v) used in conjunction with equipment, components, accessories, parts or materials not supplied or approved by E-Mon.
7. This Limited Warranty is limited to the obligation to repair or replace the manufactured product. This is the sole and exclusive remedy for any breach of warranty. IN NO EVENT SHALL E-MON BE LIABLE FOR ANY INDIRECT, INCIDENTAL, SPECIAL, CONSEQUENTIAL OR PUNITIVE DAMAGES (INCLUDING ANY DAMAGE FOR LOST PROFITS) ARISING OUT OF OR IN CONNECTION WITH THE FURNISHING OF PRODUCTS, PARTS OR SERVICES, OR THE PERFORMANCE, USE OF, OR INABILITY TO USE ANY PRODUCTS, PARTS OR SERVICES, SALE OF OR OTHERWISE, WHETHER BASED IN CONTRACT, WARRANTY, TORT, INCLUDING WITHOUT LIMITATION, NEGLIGENCE, OR ANY OTHER LEGAL OR EQUITABLE THEORY.
8. EXCEPT AS EXPRESSLY PROVIDED HEREIN, E-MON MAKES NO WARRANTY OF ANY KIND, EXPRESS OR IMPLIED WITH RESPECT TO ANY PRODUCTS, PARTS OR SERVICES PROVIDED BY E-MON INCLUDING, BUT NOT LIMITED TO, THE IMPLIED WARRANTIES OF MERCHANTABILITY AND FITNESS FOR A PARTICULAR PURPOSE. PRODUCTS OR COMPONENTS DISTRIBUTED, BUT NOT MANUFACTURED, BY E-MON ARE NOT WARRANTED BY E-MON AND BUYER MUST INSTEAD RELY ON THE REPRESENTATIONS AND WARRANTIES, IF ANY, PROVIDED DIRECTLY TO THE BUYER BY THE MANUFACTURER OF SUCH PRODUCT OR COMPONENT.

99 Washington Street
Melrose, MA 02176
800.517.8431
TestEquipmentDepot.com

© U.S. Registered Trademark
© 2012 E-Mon
62-0390-02 JPG Rev. 11-12
Printed in United States

E-Mon[®]
Energy Monitoring Products