

OPTIMIZER UNITARY CONTROLLER

Honeywell Unitary Controllers provide flexible, freely programmable, demand-led control that delivers tangible benefits to reduce energy spending while driving new levels of functionality and efficiency in today's buildings.

These new controllers offer BACnet™ IP, BACnet™ T1L, or BACnet™ MS/TP as their backbone communication protocol and Sylk™, Modbus RTU as embedded integration protocols, flexible universal input/output (UIOs), power relays, and solid-state relays (SSRs).

They offer performance-based engineering with Niagara 4 and enable Single-Tool-Engineering throughout the whole Building Management System with cost-effective installation.

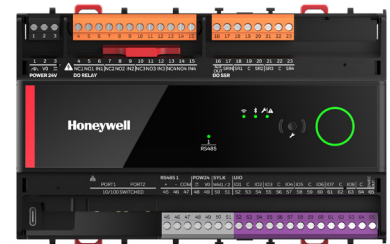

Honeywell Unitary Controllers are available in large and small housing options.

FEATURES AND HIGHLIGHTS

SIMPLE AND FLEXIBLE ENGINEERING

- UIOs configurable as analog input, binary input, binary output, and analog output.
- High inrush current relays.
- Solid-state relays with increased current support compared to standard Triac outputs.
- Sylk™ bus two-wire polarity insensitive interface connects to Honeywell Sylk™ wall modules without hardware I/O.
- Modbus RTU for integration.
- Daisy chain ethernet connection ensures reliable data speed over greater distance.
- Engineering tools including function block library and sample application templates ensuring a consistent experience from the room, plant controllers, and supervisor.

EFFICIENCY AND SAFETY ON SITE

- Easy to install into fuse box (DIN43880) or on DIN rail, surface mount.
- Optional terminal covers for protection, thereby eliminating the need for cabinet enclosures.
- Color-coded, removable terminal blocks to simplify wiring and replacement.
- Live debugging and fast differential download for application changes to limit downtime to a minimum.
- Power failure detection and data recovery.

EASY UPGRADE TO IP

- RJ45 and twisted pair T1L available as IP communication standards.
- Increased network speeds compared to traditional building automation systems.
- Support of standard BMS and IT protocols, such as BACnet™, offering an open system for interconnectivity.
- Possibility to reuse installed wiring as T1L uses two-core twisted pair cables with screw terminals.
- Honeywell T1L devices support daisy chains with distances between devices of up to 984 ft. (300 m), way above the 328 ft. (100 m) limit of standard RJ45 ethernet and allowing greater wiring lengths.

CONTROLLER PART NUMBERS DESCRIPTION

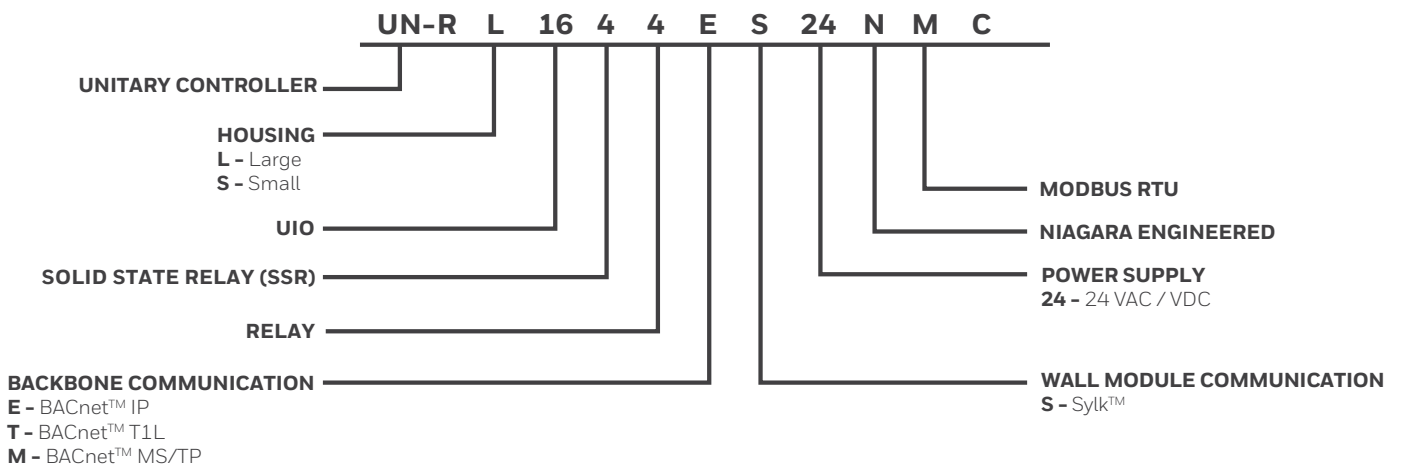

PART NUMBERS

UNITARY CONTROLLER PART NUMBERS							
PART NUMBER	HOUSING	UNIVERSAL IO	SOLID STATE RELAY (SSR)	RELAY	COMMUNICATION	SYLK™ BUS	
UN-RS0844ES24NMC	Small	8	4	4	BACnet™ IP	Yes	
UN-RS0844MS24NMC	Small	8	4	4	BACnet™ MS/TP	Yes	
UN-RS0844TS24NMC	Small	8	4	4	BACnet™ T1L	Yes	
UN-RL1644ES24NMC	Large	16	4	4	BACnet™ IP	Yes	
UN-RL1644MS24NMC	Large	16	4	4	BACnet™ MS/TP	Yes	
UN-RL1644TS24NMC	Large	16	4	4	BACnet™ T1L	Yes	

ACCESSORIES OR REPLACEMENT PARTS	
PART NUMBER	DESCRIPTION
CW-Cov-L-Unitary	Terminal cover for the L-version of the unitary controller (sold in pack of 10)
CW-Cov-S-Unitary	Terminal cover for the S-version of the unitary controller (sold in pack of 10)
10BASE-T1L-ADAPT	IP-T1L single pair media adapter that allows converting 10BASE-T traffic to 10BASE-T1L
SCRW-TB-UNI-L	Kit of screw terminals for Unitary controller
IO-JUMPER-4-10	4-pin relay Jumper Bar to connect 4 relay IN terminals (sold in pack of 10)

DIMENSIONS AND WEIGHTS

LARGE HOUSING

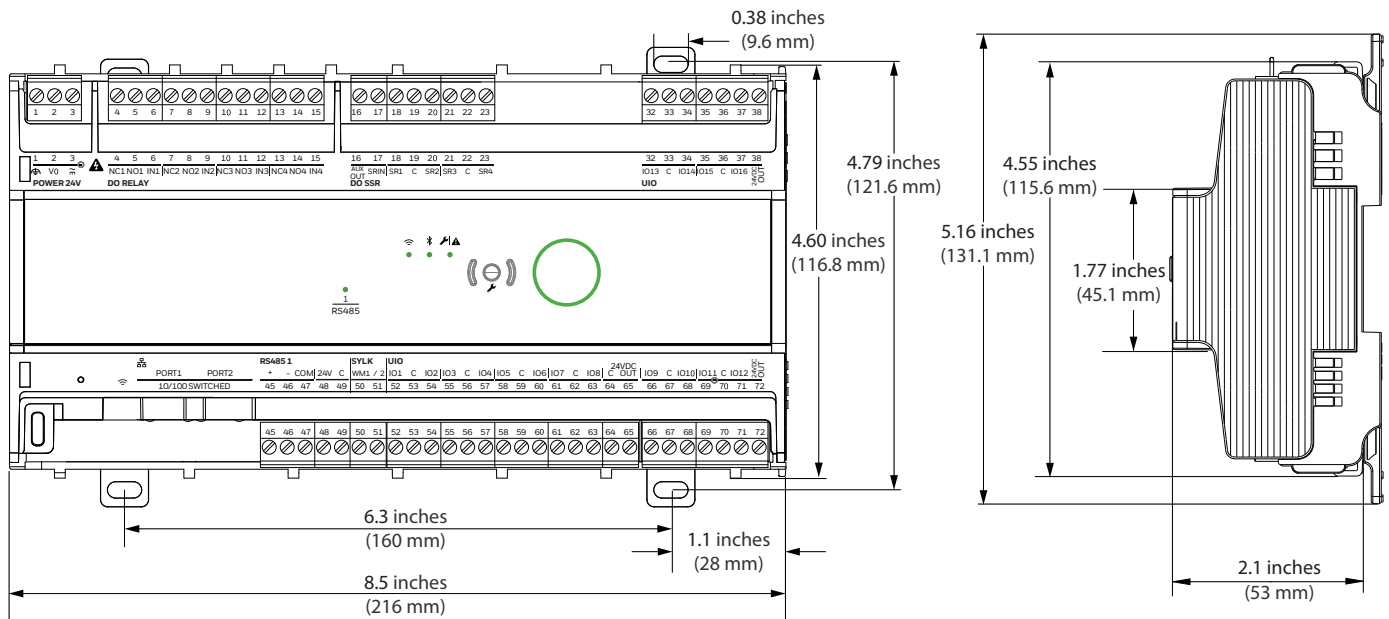

SMALL HOUSING

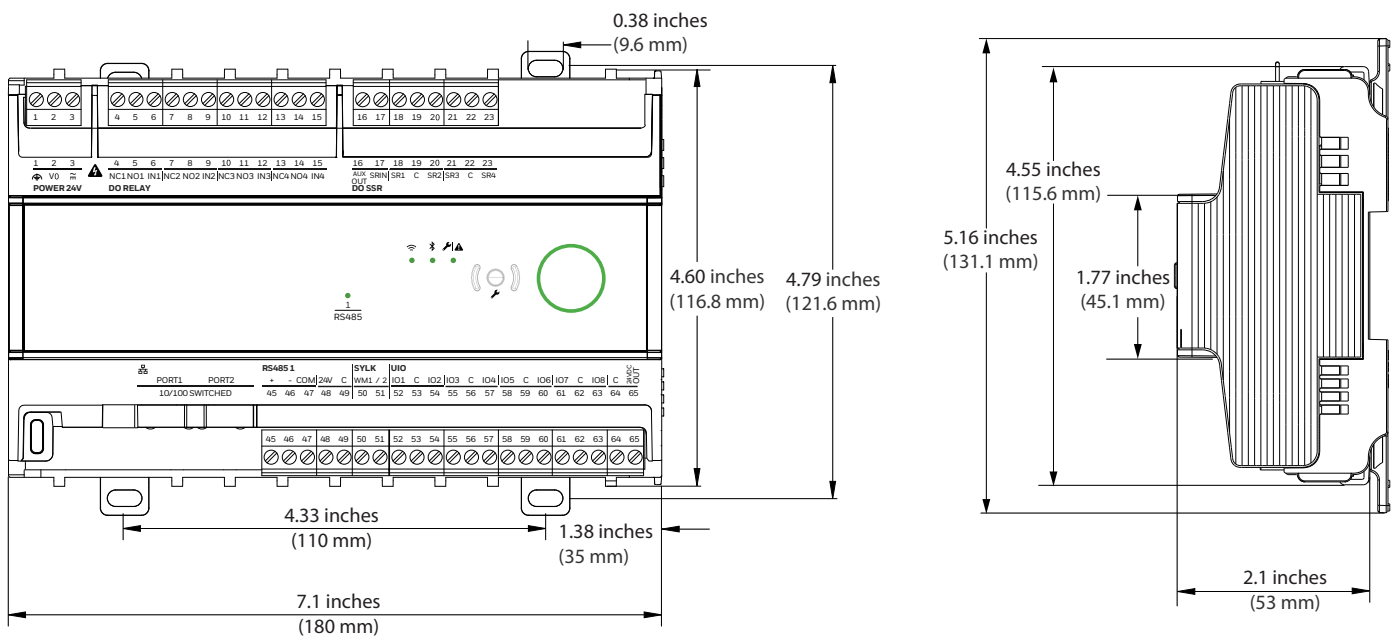

All dimensions are in inches (mm).

WEIGHT AND DIMENSIONS	
PARAMETER	SPECIFICATION
Dimension (L x W x H)	Large - 8.5 x 4.79 x 2.1 inches (216 x 121.6 x 53 mm) Small - 7.1 x 4.7 x 2.1 inches (180 x 121.6 x 53 mm)
Weight	Large - 1.256 lbs. (570 grams) Small - 1.064 lbs. (483 grams)
Mounting	Mounting in fuse boxes (DIN43880), on DIN rails or surface mounted with optional protection covers.

HARDWARE OVERVIEW

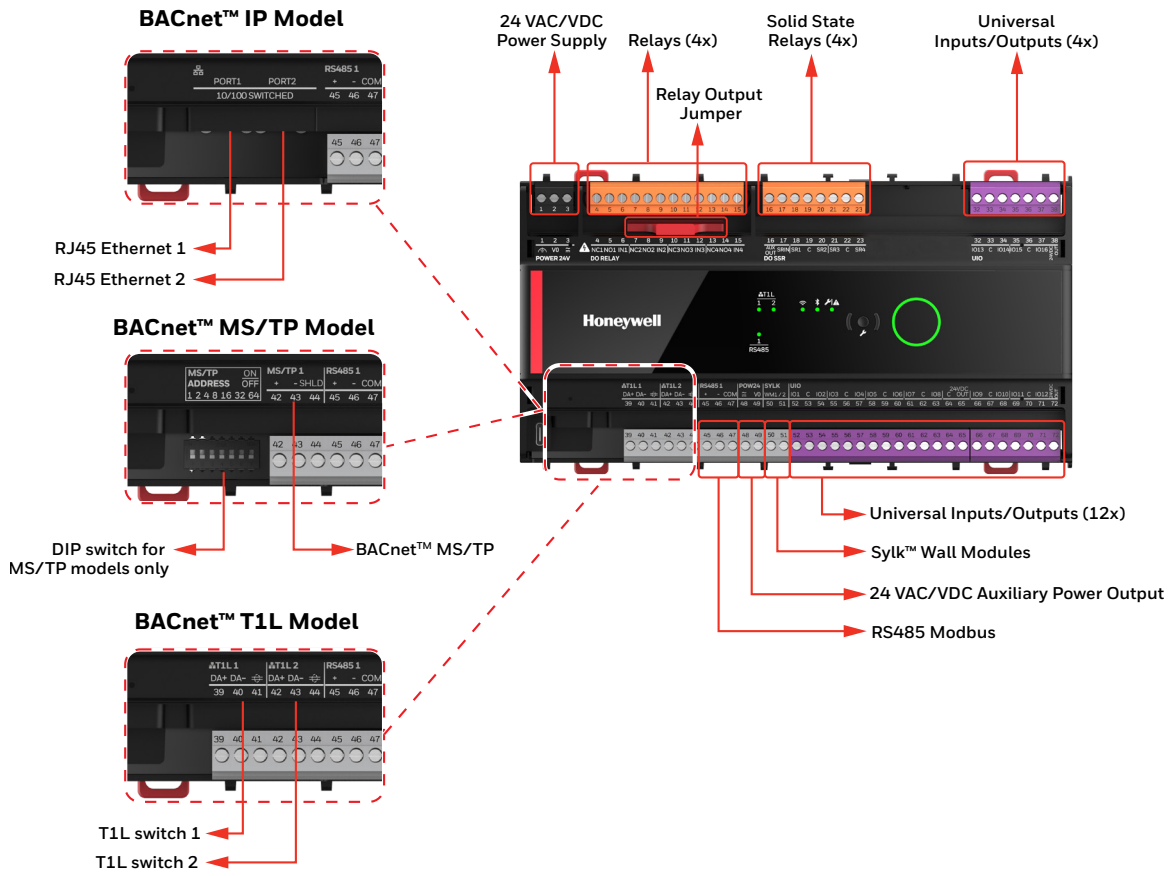

SYSTEM OVERVIEW

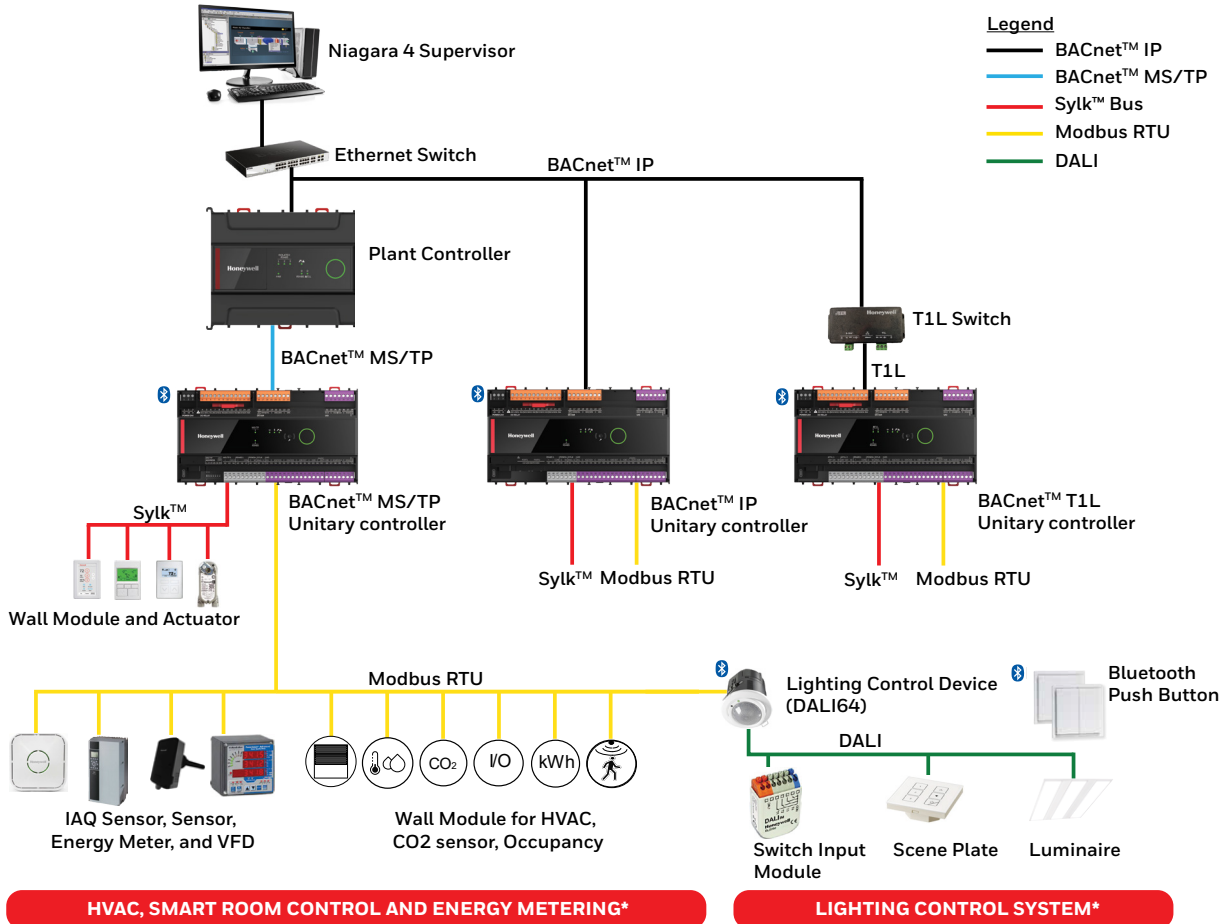

* Devices subject to local availability. Contact your local sales representative for information on available devices in your region.

PRODUCT SPECIFICATION

HARDWARE	
PARAMETER	SPECIFICATION
CPU	Crossover processor NXP I.MRT, Cortex M7
Memory capacity	16 MB QSPI Flash, 16 MB SDRAM
Ethernet	BACnet™ IP: 2 x RJ-45 Ethernet ports with a protection that allows loop topology to continue the communication with other controllers even if one node fails, when used with an RSTP supporting device.
Real Time Clock	24 hours backup after power failure After 24 hours, the time will reset to factory default time until the user performs a BACnet™ Time Sync
Small LEDs	Transmission or reception of communication signal (green)
Large LED	Controller status (Green, Yellow, and Red)

ELECTRICAL	
PARAMETER	SPECIFICATION
Rated Input Voltage	20 - 30 VAC / 24 - 30 VDC
Nominal Power Consumption	<ul style="list-style-type: none"> BACnet™ IP : 4 VA BACnet™ MS/TP : 4 VA BACnet™ T1L : 4 VA
Full Load Power Consumption (Maximum load including external loads, Sylk™, Communication, Universal IO output, and 24 VDC output, excluding the load on the SSRs and Relays). Note: For the current consumption of SSR, refer SSR section table.	<ul style="list-style-type: none"> BACnet™ IP : 30 VA BACnet™ MS/TP : 30 VA BACnet™ T1L : 30 VA
Frequency Range	50 - 60 Hz
Auxiliary Power Output	1 x 24 VAC at 75 mA 1 x 24 VDC at 75 mA
Impulse Voltage	330 VAC

OPERATIONAL ENVIRONMENT	
PARAMETER	SPECIFICATION
Storage Temperature	-40 °F to 150 °F (-40 °C to 66 °C)
Operating Temperature	-40 °F to 122 °F (-40 °C to 50 °C)
Humidity	5 % to 95 % RH., non-condensing
Protection	IP20, NEMA 1
Pollution Level	2

SUPPORTED DEVICES*	
Sylk™ Wall Modules	TR40, TR40-H, TR40-CO2, TR40-H-CO2, TR42, TR42-H, TR42-CO2, TR42-H-CO2, TR50 (emulation mode only), TR71, TR71-H, TR75, TR75-H, TR75-HE, TR120 (TR75-E), and TR120-H (emulation mode only).
Sylk™ Sensor	C7400S
Sylk™ Actuators	MS3103, MS3105, MS3110, and MS3120
Non Sylk™ Actuators	MS4103, MS4105, MS7403, MS7405, MS7503, MS7505, MS8103, and MS8105
Hardwired Wall Modules	T7460 A, B, C, D, E, F and T7770 A, B, C, D, E, F, G
Modbus Devices	Modbus RTU devices from any manufacturer (including Honeywell Modbus devices, for example DALI64MODPSUF/S, TR50, and TR80) can be used.

* Devices subject to local availability. Contact your local sales representative for information on available devices in your region.

SOLID STATE RELAY (SSR)
SSR works with maximum 24 VAC / VDC
1.5 A constant; 3.5 A inrush for 0.1 seconds per SSR output.
Factory installed jumper between 24 VAC or 24 VDC supply and SSR input shared by all SSRs.

RELAYS
Up to 277 VAC / 230 VAC (+20 %)
3 contacts per relay (Normally open (NO), Normally closed (NC), Common (IN)).
10 A constant current on normally open contact and 100 A inrush for 100 ms.
Total current across all relays is limited to 12 A if all commons are connected via a relay jumper.

PRODUCT SPECIFICATION

UNIVERSAL IO	
PARAMETER	SPECIFICATION
AI	16-bit A/D resolution
UI	<ul style="list-style-type: none"> 0(2)...10 V direct/reverse or 0(4)...20 mA input. Sensors: 10K Ohm NTC Type II, 10K Ohm NTC Type III, 10K3A1, 20K Ohm NTC, PT100, PT1000, NI1000TK5000, NI1000 Class B DIN43760, PT3000, 100 Ohm to 100K Ohm resistive (custom characteristic). Hardwired wall modules*: space temperature, space temperature setpoint, fan speed override, occupancy mode override. Dry contact binary input with direct/reverse. Pulse input with maximum frequency 100 Hz, minimum pulse width 5 ms. Compatible with the S0* interface for pulse counters.
AO	<ul style="list-style-type: none"> Voltage output with 0(2)...11 V direct/reverse with -3 mA ...+20 mA. Current output with 0(4)...20 mA direct/reverse. Hardwired wall modules*: LED Control.
DO	Dry contact binary output with direct/reverse.

* Devices subject to local availability. Contact your local sales representative for information on available devices in your region.

COMMUNICATION	
PARAMETER	SPECIFICATION
Protocol supported	<ul style="list-style-type: none"> BACnet™ IP (RJ45 or T1L) BACnet™ MS/TP* Modbus RTU (Modbus client only)
IP Addressing Modes	<ul style="list-style-type: none"> Dynamic: DHCP and Link-local Static: Assigned
Sylk™	2-wire, polarity-insensitive
* Auto Baud rate detection is provided for the BACnet™ MS/TP controllers.	

T1L COMMUNICATION	
PARAMETER	SPECIFICATION
10BASE-T1L Standard	802.3cg-2019
Connection	Screw terminal, auto MDI-X
Cable Type	Single twisted pair, 18AWG, shielded or unshielded
Distance	Maximum 984 ft. (300 m) to Honeywell T1L controller in daisy chain. Maximum 2,952 ft. (900 m) to any other T1L device without a daisy chain.
Transmission speed	10 Mbps

STANDARDS AND APPROVALS
CE mark
BACnet™ BTL®-Listed; BACnet™ Advanced Application Controller (B-AAC) certification pending, expected in 2023.
UL 916
UL/ULC 60730-1
FCC/IC Product Class B

APPLICABLE TECHNICAL LITERATURE	
TITLE	REFERENCE
Honeywell Unitary Controller 24 V - Mounting Instructions	31-00572
Honeywell Unitary Controller 24 V - Installation Instructions	31-00614



By using this Honeywell literature, you agree that Honeywell will have no liability for any damages arising out of your use or modification to, the literature. You will defend and indemnify Honeywell, its affiliates and subsidiaries, from and against any liability, cost, or damages, including attorneys' fees, arising out of, or resulting from, any modification to the literature by you.

Honeywell Building Technologies

715 Peachtree St NE
Atlanta, Georgia 30308, USA
[Honeywell Building Control](#)

Honeywell Products and Solutions

SARL, Z.A. La Pièce, 16, 1180 Rolle
Switzerland
[Honeywell Building Control](#)

@U.S. Registered Trademark
© 2023 Honeywell International Inc.
31-00613-01 | Rev.04-23

