

HE-69xx Surface-Mount Duct Humidity and Temperature Sensors Catalog Page

Description

The HE-6900 series product line delivers $\pm 3\%$ relative humidity (RH) sensing products.

The HE-69xx Series sensors combine humidity and temperature sensing in an all plastic enclosure for use inside ducts and economizer rooftop systems. These models are available with a nickel, platinum, or one of three thermistor temperature sensors.

The thermistor temperature sensors have a negative temperature coefficient, and a reference resistance of 2.252k ohms or 10.0k ohms. The nickel and platinum temperature sensors have a reference resistance of 1.0k ohms. These units can be powered with 14 to 30 VDC or 20 to 30 VAC. The output signal is 0 to 5 VDC or 0 to 10 VDC for humidity indication.

Features and Benefits

Humidity and Temperature Sensor in One Unit—Eliminates need for separate sensors; reduces installation time and cost.

Senses RH Over Full 0 to 100% Range—Accommodates a wide range of applications.

Protective Membrane—Protects sensors from contamination.

Quick-mount, 2-screw Installation—Reduces installation time.

Compact Enclosure for Mounting Inside Ducts—Designed for rooftop unit applications and retrofits; enables surface-mount installation

Application

The HE-69xx sensors provide humidity and temperature sensing inside ducts and rooftop economizers. They are suitable for use with Johnson Controls® direct-mount economizer controllers. The humidity element senses over the entire range of 0 to 100% RH and is housed in a plastic enclosure that is easy to install.

Temperature and humidity information from the HE-69xx can be used to precisely calculate enthalpy, which plays an important role in determining an energy-efficient and cost-effective economization strategy.

Duct humidity is an important factor in the overall quality of indoor air. The HE-69xx allows you to monitor and compare duct humidity with levels recommended in ASHRAE ventilation standards.

HE-69xx Surface-Mount Duct Humidity/ Temperature Sensors



Repair Information

If the HE-69xx Surface-Mount Duct Humidity/ Temperature Sensor fails to operate within its specifications, replace the unit. For a replacement sensor, contact the nearest Johnson Controls® representative.

Ordering Information

To order a HE-69 humidity and temperature sensor, contact the nearest Johnson Controls representative. Specify the product code number from Table 2 for a sensor and Table 3 for an accessory.

Not all models are available. See Table 3 for a list of available models.

Table 1: HE-69xx Surface-Mount Duct Humidity and Temperature Sensor

	Ordering Code Number	H	E	-	6	9		3		N	S	-	
Application	H = Humidity sensing												
Device Function	E = Element												
	-69												
Temperature Sensor Type	Y = 10k ohm Thermistor, Type III 1 = 1000 ohm Nickel 4 = 2.252k ohm Thermistor, $\pm 0.2^{\circ}\text{C}$ ($\pm 0.36^{\circ}\text{F}$) 5 = 1000 ohm Platinum, Class A 6 = 10k ohm Thermistor, Type II												
Humidity Sensor Accuracy	3 = $\pm 3\%$												
Output Signal	0 = 0 to 10 VDC 5 = 0 to 5 VDC proportional output												
	N												
Enclosure Style	S = Duct, surface mount, grey												
Logo	0 = Johnson Controls 2 = No logo												

HE-69xx Surface-Mount Duct Humidity and Temperature Sensors Catalog Page (Continued)

Table 2: Humidity and Temperature Sensors

Product Code Number	Temperature Sensor Type	Output Signal	Logo
HE-69130NS-0	1.0k ohm Nickel	0 to 10 VDC	Johnson Controls
HE-69135NS-0	1.0k ohm Nickel	0 to 5 VDC	Johnson Controls
HE-69435NS-0	2.252k ohm Thermistor, $\pm 0.2^{\circ}\text{C}$ ($\pm 0.36^{\circ}\text{F}$)	0 to 5 VDC	Johnson Controls
HE-69530NS-0	1000 ohm Platinum, Class A	0 to 10 VDC	Johnson Controls
HE-69630NS-0	10k ohm Thermistor, Type II	0 to 10 VDC	Johnson Controls
HE-69630NS-2	10k ohm Thermistor, Type II	0 to 10 VDC	No logo
HE-69Y35NS-0	10k ohm Thermistor, Type III	0 to 5 VDC	Johnson Controls

Table 3: Accessories

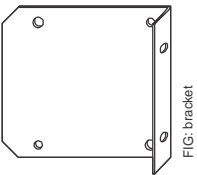
Product Code Number	Description
ACC-BRKT-100	<p>Mounting Bracket for mounting the sensor perpendicular to the duct; 3.25 H x 3.62 W x 0.75 in. D (83 x 92 x 19 mm)</p> 
ACC-CBL-100	Wiring Harness, 53 in. (1.3 m)

Technical Specifications

HE-69xx Surface-Mount Duct Humidity and Temperature Sensors (Part 1 of 2)

Power Requirements		14 to 30 VDC or 20 to 30 VAC at 50/60 Hz, Class 2
Current Draw		3 mA with no load; 25 mA maximum
Output Signal	HE-69xx0NS HE-69xx5NS	0 to 10 VDC, into 1k ohm minimum load 0 to 5 VDC, into 1k ohm minimum load
Humidity Element at 77°F (25°C)		<p>Accuracy: $\pm 3\%$ RH for 20 to 80% RH $\pm 5\%$ RH for 10 to 20% and 80 to 90% RH</p> <p>Temperature Coefficient: $\pm 0.03\%$ RH/C</p>

HE-69xx Surface-Mount Duct Humidity and Temperature Sensors Catalog Page (Continued)

HE-69xx Surface-Mount Duct Humidity and Temperature Sensors (Part 2 of 2)

Temperature Sensor	Nickel (HE-691xxNS)	Sensor type	1.0k ohm thin-film nickel
		Reference resistance	1.0k ohms at 70°F (21°C)
		Accuracy	±0.34°F at 70°F (±0.18°C at 21°C)
	2.252k ohm NTC Thermistor (HE-694xxNS)	Sensor type	2.252k ohm NTC thermistor
		Reference resistance	2.252k ohms at 77°F (25°C)
		Accuracy	±0.36°F at 77°F (±0.2°C at 25°C)
	Platinum (HE-695xxNS)	Sensor type	1.0k ohm thin-film platinum, Class F0.15 IEC60751 (Class A)
		Reference resistance	1.0k ohms at 32°F (0°C)
		Accuracy	±0.35°F at 70°F (±0.19°C at 21°C)
	10k ohm NTC Thermistor, Johnson Controls Type II (HE-696xxNS)	Sensor type	10k ohm NTC thermistor, Johnson Controls Type II
		Reference resistance	10k ohms at 77°F (25°C)
		Accuracy	±0.9°F at 70°F (±0.5°C at 25°C)
10k ohm NTC Thermistor, Johnson Controls Type III (HE-69YxxNS)	Sensor type	10k ohm NTC thermistor, Johnson Controls Type III	
	Reference resistance	10k ohms at 77°F (25°C)	
	Accuracy	±0.36°F at 77°F (±0.2°C at 25°C)	
Ambient Operating Conditions		32 to 140°F (0 to 60°C) 0 to 100% RH, 85°F (29.4°C) maximum dew point	
Survival Operating Conditions		-20 to 140°F (-29 to 60°C) 0 to 100% RH, 85°F (29.4°C) maximum dew point	
Ambient Storage Conditions		-40 to 140°F (-40 to 60°C) 0 to 100% RH, 85°F (29.4°C) maximum dew point	
Terminal Connections		1/4 in. (6.4 mm) external spade	
Acceptable Wire Gauge		16 to 24 AWG (1.3 to 0.5 mm diameter) wire (18 AWG [1.0 mm diameter] wire recommended)	
Dimensions (H x W x L)		3 x 3 x 1-1/4 in. (76 x 76 x 31 mm)	
Shipping Weight		0.50 lb (0.23 kg)	
	United States	UL Listed, CCN XAPX, File E27734; to UL 60730-1; and IEC 60730-2-13. Plenum rated (UL 2043)	
	Canada	cUL Listed, CCN XAPX7, File E27734; to CAN/CSA E60730-1; and CAN/CSA-E60730-2-13	
	Europe	CE Mark - Johnson Controls declares that this product is in compliance with the essential requirements and other relevant provisions of the EMC Directive.	
	Australia and New Zealand	RCM Mark, Australia/NZ Emissions Compliant	