

325-L SERIES

Lever Acting Design with OPDs
for 5 psi Piping Systems

Maxitrol's 325-L Series line pressure regulators with OPDs are for use on piping systems up to 5 psi. The regulator reduces pounds pressure to a level within the appliance or equipment's operating supply range. The line regulator is located upstream of equipment already fitted with an appliance regulator.



325-3L47

Specifications

- Pipe Sizes** 3/8" thru 2" threaded connections with NPT or ISO7-1 threads.
- Housing Material** All models: aluminum.
- Mounting** All models with the exception of 325-7AL210D and 325-9L210E are suitable for multi-positional mounting. 325-7AL210D and 325-9L210E are to be mounted in a horizontal upright position only. If ball check vent limiting device is installed, mount in an upright position only.
NOTE: Line pressure regulators with separate overpressure protection devices are factory preassembled and supplied to the field as a unit. All Maxitrol gas pressure regulators should be installed and operated in accordance with Maxitrol Safety Warning Instructions (see LPROPD_MI_EN.FR).
- Certifications** All models: ANSI Z21.80/CSA 6.22 Line Pressure Regulators
- Gas Types** Suitable for natural, manufactured, mixed gases, liquefied petroleum gases, and LP gas-air mixtures.
- Maximum Inlet Pressure** 5 psi (34.5 kPa)
With 12A09, 12A39, or 12A49 Vent Limiter Installed
Natural: 5 psi (34.5 kPa); LP: 2 psi (13.8 kPa)
- Minimum Inlet Pressure** 1 psi (7 kPa)
- Emergency Exposure Limits** 65 psi (450 kPa) (inlet side only)
- Maximum Individual Load/
Capacity**..... 325-3L47 (3/8", 1/2") (w/OPD 47 attached)..... 125,000 Btu/h
325-3L48 (1/2") (w/OPD 48 attached)..... 200,000 Btu/h
325-5L48 (1/2") (w/OPD 48 attached).....235,000 Btu/h
325-5L48 (3/4") (w/OPD 48 attached).....320,000 Btu/h
325-5L600 (3/4") (w/OPD 600 attached).....425,000 Btu/h
325-5L600 (1") (w/OPD 600 attached).....465,000 Btu/h
325-7AL210D (1 1/4", 1 1/2") (w/OPD 210D attached)1,250,000 Btu/h
325-9L210E (1 1/2", 2") (w/OPD210E attached).....2,250,000 Btu/h
- Ambient Temperature Ranges**..... -40 to 205°F (-40 to 96°C)
- Minimum Regulation**..... Suitable for pilot flow applications. (P) (Circle P) (0.15 CFH NG).

Capacities

Capacities expressed in CFH (m³/h) @ 0.64 sp gr gas

Model Number	Pipe Size	Outlet Pressure Set Point	Operating Inlet Pressure			
			1/2 psi (3.4 kPa)	3/4 psi (5.2 kPa)	1 psi (6.9 kPa)	5 psi (34.5 kPa)
325-3L47	3/8" x 3/8"	7" w.c.	125 (3.5)	125 (3.5)	125 (3.5)	125 (3.5)
		10" w.c.	100 (2.8)	125 (3.5)	125 (3.5)	125 (3.5)
325-3L47	1/2" x 1/2"	7" w.c.	125 (3.5)	125 (3.5)	125 (3.5)	125 (3.5)
		10" w.c.	105 (2.9)	125 (3.5)	125 (3.5)	125 (3.5)
325-3L48	1/2" x 1/2"	7" w.c.	160 (4.5)	200 (5.6)	200 (5.6)	200 (5.6)
		10" w.c.	120 (3.4)	200 (5.6)	200 (5.6)	200 (5.6)
325-5L48	1/2" x 1/2"	7" w.c.	235 (6.6)	235 (6.6)	235 (6.6)	235 (6.6)
		10" w.c.	235 (6.6)	235 (6.6)	235 (6.6)	235 (6.6)
325-5L48	3/4" x 3/4"	7" w.c.	320 (9.0)	320 (9.0)	320 (9.0)	320 (9.0)
		10" w.c.	245 (6.9)	320 (9.0)	320 (9.0)	320 (9.0)
325-5L600	3/4" x 3/4"	7" w.c.	345 (9.6)	425 (11.9)	425 (11.9)	425 (11.9)
		10" w.c.	260 (7.3)	425 (11.9)	425 (11.9)	425 (11.9)
325-5L600	1" x 1"	7" w.c.	375 (10.5)	465 (13.0)	465 (13.0)	465 (13.0)
		10" w.c.	285 (8.0)	465 (13.0)	465 (13.0)	465 (13.0)
325-7AL210D	1 1/4" x 1 1/4"	7" w.c.	815 (22.8)	1120 (31.4)	1250 (35.4)	1250 (35.4)
		10" w.c.	580 (16.2)	900 (25.2)	1100 (30.8)	1250 (35.4)
325-7AL210D	1 1/2" x 1 1/2"	7" w.c.	815 (22.8)	1120 (31.4)	1250 (35.4)	1250 (35.4)
		10" w.c.	580 (16.2)	900 (25.2)	1100 (30.8)	1250 (35.4)
325-9L210E	1 1/2" x 1 1/2"	7" w.c.	1380 (38.6)	2000 (56.0)	2250 (63.0)	2250 (63.0)
		10" w.c.	890 (24.9)	1750 (49.0)	2100 (58.8)	2250 (63.0)
325-9L210E	2" x 2"	7" w.c.	1380 (38.6)	2000 (56.0)	2250 (63.0)	2250 (63.0)
		10" w.c.	890 (24.9)	1750 (49.0)	2100 (58.8)	2250 (63.0)

NOTE: See pages 58-59 for Regulator Sizing Requirements and Examples.

Imblue Technology™: All models may be ordered with Imblue Technology™. Imblue Technology™ increases corrosion resistance and provides extra protection against the elements for regulators used in outdoor applications. Add suffix letter "B" to model number when ordering.

325-L SERIES

Lever Acting Design with OPDs
for 5 psi Piping Systems

Pressure Drop

Pressure Drop expressed in CFH (m³/h) @ 0.64 sp gr gas

Model Number	Pipe Size	Pressure Drop		
		7" w.c. (1.7 kPa)	1/2 psi (3.4 kPa)	3/4 psi (5.2 kPa)
325-3L47	3/8" x 3/8"	130 (3.6)	185 (5.2)	225 (6.3)
325-3L47	1/2" x 1/2"	135 (3.8)	195 (5.4)	235 (6.6)
325-3L48	1/2" x 1/2"	160 (4.5)	225 (6.3)	275 (7.7)
325-5L48	1/2" x 1/2"	315 (8.8)	450 (12.6)	545 (15.4)
325-5L48	3/4" x 3/4"	325 (9.1)	465 (13.0)	565 (16.0)
325-5L600	3/4" x 3/4"	345 (9.6)	490 (13.7)	595 (16.8)
325-5L600	1" x 1"	375 (10.5)	535 (15.0)	650 (18.4)
325-7AL210D	1 1/4" x 1 1/4"	800 (22.7)	1095 (31.0)	1385 (39.2)
325-7AL210D	1 1/2" x 1 1/2"	800 (22.7)	1095 (31.0)	1385 (39.2)
325-9L210E	1 1/2" x 1 1/2"	1360 (38.5)	2113 (59.8)	2557 (72.4)
325-9L210E	2" x 2"	1360 (38.5)	2113 (59.8)	2557 (72.4)

NOTE: See pages 58-59 for Regulator Sizing Requirements and Examples.

Spring Range Selection

Outlet Pressure Range (all models)

Certified Spring 7" to 11" w.c. (1.7 to 2.7 kPa)

NOTE: Please refer to pages 56-57 for complete Spring Selection Chart.

Lever Acting Design With OPD

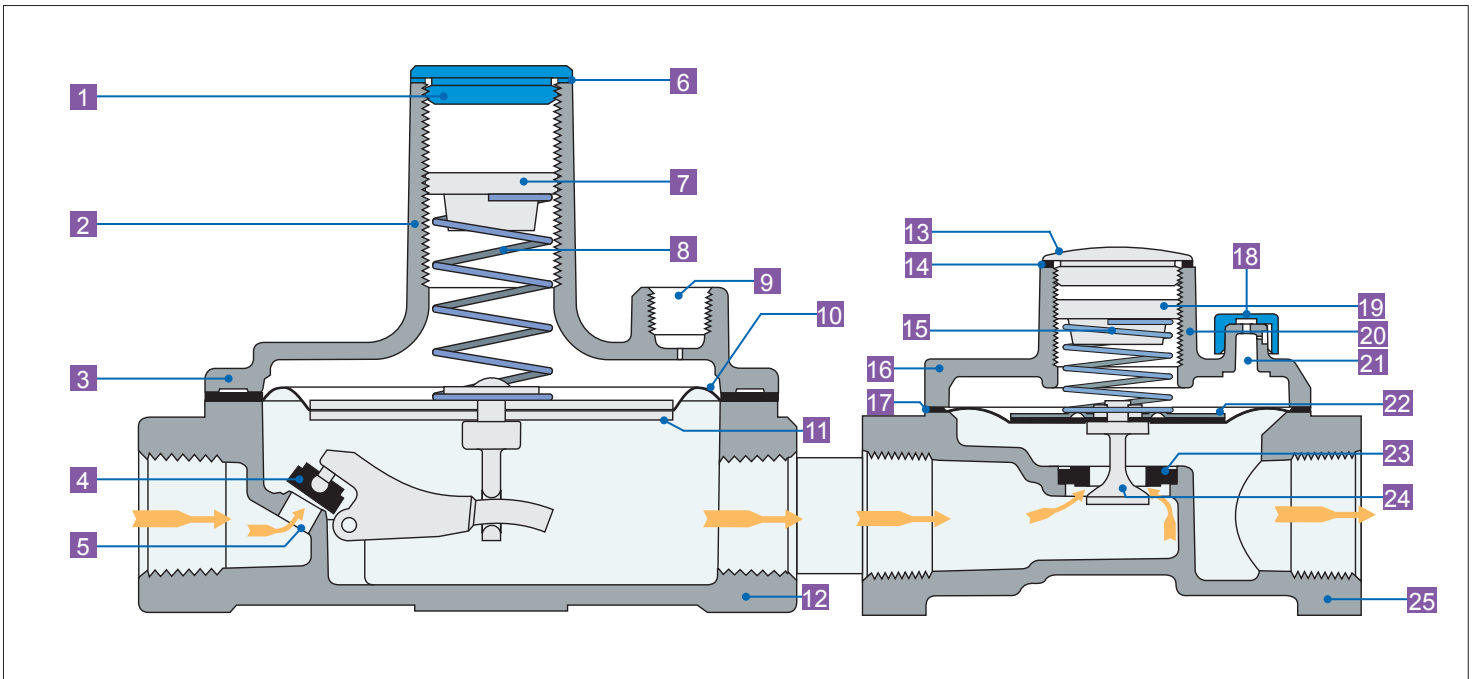

NOTE: Diagrams are graphical representations only and may differ from actual product.

1	Seal Cap	8	Spring	15	Spring	22	Diaphragm Plate
2	Stack	9	Vent Connection	16	Top Housing	23	Rubber Seat
3	Top Housing	10	Diaphragm	17	Diaphragm	24	Stem & Valve
4	Rubber Valve	11	Diaphragm Plates	18	Dust Cap	25	Bottom Housing
5	Valve Seat	12	Bottom Housing	19	Adjusting Screw		
6	Seal Cap Gasket	13	Seal Cap	20	Stack		
7	Adjusting Screw	14	Seal Cap Gasket	21	Vent		

325-L SERIES

Lever Acting Design with OPDs
for 5 psi Piping Systems

Dimensions

Model	Pipe Size	Vent Connection	Swing Radius	Dimensions		
				A	B	C
325-3L47	3/8", 1/2"	325-3L: 1/8" OPD47: Integral	3" (76 mm)	3.5" (89 mm)	8" (203 mm)	3.9" (99 mm)
325-3L48	1/2"	325-3L: 1/8" OPD48: 1/8"	3" (76 mm)	3.5" (89 mm)	8.5" (216 mm)	3.9" (99 mm)
325-5L48	1/2", 3/4"	325-5L: 3/8" OPD48: 1/8"	4.4" (112 mm)	5.3" (135 mm)	10" (254 mm)	5.4" (137 mm)
325-5L600	3/4", 1"	325-5L: 3/8" OPD600: 1/8"	4.4" (112 mm)	5.5" (140 mm)	11" (279 mm)	5.4" (137 mm)
325-7AL210D	1 1/4", 1 1/2"	325-7AL: 1/2" OPD210D: 3/8"	6.75" (171 mm)	7" (178 mm)	15.4" (391 mm)	9" (229 mm)
325-9L210E	1 1/2", 2"	325-9L: 1/2" OPD210E: 1/2"	8.3" (211 mm)	9.4" (239 mm)	20.6" (523 mm)	9.1" (231 mm)

NOTE: Dimensions are maximums and to be used only as an aid in designing clearance for the valve.
Actual production dimensions may vary somewhat from those shown.

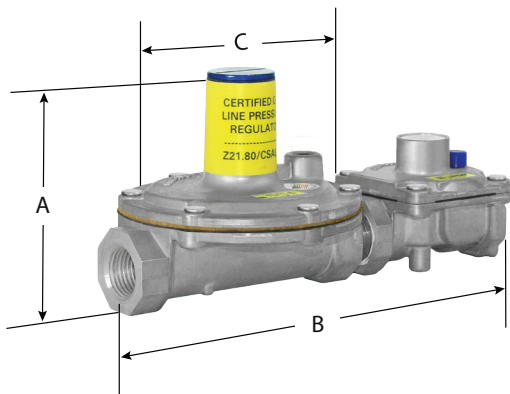

325-3L47

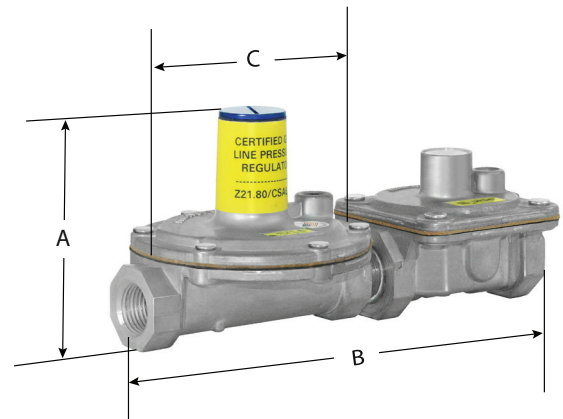

325-3L48

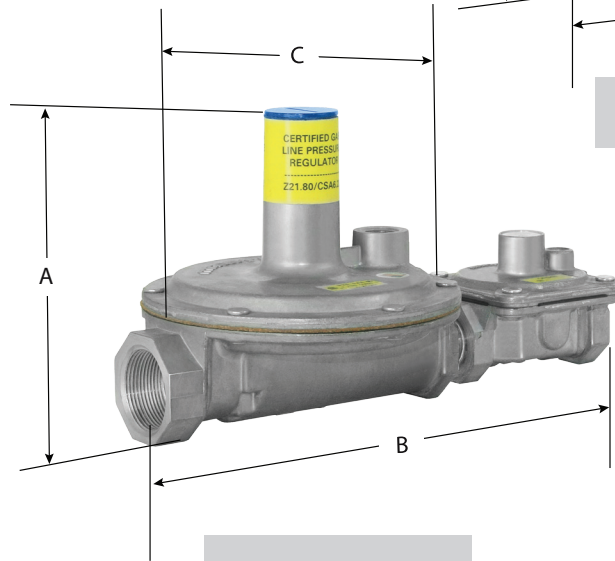

325-5L48

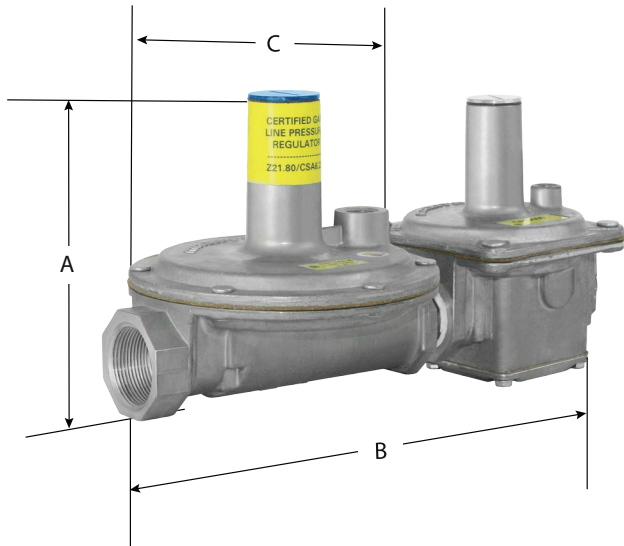
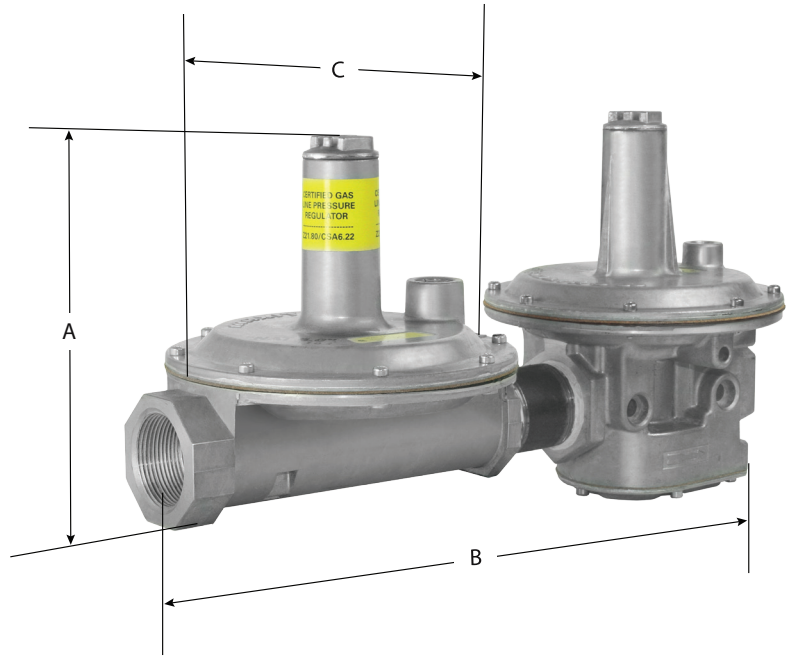
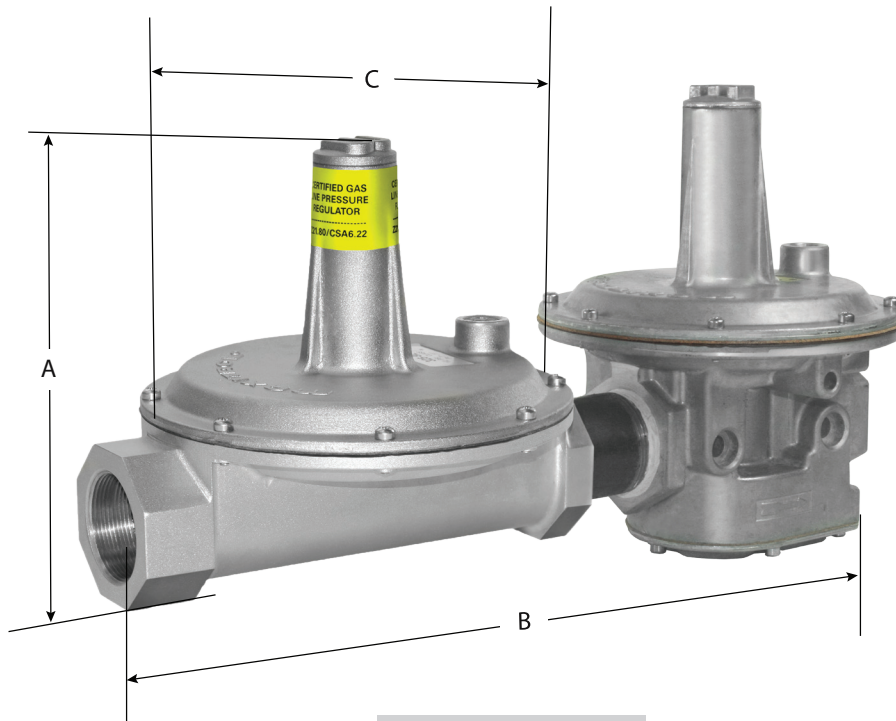
325-5L600

325-7AL210D

325-9L210E