

IB IL AO 2/U/BP-PAC

Inline, analog output terminal,
analog outputs: 2, 0 V ... 10 V, -10 V ... 10 V

Data sheet
5660_en_03

© PHOENIX CONTACT 2017-12-13

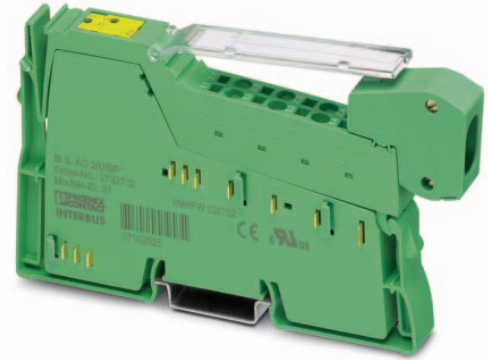

1 Description

The terminal is designed for use within an Inline station.
It is used to output analog voltage signals.

Features

- 2 analog output channels
- Connection of actuators in 2-wire technology
- Voltage ranges: 0 V ... 10 V, ± 10 V
- Output values can be represented in two different formats
- Behavior of the outputs in the event of an error can be configured
- Process data update including conversion time of the digital/analog converter < 1 ms
- Very good output driver characteristics, making it also suitable for long actuator cables



This data sheet is only valid in association with the IL SYS INST UM E user manual.



Make sure you always use the latest documentation.
It can be downloaded from the product at [phoenixcontact.net/products](https://www.phoenixcontact.net/products).

2	Table of contents	
1	Description	1
2	Table of contents	2
3	Ordering data	3
4	Technical data	3
5	Additional technical data.....	7
5.1	Tolerance and temperature response of the voltage inputs.....	7
5.2	Additional tolerances influenced by electromagnetic interference	7
5.3	Derating	8
6	Internal circuit diagram	9
7	Electrical isolation.....	9
8	Terminal point assignment.....	10
9	Connection example.....	10
10	Connection notes	10
11	Installation instructions	10
12	Connecting shielded cables via the shield plug	11
13	Local diagnostic and status indicators	12
14	Process data.....	13
14.1	OUT process data.....	13
14.2	IN process data	13
14.3	Assignment of the terminal points to the output process data	14
15	Formats for representing the output values	14
15.1	IB IL format	15
15.2	IB ST format	16
16	Output behavior	17
16.1	Output behavior during error-free operation (normal operation)	17
16.2	Behavior of the outputs in the event of an error.....	17
16.3	Output voltage behavior	17
17	Input behavior.....	18
18	Parameterization	19

3 Ordering data

Description	Type	Order No.	Pcs./Pkt.
Inline, analog output terminal, analog outputs: 2, 0 V ... 10 V, -10 V ... 10 V, connection method: 2-wire, transmission speed in the local bus: 500 kbps, degree of protection: IP20, including Inline connector and labeling field	IB IL AO 2/U/BP-PAC	2861467	1
Accessories	Type	Order No.	Pcs./Pkt.
Inline shield connector (Connector/Adapter)	IB IL SCN 6-SHIELD-TWIN	2740245	5
Connector, for digital 1, 2 or 8-channel Inline terminals (Connector/Adapter)	IB IL SCN-8	2726337	10
Inline connector, colored (Connector/Adapter)	IB IL SCN-8-CP	2727608	10
Labeling field, width: 12.2 mm (Marking)	IB IL FIELD 2	2727501	10
Insert strip, Sheet, white, unlabeled, can be labeled with: Office printing systems: Laser printer, mounting type: insert, lettering field size: 62 x 10 mm (Marking)	ESL 62X10	0809492	1
Documentation	Type	Order No.	Pcs./Pkt.
User manual, English, Automation terminals of the Inline product range	IL SYS INST UM E	-	-
Data sheet, English, INTERBUS addressing	DB GB IBS SYS ADDRESS	-	-

4 Technical data

Dimensions (nominal sizes in mm)

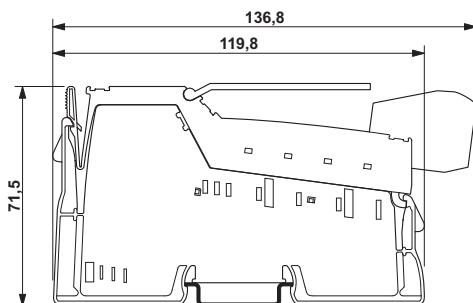

Width	12.2 mm
Height	136.8 mm
Depth	71.5 mm

General data	
Color	green
Weight	70 g (with connector)
Ambient temperature (operation)	-25 °C ... 55 °C
Ambient temperature (storage/transport)	-25 °C ... 85 °C
Permissible humidity (operation)	10 % ... 95 % (non-condensing)
Permissible humidity (storage/transport)	10 % ... 95 % (non-condensing)
Air pressure (operation)	70 kPa ... 106 kPa (up to 3000 m above sea level)
Air pressure (storage/transport)	70 kPa ... 106 kPa (up to 3000 m above sea level)
Degree of protection	IP20
Protection class	III, IEC 61140, EN 61140, VDE 0140-1
Connection data:	
Designation	Inline connector
Connection method	Spring-cage connection
Conductor cross section solid / stranded	0.08 mm ² ... 1.5 mm ² / 0.08 mm ² ... 1.5 mm ²
Conductor cross section [AWG]	28 ... 16
Stripping length	8 mm
Connection data for UL approvals	
Designation	Inline connector
Connection method	Spring-cage connection
Conductor cross section solid / stranded	0.2 mm ² ... 1.5 mm ² / 0.2 mm ² ... 1.5 mm ²
Conductor cross section [AWG]	24 ... 16
Stripping length	8 mm
Interface: Inline local bus	
Number	2
Connection method	Inline data jumper
Transmission speed	500 kbps
Transmission physics	Copper
Communications power U_L	
Supply voltage	7.5 V DC (via voltage jumper)
Current draw	typ. 33 mA max. 40 mA
Supply of analog modules U_{ANA}	
Supply voltage	24 V DC (via voltage jumper)
Supply voltage range	19.2 V DC ... 30 V DC (including all tolerances, including ripple)
Current draw	typ. 18 mA (No-load) max. 28 mA (No-load) typ. 25 mA (Full load (R _L = 2 kΩ)) max. 35 mA (Full load (R _L = 2 kΩ))

Power consumption

Power consumption	typ. 0.68 W (No-load) typ. 0.85 W (Full load ($R_L = 2 \text{ k}\Omega$))
-------------------	--

Analog outputs

Number of outputs	2 (Single-ended)
Connection technology	2-wire, shielded
Voltage output signal	0 V ... 10 V, -10 V ... 10 V
D/A conversion time	< 100 ns
Representation of output values	16 bits (15 bits + sign)
Data formats	IB IL, IB ST
Process data update	< 1 ms
Load/output load voltage output	> 2 k Ω
Precision	typ. 0.02 % (of output range final value)
Settling time	typ. 15 μs (10 % ... 90 % of final value) typ. 31 μs (0 % ... >99 % of final value)
Slew rate	typ. 0.35 V/ μs (-9.0 V ... +9.0 V, in no-load operation) typ. 0.24 V/ μs (-9.0 V ... +9.0 V, with ohmic load $R_L = 2 \text{ k}\Omega$) typ. 0.24 V/ μs (-9.0 V ... +9.0 V, with ohmic/capacitive load $R_L = 2 \text{ k}\Omega / C_L = 10 \text{ nF}$) typ. 0.09 V/ μs (-9.0 V ... +9.0 V, with ohmic/capacitive load $R_L = 2 \text{ k}\Omega / C_L = 220 \text{ nF}$)
Permissible cable length	max. 500 m (The specifications refer to nominal operation after complying with installation instructions. The specifications refer to the following reference cable type: Shielded power station cable: LiYCY; 2 x 2 x 0,5 mm ² ; VDE0812)
Transient protection of outputs	yes

Programming data (INTERBUS, local bus)

ID code (hex)	5B
ID code (dec.)	91
Length code (hex)	02
Length code (dec.)	02
Process data channel	32 Bit
Input address area	4 Byte
Output address area	4 Byte
Parameter channel (PCP)	0 Byte
Register length (bus)	32 Bit



For the programming data/configuration data of other bus systems, please refer to the corresponding electronic device data sheet (e.g., GSD, EDS).

Configuration and parameter data in a PROFIBUS system

Required parameter data	6 Byte
Need for configuration data	5 Byte

Error messages to the higher level control or computer system

Failure of or insufficient communications power U_L I/O error message sent to the bus coupler

Electrical isolation/isolation of the voltage areas**Test section****Test voltage**

7.5 V supply (bus logic), 24 V supply U_{ANA} / I/O 500 V AC, 50 Hz, 1 min.

7.5 V supply (bus logic), 24 V supply U_{ANA} /functional earth ground 500 V AC, 50 Hz, 1 min.

24 V supply (I/O) / functional earth ground of encoder supply 500 V AC, 50 Hz, 1 min.

Approvals

For the latest approvals, please visit phoenixcontact.net/products.

5 Additional technical data

5.1 Tolerance and temperature response of the voltage inputs

The tolerance values refer to the output range final value of 10 V.

Absolute tolerance	Typical	Maximum
Tolerance at 23°C		
Total offset voltage	±0.5 mV	±4 mV
Tolerance through gain	±2.5 mV	±6 mV
Differential non-linearity	±1.3 mV	±3.9 mV
Total tolerance	±4.3 mV	±13.9 mV
Temperature and drift response ($T_A = -25^\circ\text{C} \dots +55^\circ\text{C}$)		
Offset voltage drift T_{KVO}	±2.1 mV	±5.0 mV
Gain drift T_{KG}	±9.2 mV	±20 mV
Total voltage drift $T_{Ktot} = T_{KVO} + T_{KG}$	±11.3 mV	±25.0 mV
Total tolerance (tolerance through offset, gain, linearity, and drift)	±15.6 mV	±38.9 mV

Relative tolerance	Typical	Maximum
Tolerance at 23°C		
Total offset voltage	±0.005 %	±0.027%
Tolerance through gain	±0.025 %	±0.060%
Differential non-linearity	±0.013%	±0.027%
Total tolerance	±0.09 %	±0.14%
Temperature and drift response ($T_A = -25^\circ\text{C} \dots +55^\circ\text{C}$)		
Offset voltage drift T_{KVO}	±4 ppm/K	±10 ppm/K
Gain drift T_{KG}	±18 ppm/K	±40 ppm/K
Total voltage drift $T_{Ktot} = T_{KVO} + T_{KG}$	±23 ppm/K	±50 ppm/K
Total tolerance (tolerance through offset, gain, linearity, and drift)	±0.16 %	±0.39%

5.2 Additional tolerances influenced by electromagnetic interference

Type of electromagnetic interference	Typical deviation in % referencing the output range final value	
	Relative	Absolute
Electromagnetic fields; field strength 10 V/m according to EN 61000-4-3/IEC 61000-4-3	< ±0.2 %	< ±20 mV
Conducted interference, Class 3 (10 V test voltage) according to EN 61000-4-6/IEC 61000-4-6	< ±2.8 %	< ±280 mV

5.3 Derating

Apply a derating of 2 A/K starting from an ambient temperature of 50°C.

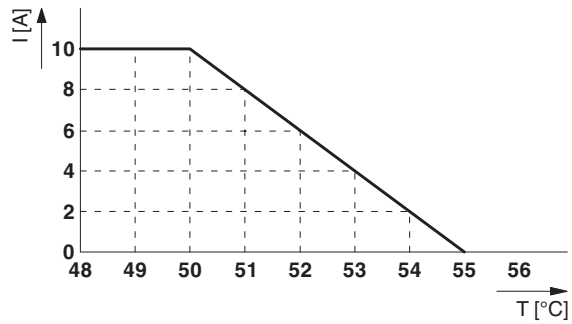

Figure 1 Derating: permissible ambient temperature depending on the current in the potential jumpers U_M and U_S (total current)

Where:

T [°C] Ambient temperature in °C
 I [A] Current through the potential jumpers U_M and U_S in A

6 Internal circuit diagram

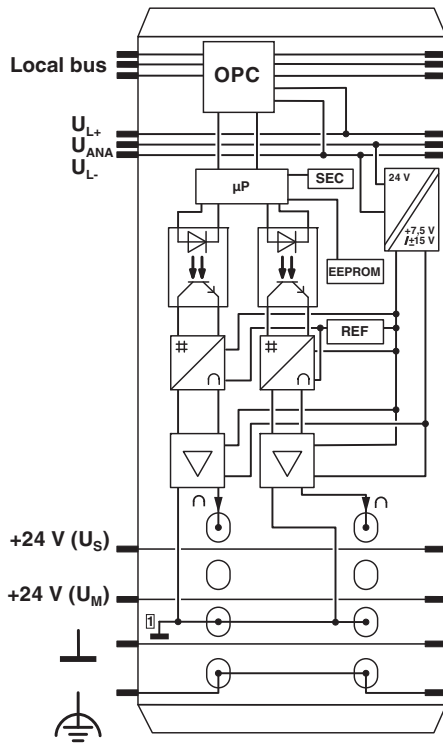
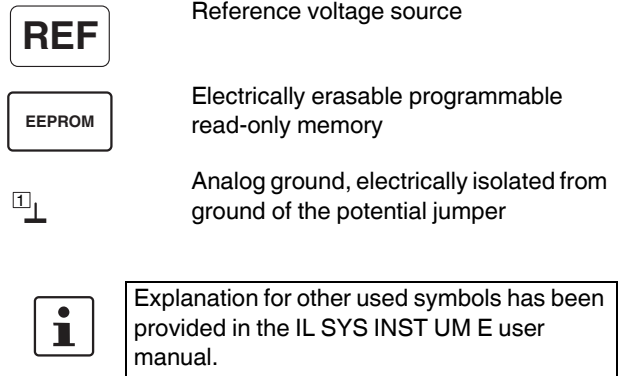
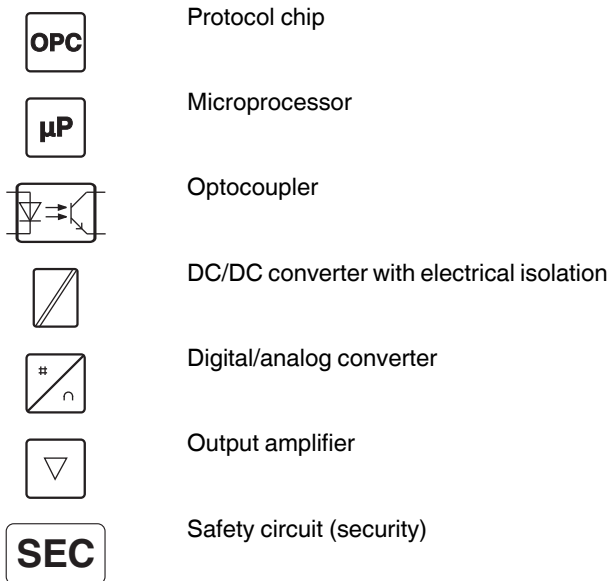

Figure 2 Internal wiring of the terminal points

Key:



7 Electrical isolation

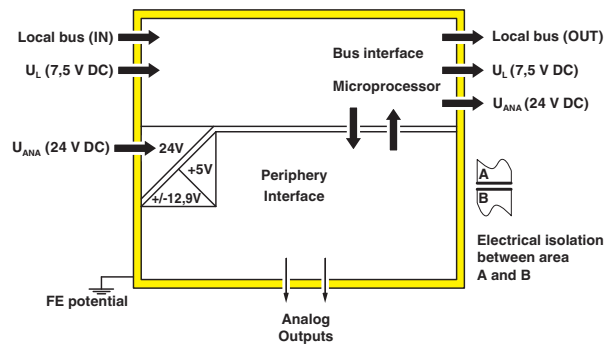

Figure 3 Electrical isolation of the individual function areas

8 Terminal point assignment

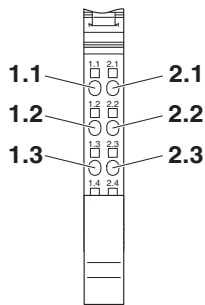

Figure 4 Terminal point assignment

Terminal point	Signal	Meaning
1.1	U1	Channel 1 voltage output
2.1	U2	Channel 2 voltage output
1.2, 2.2	-	Not used
1.3, 2.3	AGND	Analog ground
1.4, 2.4	Shield	Shield connection

9 Connection example

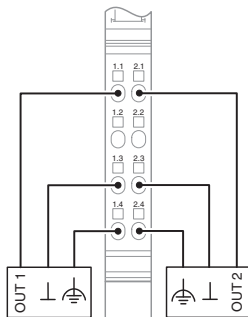

Figure 5 Connection of two voltage actuators in 2-wire technology with shield connection

10 Connection notes

Analog actuators with a cable length of <math><10\text{ m}</math> can be connected using unshielded twisted pair cables.

Connect the analog actuators with a cable length of >math>>10\text{ m}</math> using shielded twisted pair cables.

Connect one end of the shielding to PE at the Inline terminal. To do so, fold the shield on the cable back and connect it to the terminal via the shield connection clamp. The shield is connected directly to FE on the terminal side via the clamp.

Ensure that the braided shield is 15 mm longer than the strain relief when connecting a shielded actuator cable to the peripheral connector. Connect the actuator cables as described in the section "Connecting shielded cables via the shield plug".

11 Installation instructions

High current flowing through potential jumpers U_M and U_S leads to a temperature rise in the potential jumpers and inside the terminal. To keep the current flowing through the potential jumpers of the analog terminals as low as possible, always place the analog terminals after all the other terminals at the end of the main circuit (for the sequence of the Inline terminals: see also IL SYS INST UM E user manual).

12 Connecting shielded cables via the shield plug

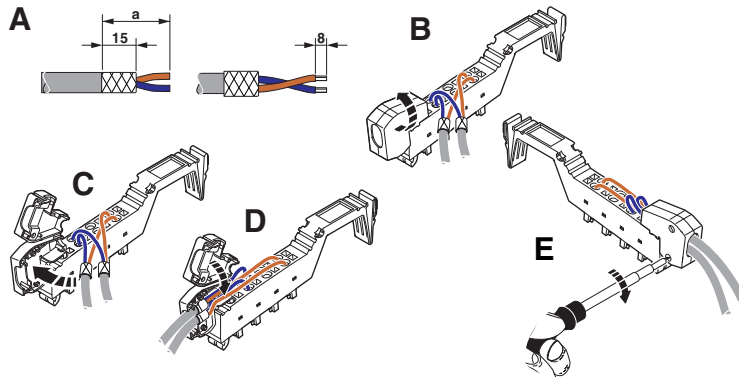

Figure 6 Connect shield via the shield plug



The diameter of the actuator cable is usually too large for the cables to be inserted into the strain relief of the shield connection with outer sheath and folded shield. Therefore, the connection procedure for these cables differs from the connection procedure described in the IL SYS INST UM Inline user manual. The differences in comparison to the user manual are marked in bold text.

When connecting the cables, proceed as shown in the figure:

Stripping cables

- Strip the outer sheath of the cables to the desired length (a). (A)
The desired length (a) depends on the connection position of the wires and whether the wires should have a large or small amount of space between the connection point and the shield connection.
- Shorten the braided shield to **20 mm**.
- Do **not** fold the braided shield back over the outer sheath. (B)
- Remove the protective foil.
- Strip 8 mm off the wires.



Inline wiring is normally carried out without ferrules. However, it is possible to use ferrules.
If using ferrules, make sure they are properly crimped.

Wire the male connectors (in accordance with the user manual)

- Push a screwdriver into the actuation shaft of the respective terminal point, so that you can insert the conductor into the spring opening. Phoenix Contact recommends the screwdriver SZF 1-0,6X3,5 (Order. No. 1204517).
- Insert the conductor. Remove the screwdriver from the opening. This results in the conductor being securely clamped.

For the terminal point assignment, see the section "Terminal point assignment"

Connecting the shield

- Open the shield connection (see user manual). (C)
- Insert the shield connection clamp into the shield connection corresponding to the cable width (see user manual).
- Place the cables in the shield connection. (D)
Push the outer sheath of the cables up to the shield connection clamp. The wires with braided shield must be underneath the shield connection clamp. The braided shield must project approximately 15 mm over the shield connection clamp.
- Close the shield connection. (E)
- Fasten the screws of the shield connection tightly with a screwdriver. (F)

13 Local diagnostic and status indicators



Figure 7 Local diagnostic and status indicators

Designation	Color	Meaning
D	Green	Diagnostics (bus and logic voltage)
O-S	Orange	Original delivery is parameterized by default



For detailed information on diagnostics, please refer to the IL SYS INST UM E user manual.

Function identification

Yellow

14 Process data

The terminal uses two words of IN process data and two words of OUT process data.

Order of the process data words:

Input word	Word 0	Word 1
Output word	Word 0	Word 1

14.1 OUT process data

(Word.bit) view	Word	Word 0					Format
	Bit	15	14 ... 3	2	1	0	
Assignment	V		AW1	X	X	X	IB IL
	V		AW1	X	X	X	IB ST

(Word.bit) view	Word	Word 1					Format
	Bit	15	14 ... 3	2	1	0	
Assignment	V		AW2	X	X	X	IB IL
	V		AW2	X	X	X	IB ST

V Sign bit
 AW1 Output value channel 1
 AW2 Output value channel 2
 X Non-relevant bits. Set these bits to "0".
 Format Format of output data

14.2 IN process data

Bits 15 to 3 of the process data output values are mirrored in the IN process data. Bit 15 is the sign bit in this case. Bits 2 to 0 are available as status bits. The bits contain information on the parameterized behavior of the terminal.

(Word.bit) view	Word	Word 0				
	Bit	15	14 ... 3	2	1	0
Assignment	V		AW1*	F	B	H

(Word.bit) view	Word	Word 1				
	Bit	15	14 ... 3	2	1	0
Assignment	V		AW2*	F	B	H

V Sign bit
 OV1* Mirrored channel 1 output value
 OV2* Mirrored channel 2 output value
 F Format of output data
 B Voltage range
 H HOLD/RESET

Bits 2 to 0 have the following meaning:

Bit	Designation	Meaning	Bit x = 0	Bit x = 1
2	F	Format of output data	IB IL	IB ST
1	B	Voltage range	-10 V ... +10 V	0 V ... 10 V
0	H	HOLD/RESET	HOLD	RESET

14.3 Assignment of the terminal points to the output process data

(Word.bit) view	Word	Word 0															
	Bit	15	14	13	12	11	10	9	8	7	6	5	4	3	2	1	0
(Byte.Bit) view	Byte	Byte 0								Byte 1							
	Bit	7	6	5	4	3	2	1	0	7	6	5	4	3	2	1	0
Assignment	IB IL format	V	Output value channel 1												0	0	0
	IB ST format	V	Output value channel 1												0	0	0
Terminal points	Signal	Terminal point 1.1: voltage output 1															
	AGND	Terminal point 1.3: analog ground															
	Shield	Terminal point 1.4															

(Word.bit) view	Word	Word 1															
	Bit	15	14	13	12	11	10	9	8	7	6	5	4	3	2	1	0
(Byte.Bit) view	Byte	Byte 2								Byte 3							
	Bit	7	6	5	4	3	2	1	0	7	6	5	4	3	2	1	0
Assignment	IB IL format	V	Output value channel 2												0	0	0
	IB ST format	V	Output value channel 2												0	0	0
Terminal points	Signal	Terminal point 2.1: voltage output 2															
	AGND	Terminal point 2.3: analog ground															
	Shield	Terminal point 2.4															

15 Formats for representing the output values



The IB IL AO 2/U/BP-PAC terminal format is compatible with the IB IL AI 2/SF-PAC input terminal. This makes it possible to use these terminals in multiplexer systems (e.g., IB IL MUX MA-PAC).

The format IB IL is preset on the terminal (default). To ensure that the terminal can be operated in the ST data format, the output value representation can be switched to the IB ST format.

15.1 IB IL format

The output value is represented in bits 14 to 0. An additional bit (bit 15) is available as a sign bit.

Output value representation in IB IL format (15 bits + sign)

15	14	13	12	11	10	9	8	7	6	5	4	3	2	1	0
V	Analog value												X	X	X

- V Sign bit
- X Non-relevant bits. Set these bits to "0".

Significant values

In the -10 V to +10 V output range, the values are output with a resolution of 13 bits.

In the 0 V to 10 V output range, the values are output with a resolution of 12 bits.



Bits 2 to 0 are not always considered "non-relevant bits". For the operation of the field multiplexer, it is necessary that error messages and over-range or under-range information be appropriately evaluated. In the case of over-range (8001_{hex}), the output is 10.837 V, and for under-range (8080_{hex}) the output is 0 V. In the case of an error code (1000 0000 0xxx xxx0_{bin}), the last valid value from the digital-to-analog converter continues to be output.

Output data word (two's complement)		-10 V ... +10 V	0 V ... 10 V	Notes
hex	dec	V	V	
≤ 7FFF	32767	+10.837		
> 7F00	32512	+10.837	+10.837	
7F00	32512	+10.837	+10.837	
7530	30000	+10.0	+10.0	
0008	8	+2.667 mV	+2.667 mV	Smallest quantization step of the digital-to-analog converter
0001	1	+333.33 μV	+333.33 μV	Process data resolution
0000	0	0	0	
< 0000			0	
FFF8	-8	-2.667 mV		
8AD0	-30000	-10.0		
8100	-32512	-10.837		
< 8100	Special handling			
8001	-32767	+10.837	+10.837	Overrange
8080	-32640	-10.837	0	Underrange
80xx	Other	Hold last value	Hold last value	

15.2 IB ST format

The output value is represented in bits 14 to 3. Bits 2 to 0 are non-relevant.

An additional bit (bit 15) is available as a sign bit.

IB ST format corresponds to the data format used on INTERBUS ST modules.

Output value representation in IB ST format (12 bits + sign)

15	14	13	12	11	10	9	8	7	6	5	4	3	2	1	0
V	Analog value												X	X	X

- V Sign bit
- X Non-relevant bits. Set these bits to "0".

Significant values



Bits 2 to 0 are not always considered "non-relevant bits". The values 7FF9_{hex} or 8001_{hex} are recognized as over-range or under-range indications and interpreted as 7FF8_{hex} or 8008_{hex} and processed as normal process data thereafter. This ensures MUX compatibility. The only exceptions are the error codes (for ST, open circuit only). In the case of this error code (xxxx xxxx xxxx xx1_{x_{bin}}), the last value is retained.

Output data word (two's complement)		-10 V ... +10 V	0 V ... 10 V
hex	dec	V	V
> 7FF8	Overrange	+9.9975	+9.9975
7FF8	32760	+9.9975	+9.9975
4000	16384	+5.0	+5.0
0008	8	+0.002441	+0.002441
0000	0	0	0
< 0000			0
FFF8	-8	-0.002441	
8008	-32760	-9.9975	
< 8008		-9.9975	

16 Output behavior

16.1 Output behavior during error-free operation (normal operation)

On power up during normal operation, the output range and the data format are read from the terminal EEPROM (non-volatile).

Volatile parameterization is also possible for these settings as well as for the behavior of the terminal in the event of an error. You can carry out this parameterization during runtime by using a process data sequence.

16.2 Behavior of the outputs in the event of an error

In the event of an error, the outputs behave as set in the EEPROM (non-volatile) or based on how you have subsequently parameterized it (volatile). That means the outputs retain the last value (HOLD, default setting) or they return to zero (RESET, can be parameterized).

16.3 Output voltage behavior



When configuring your system, take into account output behavior in the event of an error

Switching operation/state of the supply voltage	Marginal condition	OUT process data word [hex]	Behavior/status of the analog output
U_{ANA} from 0 V to 24 V	$U_L = 0 V$	xxxx	0 V
U_{ANA} from 24 V to 0 V	$U_L = 7.5 V$	xxxx	0 V
Bus in stop state	$U_{ANA} = 0 V$	xxxx	0 V
Bus in stop state	$U_{ANA} = 24 V$	xxxx	Hold last value
Bus reset (e.g., remote bus cable break)		xxxx	Retain the last value (default) or 0 V (can be parameterized)

- U_{ANA} Analog supply voltage of the terminal
- U_L Supply voltage for module electronics (communications power)
- xxxx Any value in the range from 0000_{hex} ... $FFFF_{hex}$

17 Input behavior

In order to analyze the input behavior, a distinction is made between normal operation and parameterization mode. The input behavior in parameterization mode is described in the section "Parameterization".

During **error-free normal operation**, the output data is mirrored in the input words as "acknowledgment" in bits 15 to 3 as soon as it has been transmitted to the digital-to-analog converter.

Bits 2 to 0 are available as status bits. You can use them to read back the terminal behavior setting.

Since the terminal only interprets bits 15 to 3 as data bits in both the IB IL and IB ST data format, only these 13 bits are mirrored in the input data word (see the remarks on error codes, over-range, and under-range). See Section "IN process data".

If an error is detected by the terminal, it is indicated by means of an error code in the first IN process data word (Word 0).

Error codes

Input data word (two's complement, hex)	Cause	Corrective	Note
8010	This code can only appear in parameterization mode. It can occur for two reasons:		
	1. Parameterization is being carried out	Continue the parameterization.	In the second step of the parameterization, this code appears after the Code 8055 _{hex} is set in the first input word. It does not indicate an error in this case.
	2. Parameterization invalid	Check the parameterization.	
8020	Digital-to-analog converter voltage has fallen below the permissible value.	Check the supply voltage.	The terminal triggers a peripheral fault.
		Check to ensure that the potential jumpers are connecting securely.	
		Replace the terminal.	
8040	Device faulty	Replace the terminal.	



The error codes overwrite the status bits (bits 2 ... 0) with "0". This makes it possible to clearly differentiate them from valid process data in the IB ST data format as well.

18 Parameterization

Parameter	Delivery state	Can be parameterized
Data format	IB IL	IB ST
Behavior of the outputs in the event of an error	Retain last value (Hold)	Set outputs to 0 (Reset)
Output range	-10 V ... +10 V	0 V ... 10 V

In order to parameterize the terminal, you must change to parameterization mode. This is done by transmitting the codes 8033_{hex} and 8055_{hex} consecutively in the first process data output word.



- To avoid accidentally switching to parameterization mode, set bits 2 to 0 to "0" during normal operation when transmitting process data.
- The parameterization applies for both channels.

Parameterize terminal

Step	Measure	Note
1	OUT0 = 8033 _{hex} In bits 15 ... 3 of IN0, this code is acknowledged as a normal process data item.	For each subsequent code in OUT0 that is not equal to 8055 _{hex} , no exit from normal operation occurs and the code is interpreted as process data.
	OUT0 = 8055 _{hex} Acknowledgment: IN0 = 8010 _{hex} In this case, this code does not indicate an error, but rather indicates that a configuration word is expected next (in Step 3).	
3	OUT0 = 1000 0000 1000 p ₃ p ₂ p ₁ 1 _{bin} Where p _x are the terminal parameters. p ₃ : data format p ₂ : output range p ₁ : behavior in the event of an error	For each subsequent code in OUT0 that is not equal to 80xx _{hex} , the system exits from parameterization mode.
	Acceptance of the value is confirmed in bits 15 ... 0 of IN0 through mirroring of the code. If an invalid configuration is indicated, then the code 8010 _{hex} appears in IN0. When this occurs, it is signaling the error "Parameterization invalid".	
	This step can be repeated as often as you wish.	
4	In this step, you determine whether the parameterization is saved in the EEPROM dynamically (volatile) or statically (non-volatile).	Transmitting a code not equal to 80xx _{hex} in OUT0 will cause the system to exit parameterization mode without applying the parameterization.
	Volatile parameterization: OUT0 = 8077 _{hex} This setting disappears after a power-up. The setting from the EEPROM is used in further operation.	
	Non-volatile parameterization: OUT0 = 8099 _{hex} The parameterization is stored in the EEPROM. This parameterization from the EEPROM is used after a power up.	
	After writing 8077 _{hex} or 8099 _{hex} , the parameterization is applied and the system exits parameterization mode. This is indicated in IN0 by mirroring the code 8077 _{hex} or 8099 _{hex} . These values are solely for acknowledgment purposes here. Completely normal processing starts with the next process data item.	



If the parameterization is interrupted, you can only switch back to parameterization mode by restarting from step 1. The orange "O-S" LED on the terminal indicates whether the original parameterization is present or whether the active parameterization differs from the default configuration of the terminal upon delivery. The LED is on if the default state has been parameterized.

Parameter		0	1
p ₃	Data format	IB IL	IB ST
p ₂	Output range	-10 V ... +10 V	0 V ... 10 V
p ₁	Behavior of the outputs in the event of an error	Retain last value (Hold)	Set outputs to 0 (Reset)