

IB IL 24 DI 16-ME

Inline Terminal With 16 Digital Inputs

AUTOMATIONWORX

Data Sheet
7444_en_00

© PHOENIX CONTACT - 11/2006

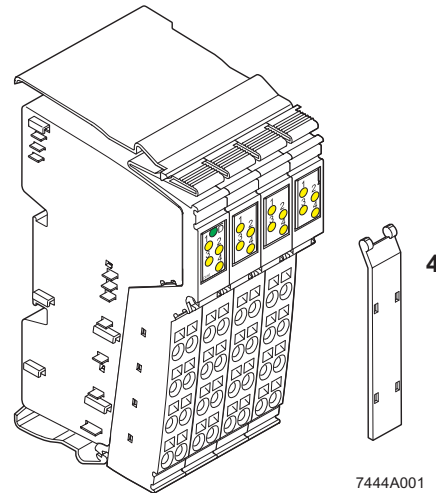

Description

The terminal is designed for use within an Inline station. It is used to acquire digital input signals.

Features

- Connections for 16 digital sensors
- Connection of sensors in 2 and 3-wire technology
- Maximum permissible load current per sensor: 250 mA
- Maximum permissible load current from the terminal: 4.0 A
- Diagnostic and status indicators



This data sheet is only valid in association with the IB IL SYS PRO UM E user manual or the Inline system manual for your bus system.



Make sure you always use the latest documentation.
It can be downloaded at www.download.phoenixcontact.com.
A conversion table is available on the Internet at
www.download.phoenixcontact.com/general/7000_en_00.pdf.

Ordering Data

Products

Description	Type	Order No.	Pcs./Pck.
Terminal with 16 digital inputs including connectors (with consecutive numbering) and labeling fields	IB IL 24 DI 16-ME	2897156	1

Documentation

Description	Type	Order No.	Pcs./Pck.
"Configuring and Installing the INTERBUS Inline Product Range" user manual	IB IL SYS PRO UM E	2743048	1

Accessories

Description	Type	Order No.	Pcs./Pck.
Terminal for potential distribution 24 V; including connector and labeling field	IB IL PD 24V-PAC	2862987	1
Terminal for potential distribution GND; including connector and labeling field	IB IL PD GND-PAC	2862990	1

Technical Data

General Data

Order designation (Order No.)	IB IL 24 DI 16-ME (2897156)
Housing dimensions (width x height x depth)	48.8 mm x 120 mm x 71.5 mm
Weight	122 g (without connectors)
Operating mode	Process data mode with 1 word
Transmission speed	500 kbaud
Connection method for sensors	2 and 3-wire technology
Permissible temperature (operation)	-25°C to +55°C
Permissible temperature (storage/transport)	-25°C to +85°C
Permissible humidity (operation/storage/transport)	10% to 95%, according to DIN EN 61131-2
Permissible air pressure (operation/storage/transport)	70 kPa to 106 kPa (up to 3,000 m above sea level)
Degree of protection	IP20 according to IEC 60529
Protection class	Class 3 in acc. with VDE 0106, IEC 60536

Interface

Local bus	Via data routing
-----------	------------------

Power Consumption

Communications power	7.5 V
Current consumption from the local bus	60 mA, maximum
Power consumption from the local bus	0.45 W, maximum
Segment supply voltage U_S	24 V DC (nominal value)
Nominal current consumption at U_S	4 A, maximum

Supply of the Module Electronics and I/O Through Bus Terminal/Power Terminal

Connection method	Through potential routing
-------------------	---------------------------

Digital Inputs	
Number	16
Input design	According to EN 61131-2 Type 1
Definition of switching thresholds	
Maximum low-level voltage	$U_{Lmax} < 5 \text{ V}$
Minimum high-level voltage	$U_{Hmin} > 15 \text{ V}$
Common potentials	Segment supply, ground
Nominal input voltage U_{IN}	24 V DC
Permissible range	$-3 \text{ V} < U_{IN} < +30 \text{ V DC}$
Nominal input current for U_{IN}	3 mA, minimum
Delay time	None
Permissible cable length to the sensor	30 m (to ensure conformance with EMC directive 89/336/EEC)
Use of AC sensors	AC sensors in the voltage range $< U_{IN}$ are limited in application (corresponding to the input design)

Characteristic Curve: Current Depending on the Input Voltage and the Ambient Temperature T_A			
Supply Voltage	Input Current	Input Current for $t \geq 20 \text{ s}$	
		For $T_A = 25^\circ\text{C}$	For $T_A = 55^\circ\text{C}$
18 V	3.0 mA	2.9 mA	2.5 mA
24 V	3.9 mA	3.8 mA	3.5 mA
30 V	4.5 mA	4.2 mA	3.0 mA

The current is reduced depending on the ambient temperature T_A and the number of inputs that are switched on (internal terminal temperature).

Power Dissipation

Formula to Calculate the Power Dissipation of the Electronics

$$P_{TOT} = 0.525 \text{ W} + \sum_{n=1}^{16} [U_{INn} \times 0.003 \text{ A}]$$

Where:

P_{TOT} = Total power dissipation in the terminal

n = Index of the number of set inputs $n = 1$ to 16

U_{INn} = Input voltage of input n

Power dissipation of the housing P_{HOU}	2.8 W, maximum (within the permissible operating temperature)
--------------------------------------------	---------------------------------------------------------------

Limitation of Simultaneity, Derating

Derating	No limitation of simultaneity, no derating
----------	--------------------------------------------

Safety Equipment

Overload in segment circuit	No
Surge voltage	Protective elements of the power terminal
Polarity reversal	Protective elements of the power terminal

Electrical Isolation/Isolation of the Voltage Areas



To provide electrical isolation between the logic level and the I/O area it is necessary to supply the station bus terminal and the digital input terminal described here via the bus terminal or a power terminal from separate power supply units. Interconnection of the power supply units in the 24 V area is not permitted. (See also user manual.)

Common Potentials

The 24 V main voltage, 24 V segment voltage, and GND have the same potential. FE is a separate potential area.

Separate Potentials in the System Consisting of Bus Terminal Module/Power Terminal and I/O Terminal

- Test Distance

5 V supply outgoing remote bus/7.5 V supply (bus logic)

5 V supply outgoing remote bus/7.5 V supply (bus logic)

7.5 V supply (bus logic) / 24 V supply (I/O)

24 V supply (I/O) / functional earth ground

- Test Voltage

500 V AC, 50 Hz, 1 min.

500 V AC, 50 Hz, 1 min.

500 V AC, 50 Hz, 1 min.

500 V AC, 50 Hz, 1 min.

Error Messages to the Higher-Level Control or Computer System

None

Approvals

For current approvals please refer to www.download.phoenixcontact.com.

Local Diagnostic and Status Indicators

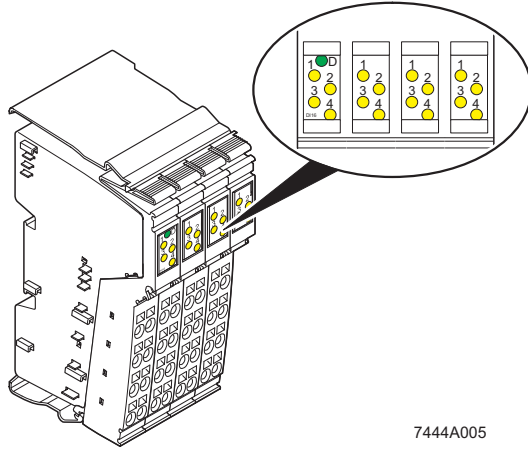

7444A005

Figure 1 Local diagnostic and status indicators

Local Diagnostic and Status Indicators

Designation	Color	Meaning
D	Green	Diagnostics
For Each Connector		
1, 2, 3, 4	Yellow	Status indicators of the inputs

Terminal Assignment per Connector

Terminal Point	Assignment
x.1	Signal input (IN)
x.2	Segment voltage U_S for 2 and 3-wire termination
x.3	Ground contact (GND) for 3-wire termination
x.4	Signal input (IN)

Function Identification

Dark blue

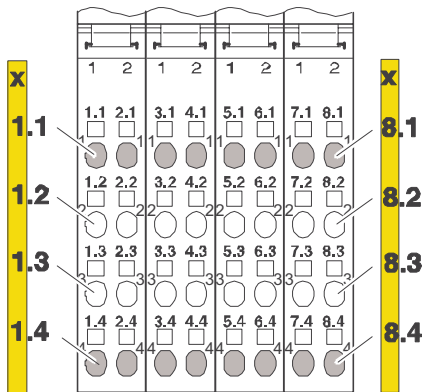

7444A002

Figure 2 Terminal point numbering

Internal Circuit Diagram

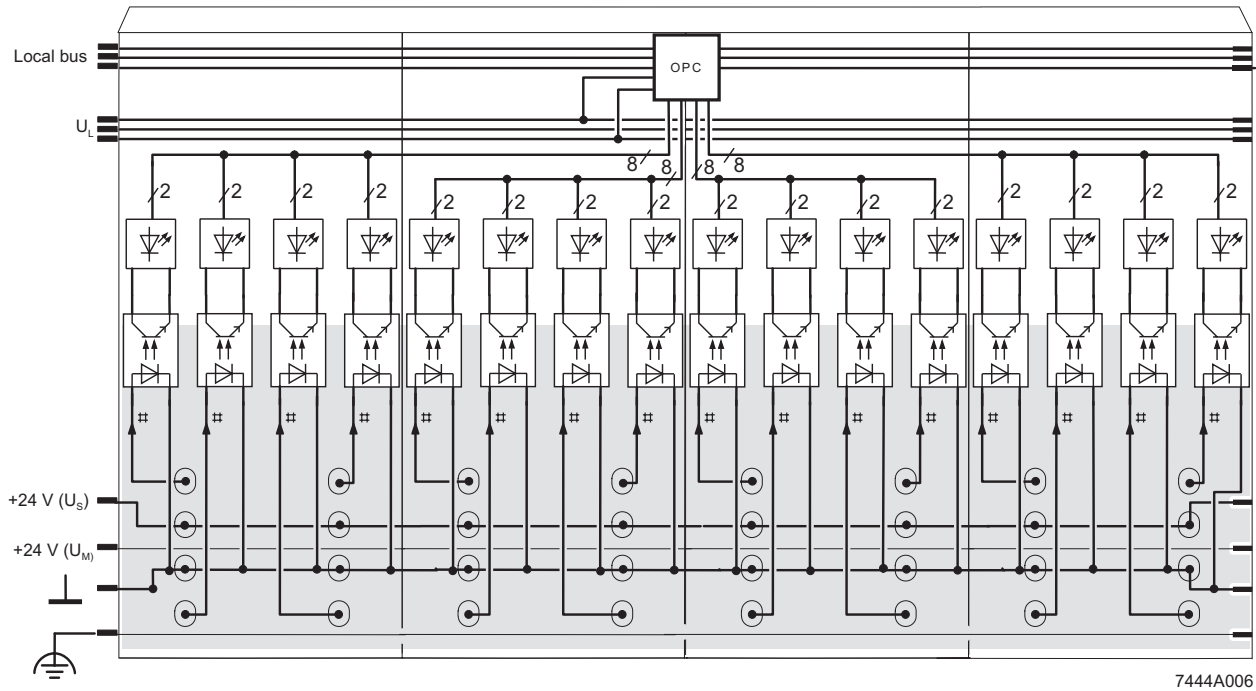







Figure 3 Internal wiring of the terminal points

Key:

-  Protocol chip (bus logic including voltage conditioning)
-  LED
-  Optocoupler
-  Digital input
-  Electrically isolated area



Other symbols used are explained in the IB IL SYS PRO UM E user manual or the system manual for your bus system.

Connection Notes and Connection Example



Please note that the terminal must be provided with supply voltage U_S , as it is used internally as the auxiliary supply.



When connecting the sensors, observe the assignment of the terminal points to the process data, see page 9.

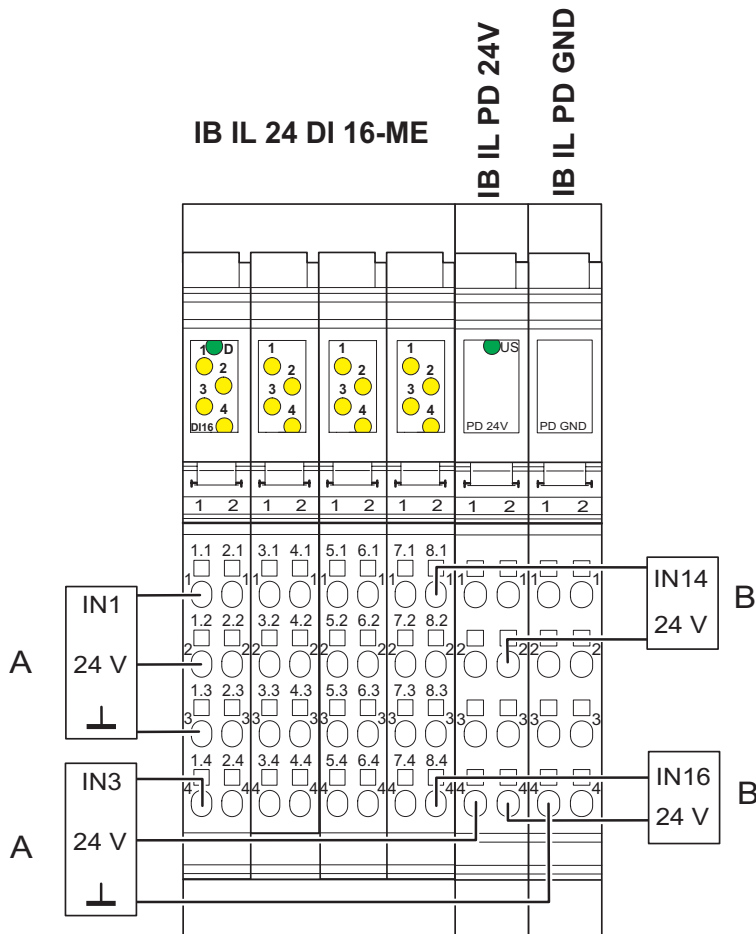

7444A003

Figure 4 Typical sensor connections

- A 3-wire termination
- B 2-wire termination

The sensors can also be connected via external busbars. Ensure that the sensors and U_S are supplied from the same voltage supply.



Ensure that the Inline system ground is reference for at least the ground when using external busbars.

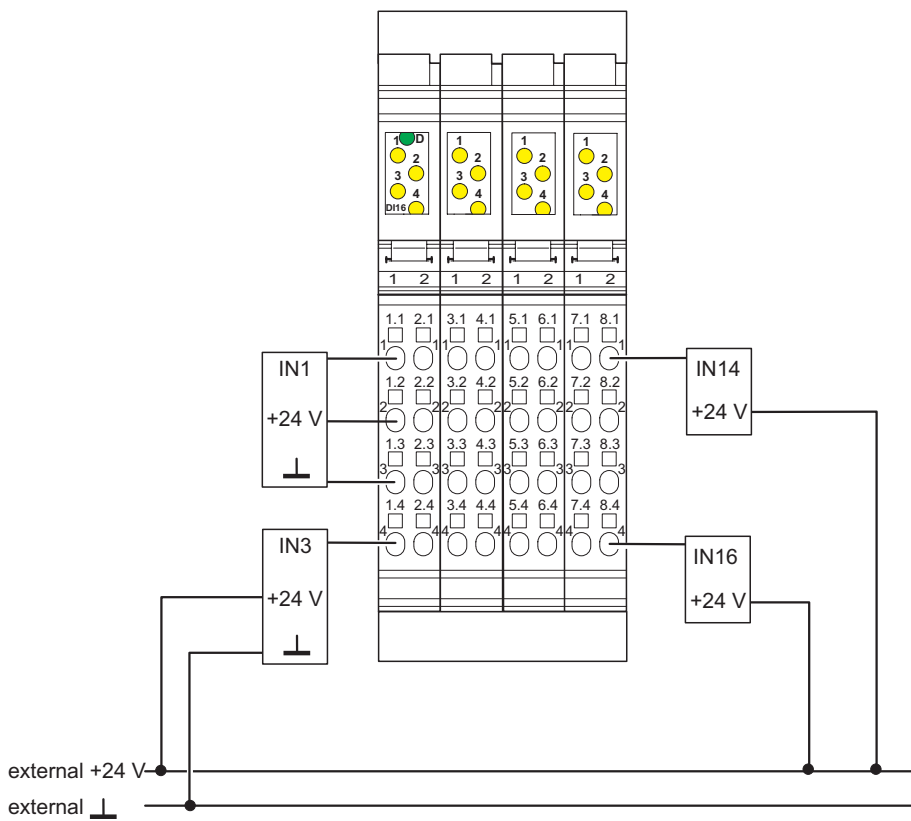

7444A004

Figure 5 Typical connection of sensors when using external busbars

Programming Data/Configuration Data

INTERBUS

ID code	BE _{hex} (190 _{dec})
Length code	01 _{hex}
Process data channel	16 bits
Input address area	2 bytes
Output address area	0 bits
Parameter channel (PCP)	0 bits
Register length (bus)	2 bytes

Other Bus Systems



For the programming data of other bus systems, please refer to the corresponding electronic device data sheet (GSD, EDS).

Process Data



For the assignment of the illustrated (byte.bit) -view to your **INTERBUS** control or computer system, please refer to the DB GB IBS SYS ADDRESS data sheet, Order No. 9000990.

For the assignment of the illustrated (byte.bit)-view to control systems of **other bus systems**, please refer to the AH IB IL 24 DI/DO 16 ADDRESS document, Order No. 9014124.

Assignment of the Terminal Points to the IN Process Data



The following table applies to the IB IL 24 DI 16-ME terminal with the original connector set.

(Word.bit) view	Word	Word 0															
	Bit	15	14	13	12	11	10	9	8	7	6	5	4	3	2	1	0
(Byte.bit) view	Byte	Byte 0								Byte 1							
	Bit	7	6	5	4	3	2	1	0	7	6	5	4	3	2	1	0
Module	Slot	4				3				2				1			
	Terminal point (signal)	8.4	7.4	8.1	7.1	6.4	5.4	6.1	5.1	4.4	3.4	4.1	3.1	2.4	1.4	2.1	1.1
	Terminal point (+24 V)			8.2	7.2			6.2	5.2			4.2	3.2			2.2	1.2
	Terminal point (GND)			8.3	7.3			6.3	5.3			4.3	3.3			2.3	1.3
Status indicator	Slot	4				3				2				1			
	LED	4	3	2	1	4	3	2	1	4	3	2	1	4	3	2	1