



TAC
 1354 Clifford Avenue
 P. O. Box 2940
 Loves Park, IL 61132-2940
 www.tac.com

Parts & Accessories Data Sheet

The TAC Pneumodular Control System is designed to ease the assembly and installation of a pneumatic control system in several ways. The modularity of design and assembly speeds the pre-building of panels and simplifies field hookup through the use of easily identified connections. The modular format allows the use of simplified engineering drawing symbols developed specifically for TAC Pneumodular controls so that panels may be built "as drawn" directly from the submittal drawings. In addition, final system start-up and calibration checks are made easier because the panels match the drawings they were built from, thereby saving field labor time.

This data sheet details the parts and accessories that are utilized in the assembly of a TAC Pneumodular control panel. It starts with the accessories and concludes with the installation and piping of the devices to make up a TAC Pneumodular control system.

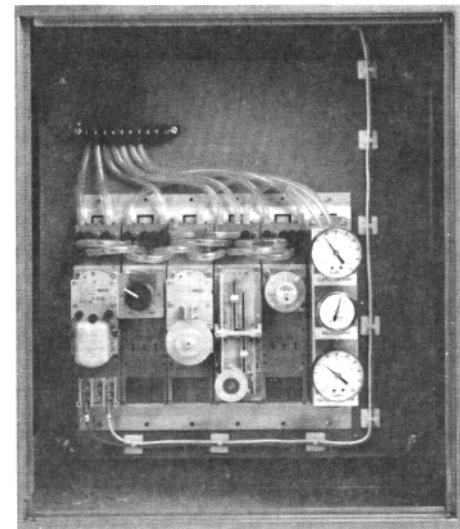

PANELS

A variety of enclosures or panels are available for use with TAC Pneumodular and other control devices, Figure 1. These enclosures come in two styles, a universal type with removable backplate, and a series designed expressly for the TAC Pneumodular control system, which have a one piece bezel and backplate assembly that is removable. This allows the panels to be stacked or flush mounted.

The TAC Pneumodular panels are available with either window or blank door. The window door models allow the monitoring of system operation (gauge read-outs and set points), while maintaining a locked cabinet to avoid unauthorized tampering. Two sizes are available; one which will accept up to a 6 place backplate and one which will accept up to a 12 place backplate. If it is necessary to install more than 12 devices in a particular panel, the universal models will accept one or two 10 place backplates depending on the panel size.

All models include a lock and keys. The TAC Pneumodular panels are a solid brown and the universal models are brown with a tan door.

Table-1 Panels Ordering Information.

TAC Wholesale Number	Replaces Model	Description
Standard Panels		
21-614	N100-9900	Ring Panel, Left or Right Hinge 24 x 24 x 8
21-615	N100-9901	Ring Panel, Left or Right Hinge 24 x 32 x 8
TAC Pneumodular Panels		
22-180	PCP-12BD	Blank Door, Left or Right Hinge 30 x 21 x 7
22-181*	PCP-12WL	Window Door, Left Hinge 12 Place, 30 x 21 x 7
22-182*	PCP-12WR	Window Door Right Hinge 12 Place, 30 x 21 x 7
22-183	PCP-6BD	Blank Door, Left or Right Hinge 6 Place, 18 x 21 x 7
22-184*	PCP-6WL	Window Door, Left Hinge 6 Place, 18 x 21 x 7
22-185*	PCP-6WR	Window Door, Right Hinge 6 Place, 18 x 21 x 7
*Windows Must Be Ordered Separately		
22-195	PLEX-12	Plexiglass Window, 12 Place Panel
22-196	PLEX-6	Plexiglass Window, 6 Place Panel
21-617	N100-9915	Lock and Key Assembly

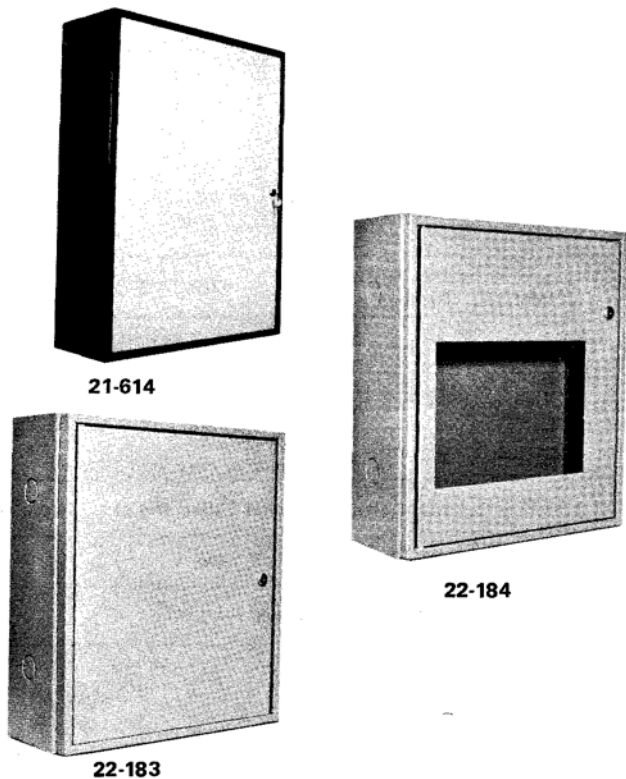

Figure-1 Panels.

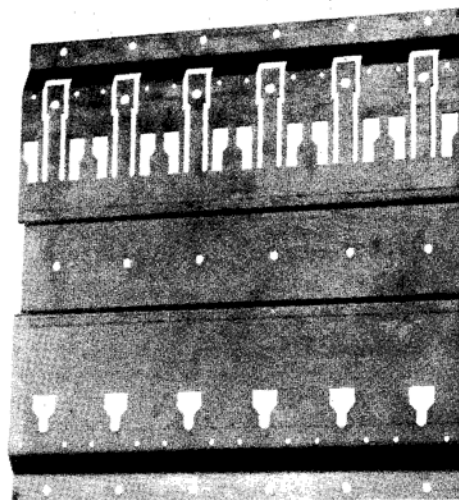

Figure-2 Backplates.

BACKPLATES

The backbone of a TAC Pneumodular control panel is the backplate, Figure 2. Backplates for the TAC Pneumodular system come in five convenient sizes to accept 1, 4, 6, 10 or 12 devices per backplate. The backplates are predrilled for mounting to panel backs or other mounting surfaces as necessary with standard sheet metal screws, and may be used singularly or in combination as needed for a particular application.

Table-2 Backplates Ordering Information.

Order Number	Factory Number	Dimensions		Descriptions
		Height	Width	
22-101	MCS-BP1	10"	2"	1 Place Backplate
22-104	MCS-BP4	10"	8"	4 Place Backplate
22-106	MCS-BP6	10"	12"	6 Place Backplate
22-110	MCS-BP10	10"	20"	10 Place Backplate
22-112	MCS-BP12	10"	24"	12 Place Backplate

SOCKET

The socket assembly (22-120) snaps directly into the backplate and locks into place providing the mounting base for the TAC Pneumodular devices, Figure 3. Each socket is furnished with a plug strip (22-130) preinstalled to seal the five end ports across the top of the socket. Any number of plugs may be removed as needed in order to access these ports which are common to their respective rows of three tubing connections on the socket face. In addition, there is a space provided on the socket for placing a device identification label (22-132). Sockets may be removed by depressing the locking tab on the backplate and pushing the socket upwards.

Measurement of selected input or output pressures may be done through the use of a check valve assembly (22-137) which can be installed in the respective end port of the socket. The 22-137 check valve assembly may be installed temporarily or permanently. An air gauge or receiver gauge adaptor (22-138) is used to measure the selected pressure. This gauge may be left installed in the check valve assembly if it is desired to continuously monitor the selected pressure.

Table-3 Socket Ordering Information.

Order Number	Replaces Model	Description
22-120	MCS-S	Socket Assembly (includes one 22-130)
22-130	MCS-PS	Plug Strip
2890-530	MCS-PS	Plug Strip Quantity Package (25 ea.)
22-132	MCS-Label	Socket Labels (5 Cards, 24 per card)
22-137	MCS-CV	Check Valve
22-138	MCS-GA	Gauge Adaptor

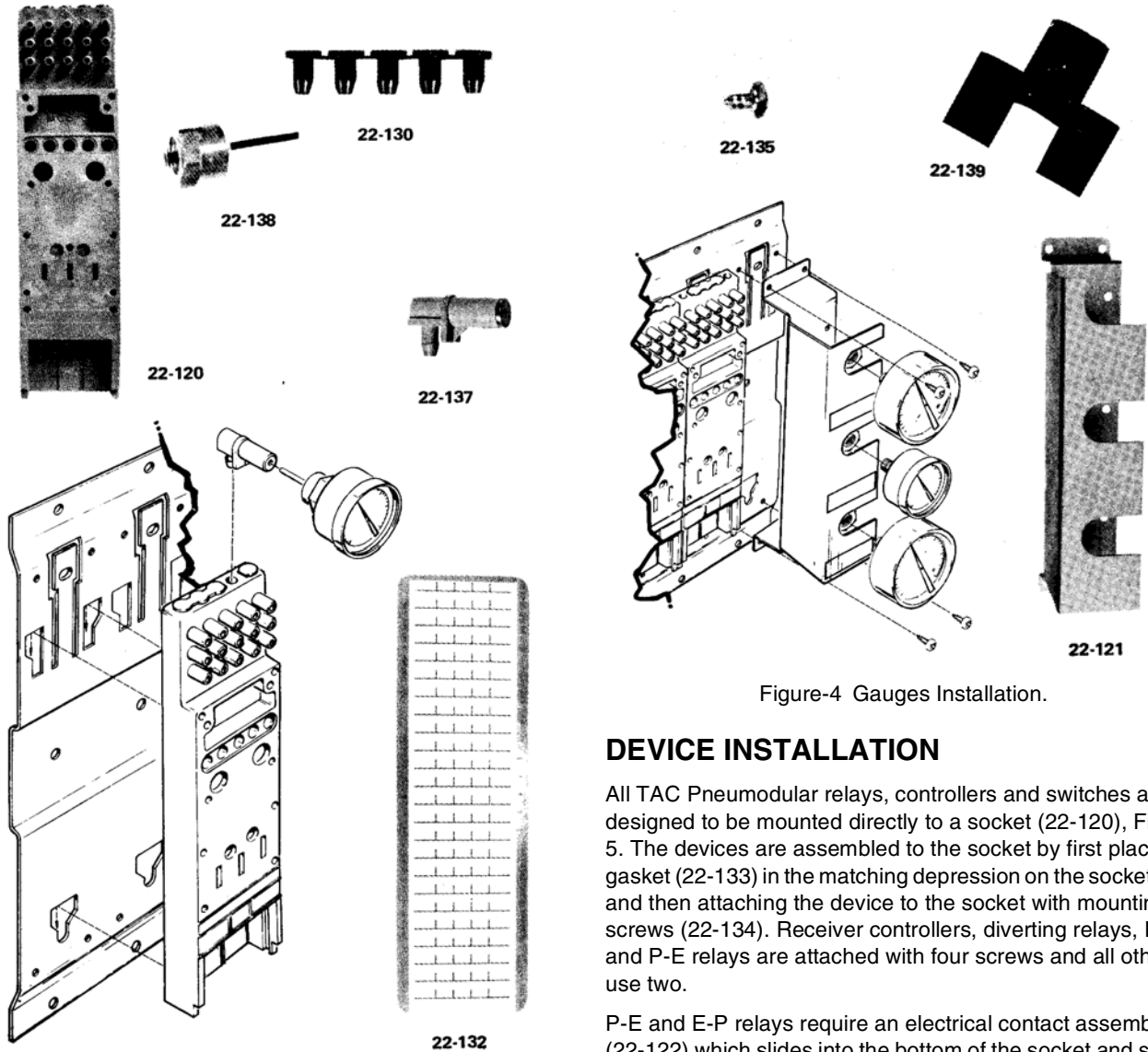

Figure-3 Sockets Installation.

GAUGE INSTALLATION

To facilitate the mounting of pressure or receiver gauges on the panel, a gauge module (22-121) is used, Figure 4. This module will accept up to three 1/8" pipe, back connected gauges, each mounted on a gauge module fitting (22-139). These fittings are installed on the gauge module as needed. Gauges may be either 1-1/2" or 2" diameter sizes. The gauge module is attached to the backplate with four 22-135 mounting screws. These same screws are used to attach the gauge fittings to the gauge module.

Table-4 Gauge Ordering Information.

Order Number	Replaces Model	Description
22-121	MCS-GM	Gauge Module
22-139	MCS-GMF	Gauge Mounting Fitting
22-135	MCS-MS	Mounting Screw
2890-535	MCS-MS	Mounting Screw Quantity Package (100)

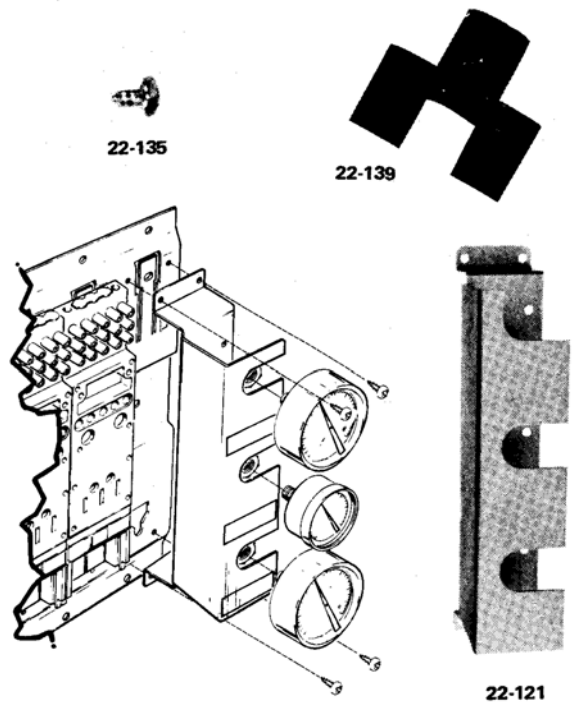

Figure-4 Gauges Installation.

DEVICE INSTALLATION

All TAC Pneumodular relays, controllers and switches are designed to be mounted directly to a socket (22-120), Figure 5. The devices are assembled to the socket by first placing a gasket (22-133) in the matching depression on the socket face and then attaching the device to the socket with mounting screws (22-134). Receiver controllers, diverting relays, E-P and P-E relays are attached with four screws and all others use two.

P-E and E-P relays require an electrical contact assembly (22-122) which slides into the bottom of the socket and snaps into place. An optional electrical barrier (22-136) may be added if required.

Table-5 Device Ordering Information.

Order Number	Replaces Model	Description
22-120	MCS-S	Socket Assembly (includes one 22-130)
22-133	MCS-6	Gasket
2890-533	MCS-G	Gaskets Quantity Package (25)
22-134	MCS-Screw	Device Mounting Screw
2890-534	MCS-Screw	Device Mounting Screws Quantity Package (100)
22-122	MCS-EC	Electrical Contact Assembly
2890-522	MCS-EC	Electrical Contact Assembly Quantity Package (10)
22-136	MCS-EB	Electrical Barrier
2890-536	MCS-EB	Electrical Barrier Quantity Package (10)

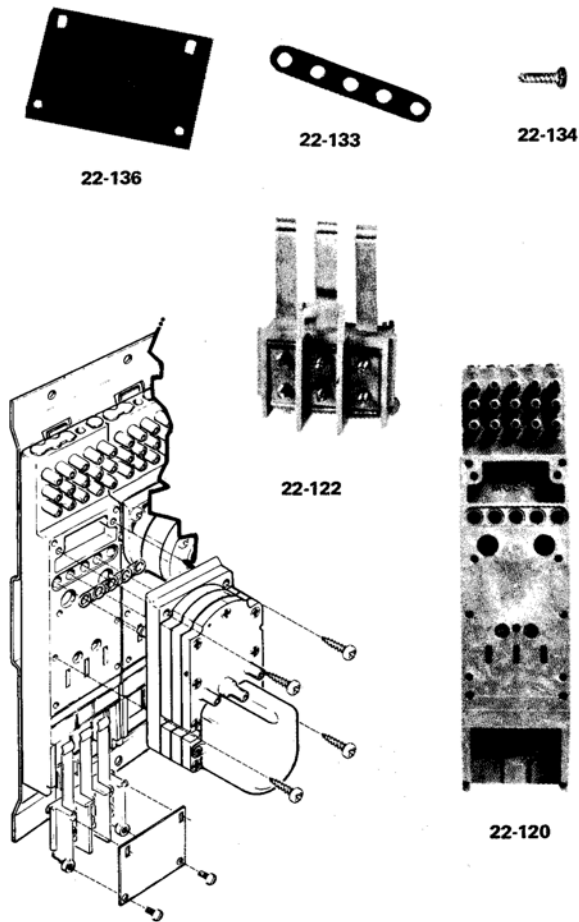

Figure-5 Device Installation.

PIPING INSTRUCTIONS

After the individual controls are installed on sockets and in position on the backplate, it is time to pipe them together as shown in Figure 6. This is done with 2803 Series TAC Pneumodular tubing. This tubing is a 5/32" I.D., thick wall, polyurethane tubing, formulated to TAC specifications. It resists kinking and provides a tight seal under a wide range of environmental conditions. **ONLY 2803 SERIES TAC PNEUMODULAR TUBING** is recommended for use in TAC Pneumodular panels.

Piping jumpers are cut to length when piping the panel. Care should be taken to use a long enough piece of tubing in order to avoid kinking on short connections. In-line restrictors (21-153) may be utilized by inserting them into the appropriate jumpers where necessary. Socket ports that have a signal or main air supply to them, but are not needed for piping connections, must be plugged using 22-140 plugs.

External tubing connections to the TAC Pneumodular panel are done easily and neatly by utilizing a pneumatic terminal Strip (22-142). Tubing connections are numbered 1 thru 10 on one side and 11 thru 20 on the other side in case it is necessary to utilize more than 10 connections per panel. The 22-142 is mounted to the panel in the appropriate position to allow access for external connections, see Figure 6.

Tubing connections to the socket end may be made by removing the pre-installed plug from the appropriate port and installing a connector fitting (22-141). Connections from the tubing connector to the terminal strip are made utilizing the

2803 Series TAC Pneumodular tubing. Connections from the terminal strip to the external devices and equipment may be made with standard 2802 Series "FR" type polyethylene tubing.

Table-6 Piping Ordering Information.

TAC Wholesale Number	Replaces Model	Description
2803-100	MCS-Tubing	100 Ft. Roll
2803-500	MCS-Tubing	500 Ft. Roll
21-153	N100-2501	In-Line Restrictor
22-140	MCS-SC	Sealing Plug
2890-540	MCS-SC	Sealing Plugs Quantity Package (250)
22-141	MCS-TC	Tubing Connector
2890-541	MCS-TC	Tubing Connectors Quantity Package (50)
22-142	MCS-PTS	Pneumatic Terminal Strip

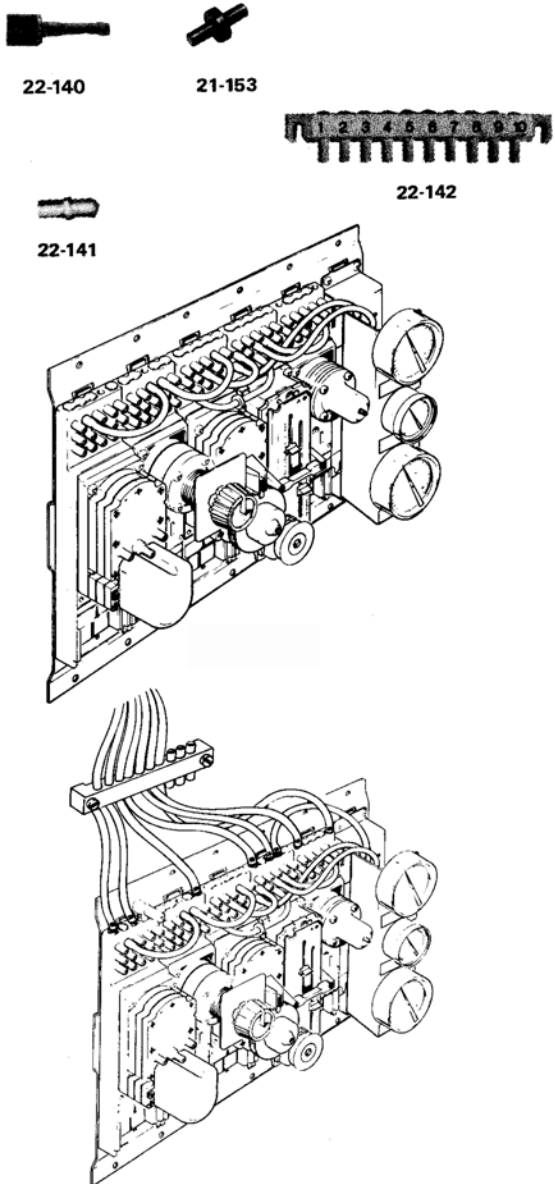

Figure-6 Piping Instructions.

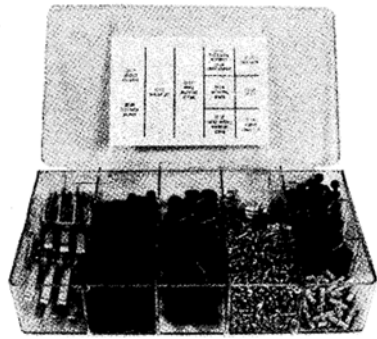

Figure-7 2890-500 Parts Kit.

The 2890-500 TAC Pneumodular Parts Kit, Figure 7, consists of an assortment of the necessary items to assemble a TAC Pneumodular panel. The plastic case provides a convenient method of storage for these items.

Table-7 2890-500 TAC Pneumodular Parts Kit.

Kit Includes:	
5	22-122 Electrical Contact Assembly
25	22-130 Plug Strip
250	22-140 Sealing Plug
50	22-133 Gasket
200	22-134 Screw
200	22-135 Screw
5	22-136 Electrical Barrier
5	22-137 Check Valve Assembly
5	22-138 Gauge Adapter
10	22-139 Gauge Mounting Fitting
50	22-141 Tubing Connector

Copyright 2007, TAC
All brand names, trademarks and registered
trademarks are the property of their respective
owners. Information contained within this
document is subject to change without notice.

TAC
1354 Clifford Avenue
P.O. Box 2940
Loves Park, IL 61132-2940

F-24606-1



www.tac.com

