

Pneumatic Humidity Transmitter General Instructions

For proportional humidity control, used with RKS series receiver-controllers. May be used with calibrated gauges for continuous humidity indication at any local or remote position.

The humidity transmitter uses a highly sensitive nylon humidity element.

SPECIFICATIONS

Sensing Span: 80% Rh; 10-90% Rh range (non-adjustable).

Output Air Signal: 3 to 15 psig.

Maximum Safe Temperature: 150 °F.

Air Connections: HKS-2033 has 1/4" O.D. plastic tubing; HKS-5033 has 5/32" dia. spring reinforced plastic tube. Air consumption for sizing air compressor is .024 standard cubic feet per minute. Air capacity for sizing air mains is 50 standard cubic inches per min.

Dimensions:

Duct type, 4-3/16" high x 4" wide x 2-1/16" deep. Tube mounting hole diameter is 1-3/8"; tube insertion length is 4-1/4".

Wall mount, 4-3/8" high x 2-3/4" wide x 1-5/8" deep.

Order fittings separately for type of wall construction.

Options: None.

Table-1 Model Chart.

Part Number	Action	Mounting	Range	Direct Acting Output Signal (psig)
HKS-2033	Direct	Duct	Non-Adj. 10-90% Rh	3-15
HKS-5033	Acting	Wall		

Accessories:

- AT-504 Plaster hole cover (small)
- AT-505 Surface mounting base
- AT-506 Pneumatic wall box fitting (two tubes) used for mounting AT-532-111-1-01 under cover of HKS-5033
- AT-1103 Wire Guard
- AT-1104 Cast aluminum guard
- AT-1105 Plastic guard
- AT-1155 Plastic guard
- AT-1165 Plastic guard
- AT-532-111-1-01 .0075 tee restrictor for 5/32" plastic tubing
- AT-532-222-1-01 .0075 tee restrictor for 1/4" plastic tubing
- AT-532-098-1-01 .0075 tee restrictor (white)
- AT-533-67 Adaptor 1/4" plastic tubing to 3/16" copper or 1/4" copper with 1/4" solder coupling (not included)

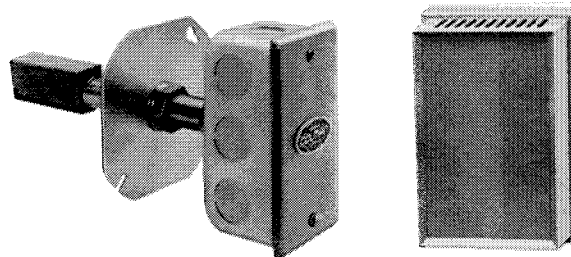

- AT-533-101 Adaptor 1/4" plastic to 5/32" plastic
- AT-533-127 Adaptor 3/16" copper or 1/4" copper with 1/4" solder coupling (not included) to 5/32" plastic
- AKS-6281 Stem mounted back connected humidity receiver gauge
- AKS-9081 Flush panel mounted with U clamp humidity receiver gauge

INSTALLATION

HKS-5033 Room Transmitter

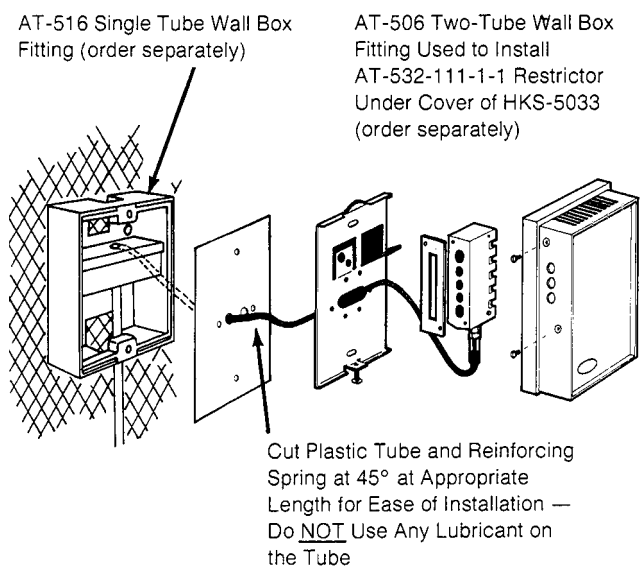

Figure-1 Mounting of HKS-5033 on AT-506 or AT-516 Wall Box Fitting.

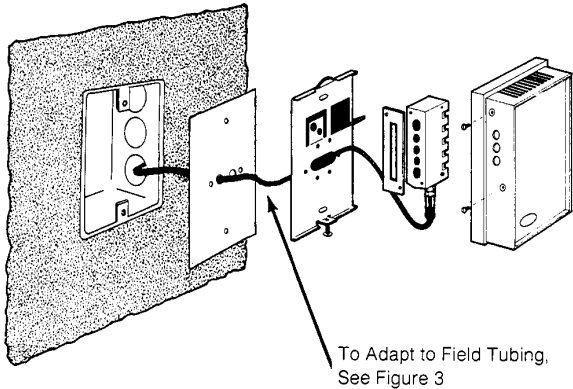

Figure-2 Mounting of HKS-5033 to Electrical Box.

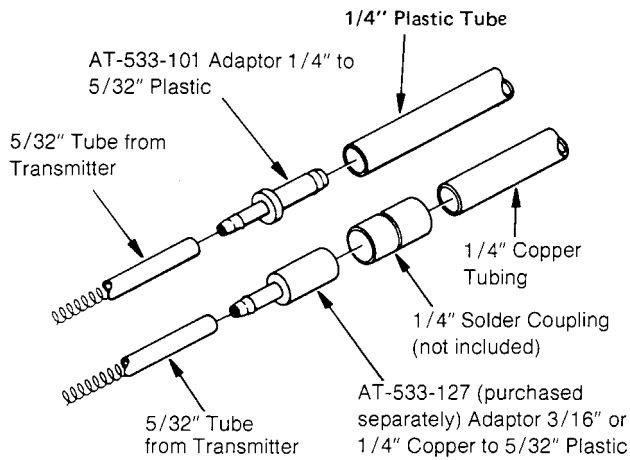
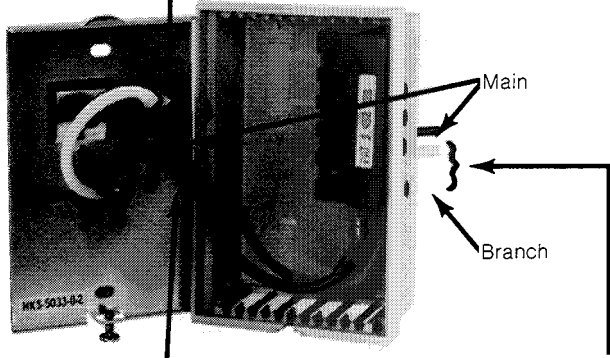

Figure-3 Adapting HKS-5033 5/32" Tube to Field Tubing.

AT-532-111-1-1 Tee Restrictor for 5/32" Plastic Tubing (order separately)



Cut Existing Tube Approximately 5" from Base of Transmitter
5/32" Plastic Tubes & Springs Provided with AT-532-111-1-1
Figure-4 Installation of Restrictor Under Cover of HKS-5033.

HKS-2033 Duct Transmitter

The duct transmitter is mounted directly to the duct with the sensing element tube located at the top. See Figure 5 for duct transmitter mounting dimensions. Tubing connection to air is made by using adaptors for plastic tubing or copper tubing. A strain relief and bushing is provided to secure plastic tubing where it enters the housing.

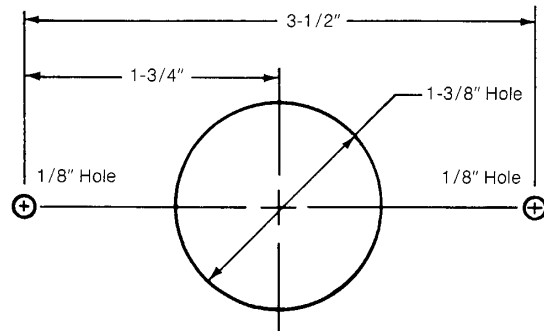

Figure-5 Duct Transmitter Mounting.

1. Remove cover.
2. Remove a knockout and insert a metal bushing. Flatten tabs.
3. Connect tubing. Connect the field tubing and unit plastic tubing with a 1/4-inch barbed coupling. Push the tubing and fitting into the box. Clamp the strain relief around the field tubing and insert into a metal bushing.

Copper field tubing: See Figure-6 for installation. Strain relief cannot be used.

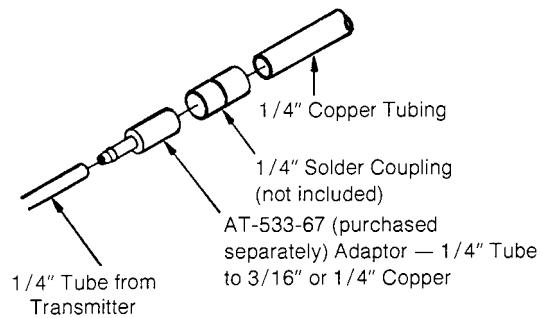

Figure-6

4. Replace cover.

CHECKOUT

1. Connect the transmitter(s) to the calibration box, AKS-100 (current box) or SYZE-12875 (obsolete box) per Figures 7 through 11.
2. Move toggle switches to the UP (transmitter) position.
3. After making sure the transmitters are sensing a stable humidity, measure the condition at the transmitter with an accurate measuring device.

- Note reading on calibration box gauges for specific range of transmitter used, compared to condition measured at the transmitter.

Readings should be within $\pm 6\%$ Rh on an 80% Rh span transmitter. If readings are not within these limits, replace the transmitter.

- Adjust all permanent receiver gauges to match the condition as measured with the accurate measuring device (not calibration box gauge).
- For calibration of receiver-controller, see General Instruction sheet for the receiver-controller.

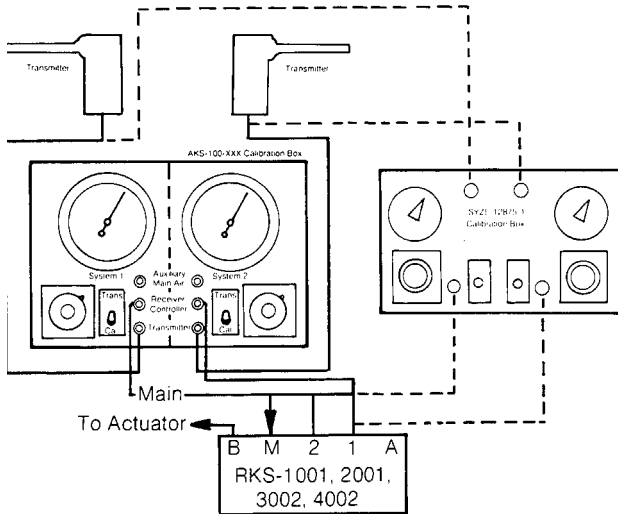

Figure-7 RKS-1001, 2001, 3002, 4002 Receiver-Controller with Transmitter Located Less than 200 Feet from Controller.

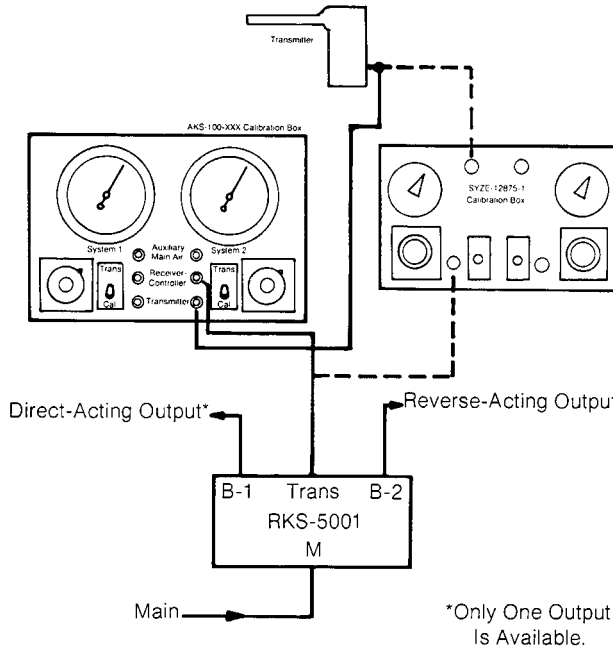

Figure-8 RKS-5001 Receiver-Controller with Transmitter Located Less Than 20 Feet from Controller.

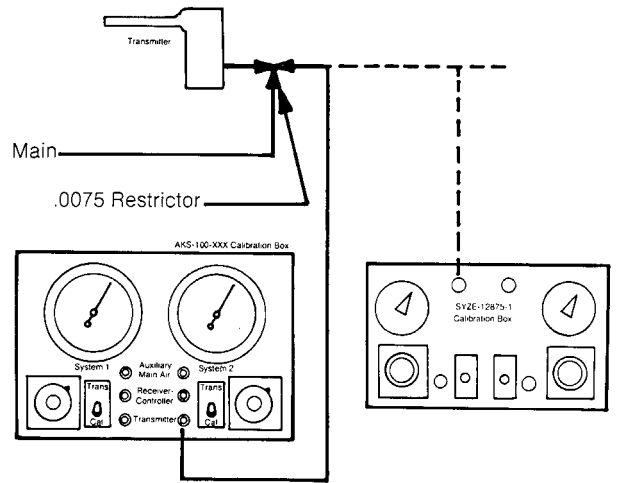

Figure-9 Indication Only: Transmitter Located Less Than 200 Feet from Remote Restrictor and Transmitter Less Than 1000 Feet from Receiver Gauge.

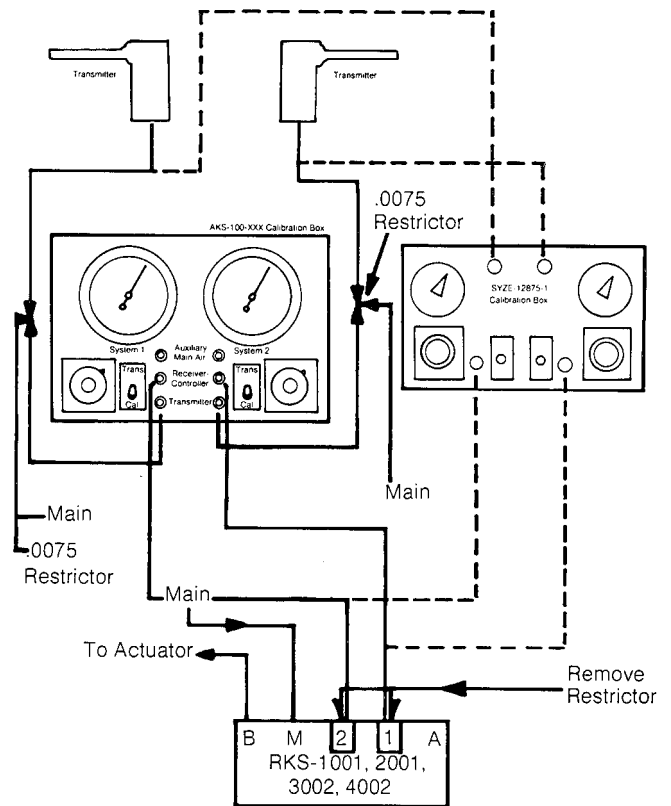

Figure-10 RKS-1001, 2001, 3002, 4002 Receiver-Controller with Transmitter Located Less Than 200 Feet from Remote Restrictor and Transmitter Located Less Than 1000 Feet from Receiver-Controller.

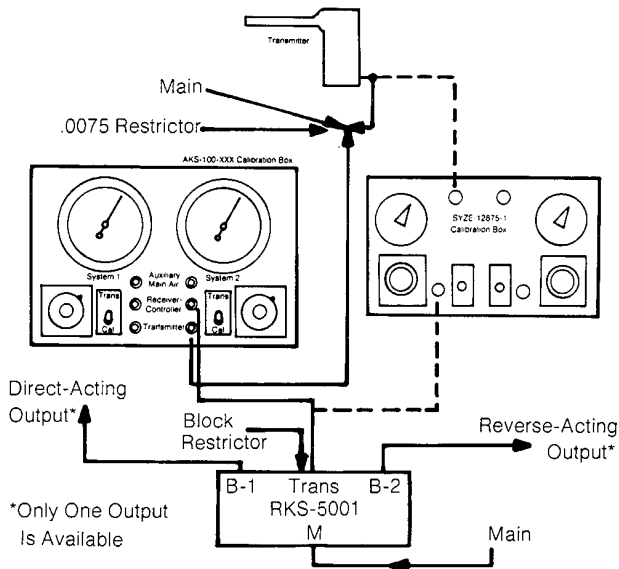

Figure-11 RKS-5001 Receiver-Controller with Transmitter Located Less Than 200 Feet from Remote Restrictor and Transmitter Located Less Than 1000 Feet from Receiver-Controller.

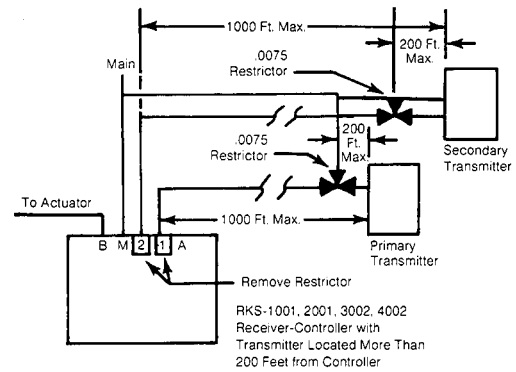
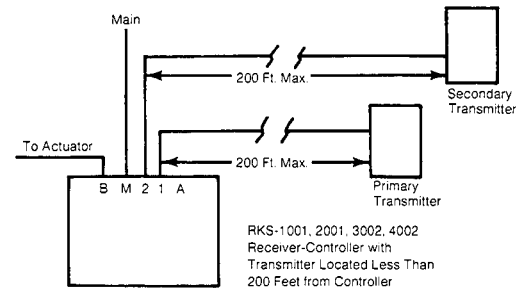

Figure-13 Typical Piping with RKS-1001, 2001, 3002, 4002 Receiver-Controller.



RUN/ADJUST

No adjustments are required on the transmitter.

MAINTENANCE

The unit requires no maintenance under normal conditions

REPAIR

Field repair is not recommended. If the system is not operating correctly and the reason is traced to the transmitter, it should be replaced.

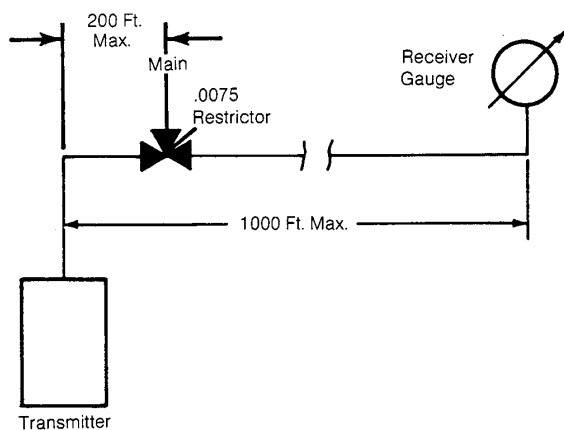
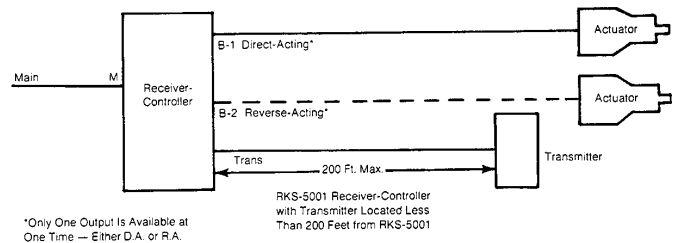

Figure-12 Typical Piping for Indication Only.

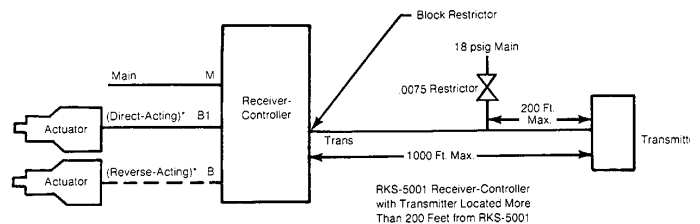

Figure-14 Typical Piping with RKS-5001 Receiver-Controller.

On October 1st, 2009, TAC became the Buildings business of its parent company Schneider Electric. This document reflects the visual identity of Schneider Electric, however there remains references to TAC as a corporate brand in the body copy. As each document is updated, the body copy will be changed to reflect appropriate corporate brand changes.

Copyright 2009, Schneider Electric
All brand names, trademarks and registered trademarks are the property of their respective owners. Information contained within this document is subject to change without notice.

Schneider Electric
1354 Clifford Avenue
P.O. Box 2940
Loves Park, IL 61132-2940

www.schneider-electric.com/buildings

Schneider
Electric