

## 2-1/2" to 6" 125 psi Flanged Universal Three-Way Mixing/Diverting Valves General Instructions

### Application

VB-8303 series three-way valves control hot or chilled water in heating or air conditioning systems. These valves may be piped as mixing valves with 2 inlets ("A" and "B") and one outlet ("AB") or as diverting valves with one inlet ("AB") and two outlets ("A" and "B"). They are used for two-position or proportional control applications. Valve assemblies require an electric/electronic or pneumatic actuator and valve linkage that may be purchased separately or as part of a complete factory valve assembly.

These valves will also operate satisfactorily as two-way angle valves if either end (side) port is closed off.

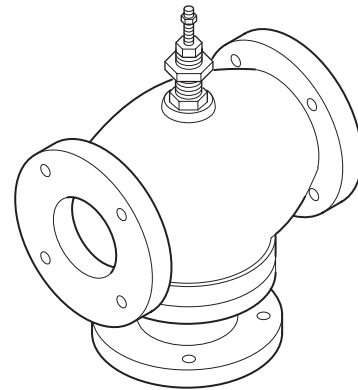

Typical of VB-8303-0-5-P  
2-1/2" to 6"



**Danger:** Do not use for combustible gas applications. The VB-8303 series valves are not rated for combustible gas applications, and if used in these applications, gas leaks and explosions may result.

**Caution:** Piping must always use the "AB" (bottom) port as the common. Whether diverting or mixing, the "AB" port is the common. Pipe accordingly.

### Features

- Valve sizes 2-1/2" to 6".
- Excellent close-off capability up to 35 psi.
- Meets ANSI III seat leakage specifications.
- 125 psig pressure rating per ANSI Standards (B16.1-1993) for flanged cast iron bodies.
- Self-adjusting spring-loaded TFE/EPDM packing.
- Expanded operating temperatures 20° to 281°F

## Applicable Literature

F-Number	Description	Audience	Purpose	
F-27199	Vx-8xxx Series Selection Guide	<ul style="list-style-type: none"> <li>– Sales Personnel</li> <li>– Application Engineers</li> <li>– Installers</li> <li>– Service Personnel</li> <li>– Start-up Technicians</li> </ul>	Provides features, specifications, mounting dimensions, and other criteria useful to the selection of Vx-8xxx series valves.	
F-27383	TAC Pneumatic Products Catalog		Provides a comprehensive listing of TAC component products, describing their features and specifications, and provides other reference material useful to their selection.	
F-27253	AV-497 Valve Linkage for MK-6811 and MK-6911 General Instructions		Describes the valve linkage's features, specifications, and possible applications. Provides step-by-step mounting instructions.	
F-27082	AV-607 and AV-609 TAC DuraDrive Linkages for 2-1/2" to 6" Valves General Instructions		<ul style="list-style-type: none"> <li>– Sales Personnel</li> <li>– Application Engineers</li> <li>– Installers</li> <li>– Service Personnel</li> <li>– Start-up Technicians</li> </ul>	<p>Describes the actuator's features, specifications, and possible applications.</p>
F-24842	AV-672 Electric/Electronic Valve Linkage Kit General Instructions			
F-26642	MA40-704x, MA4x-707x, MA4x-715x TAC DuraDrive™ Series Spring Return Two-Position Actuators General Instructions			
F-13895	MK-6xxx Series Proportional Pneumatic Actuators General Instructions			
F-26644	MF4x-7xx3, MF4x-7xx3-50x TAC DuraDrive Series Spring Return Floating Actuator General Instructions			
F-26744	MF41-6343 TAC DuraDrive Series Non-Spring Return Direct Coupled Actuator General Instructions			
F-24732	MF-631x3, MF-63123-x11 Floating Valve Actuator General Instructions			
F-26745	MS40-634x TAC DuraDrive Series Non-Spring Return Direct Coupled Actuator General Instructions			
F-27120	Mx1-720x TAC DuraDrive Series Actuator General Instructions			
F-26080	EN-205 Water System Guidelines	<ul style="list-style-type: none"> <li>– Application Engineers</li> <li>– Installers</li> <li>– Service Personnel</li> <li>– Start-up Technicians</li> </ul>	Provides treatment guidelines for water and steam systems.	

# SPECIFICATIONS

Table-1 Specifications/Models

Specifications			Valve Body Series VB-8303-0-5-P
Service			Chilled or Hot Water
Flow Characteristics (Figure-1)			Modified Linear (May Be Piped as Mixing or Diverting)
Sizes			2-1/2" to 6"
Type of End Fitting			125 psi Flanged
Valve Materials	Body		Cast Iron
	Seat		Forged Brass
	Stem		Stainless Steel
	Plug		Forged Brass
	Packing		Spring-loaded TFE/EPDM
	Seat Ring		None
ANSI Pressure Class (Figure-2)			125 psi Flanged (up to 200 psig below 150°F)
Allowable Control Media Temperature			20 to 281 °F (-7 to 138 °C)
Close-off Pressure <sup>a</sup>			35 psi (241 kPa)
Valve Size	C <sub>v</sub> Rating <sup>b</sup>	k <sub>vs</sub> Rating <sup>b</sup>	Complete Valve Body Part Number
2-1/2"	80 <sup>c</sup>	69 <sup>c</sup>	VB-8303-0-5-12
	95 <sup>d</sup>	82 <sup>d</sup>	
	115 <sup>e</sup>	99 <sup>e</sup>	
3"	110 <sup>c</sup>	95 <sup>c</sup>	VB-8303-0-5-13
	120 <sup>d</sup>	104 <sup>d</sup>	
	120 <sup>e</sup>	104 <sup>e</sup>	
4"	190 <sup>f</sup>	164 <sup>f</sup>	VB-8303-0-5-14
5"	290 <sup>f</sup>	251 <sup>f</sup>	VB-8303-0-5-15
6"	500 <sup>f</sup>	433 <sup>f</sup>	VB-8303-0-5-16

<sup>a</sup> Exceeding maximum close-off pressure voids product warranty. Do not exceed maximum operating pressure differential. See Vx-8xxx Selection Guide, F-27199 for maximum operating pressure differentials.

<sup>b</sup>  $C_v = \frac{gpm}{\sqrt{\Delta P}}$  (where  $\Delta P$  is measured in psi)       $k_{vs} = C_v / 1.156$        $k_{vs} = \frac{m^3/h}{\sqrt{\Delta P}}$  (where  $\Delta P$  is measured in bar; 1 bar = 100 kPa)

<sup>c</sup> Mixing configuration, flow from either A or B to AB ports. See Figure-3 on page 9.

<sup>d</sup> Diverting configuration, flow AB to A ports. See Figure-4 on page 9.

<sup>e</sup> Diverting configuration, flow AB to B ports. See Figure-4 on page 9.

<sup>f</sup> All flow configurations.

## Maximum Operating Pressure Differential

The maximum operating pressure differential is dependent on the size of the valve and the actuator. See the *Vx-8xxx Selection Guide*, F-27199, for maximum operating pressure differential.

## Normal Position of Valve Assembly

For a valve assembly (valve, linkage, and actuator) to have a normal position, the actuator must be of the spring return type. See Table-2 for compatible spring return and non-spring return actuators and their normal positions.

**Table-2 Typical Compatible Actuators and Linkages**

Actuator Series	Control Signal Type	Spring Return	Required Valve Linkage		Normal Position
			2-1/2" to 5" Valves	6" Valves	
MA61-7200	Two Position 120 Vac	Yes	None <sup>a</sup>	—	Stem Up
MA61-7201	Two Position 230 Vac	Yes	None <sup>a</sup>	—	Stem Up
MA61-7203	Two Position 24 Vac	Yes	None <sup>a</sup>	—	Stem Up
MA41-7150	Two Position 120 Vac	Yes	AV-607	AV-609	Stem Up <sup>b</sup>
MA41-7151	Two Position 230 Vac	Yes	AV-607	AV-609	Stem Up <sup>b</sup>
MA41-7153	Two Position 24 Vac	Yes	AV-607	AV-609	Stem Up <sup>b</sup>
MA40-7170	Two Position 120 Vac	Yes	AV-607	AV-609	Stem Up <sup>b</sup>
MA40-7171	Two Position 230 Vac	Yes	AV-607	AV-609	Stem Up <sup>b</sup>
MA40-7173	Two Position 24 Vac	Yes	AV-607	AV-609	Stem Up <sup>b</sup>
MF-63103	Floating 24 Vac	No	AV-672	—	None
MF-63123	Floating 24 Vac <sup>c</sup>	No	AV-672	—	None
MF-63123-211	Proportional Vdc <sup>d</sup>	No	AV-672	—	None
MF-63123-411	Proportional mAdc <sup>e</sup>	No	AV-672	—	None
MF41-6343	Floating 24 Vac	No	—	AV-609	None
MF41-7153		Yes	AV-607	AV-609	Stem Up <sup>b</sup>
MF40-7173			None <sup>a</sup>	—	Stem Up
MF61-7203			AV-497	—	Stem Up
MK-6811 <sup>f</sup>	Pneumatic 5 to 10 psig <sup>f</sup>	Yes	—	AV-497	Stem Up
MK-6911 with AK-42309-500 <sup>g</sup>	Pneumatic 5 to 10 psig <sup>g</sup>	Yes	—	AV-497	Stem Up
MS41-7153	Proportional 2 to 10 Vdc <sup>h</sup>	Yes	AV-607	AV-609	Stem Up
MS40-7170	Proportional 2 to 10 Vdc <sup>h</sup>	Yes	AV-607	AV-609	Stem Up <sup>b</sup>
MS40-7171					
MS40-7173					
MS41-6340	Proportional 2 to 10 Vdc <sup>h</sup>	No	—	AV-609	None
MS41-6341					
MS41-6343		Yes	None <sup>a</sup>	—	Stem Up <sup>a</sup>
MS61-7203					

<sup>a</sup> Linkage integral to actuator.

<sup>b</sup> As shipped from factory. May be field configured for normally stem down.

<sup>c</sup> MFC-8000 and MFC-420 plug-in control modules may be field installed for proportional control.

<sup>d</sup> MFC-8000 control module factory installed, set for 6 to 9 Vdc, 1" (25 mm) stroke.

<sup>e</sup> MFC-420 control module factory installed, set for 4 to 20 mAdc, 1" (25 mm) stroke.

<sup>f</sup> AK-42309-500 positive positioner may be ordered separately and field adjusted for other ranges. Order a VK4 valve assembly for factory-installed positive positioner.

<sup>g</sup> AK-42309-500 positive positioner must be used with MK-6911 on 6" VB-8303. Order separately. May be field adjusted for other ranges. Order a VK4 valve assembly for factory-installed positive positioner.

<sup>h</sup> May be field configured for 4-20 mAdc.

### Flow Characteristics

When piped as a mixing valve, flow from either of the two inlet ports to the outlet is approximately linear, which means that the total flow from the outlet is almost constant over the stroke of the valve stem. See Figure-1 for typical flow characteristics of VB-8303 series valve bodies.

When piped as a diverting valve, flow from the inlet port to either of the two outlet ports is approximately linear, which means that the total flow to the inlet is almost constant over the stroke of the valve stem.

As either port begins to open, it is characterized similar to an equal percentage curve to enhance system stability.

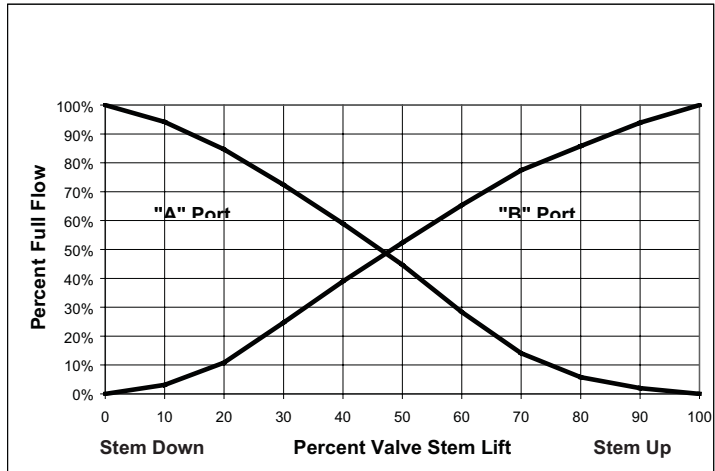

Figure-1 Typical Modified Linear Flow Characteristics

### Rangeability

Rangeability is the ratio of rated flow to the minimum controllable flow through a valve. The nominal rangeability for VB-8303 series valves is greater than 100:1.

### Temperature/Pressure Ratings

See Figure-2 for temperature and pressure ratings. Consult the appropriate actuator General Instructions sheet for the effect of ambient temperature on specific actuators. Ratings conform with published values and disclaimer.

#### VB-8303-0-5-P (Flanged Cast Iron Body)

**Standards:** ANSI B16.1–1993

**Materials:** ASTM A126-93 Class B

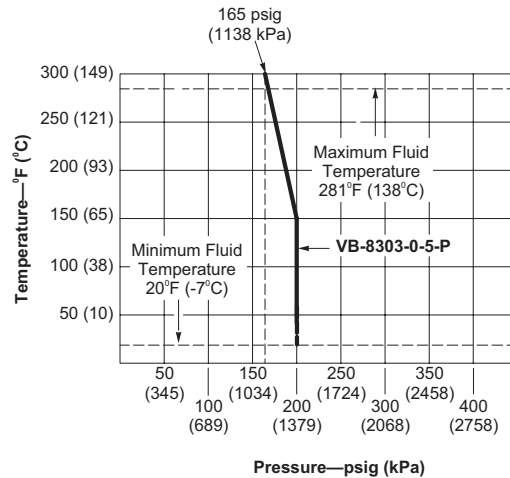

Figure-2 Temperature and Pressure Ratings for VB-8303 Series Valve Bodies

# VALVE SIZING AND SELECTION

## Water

### Flow Coefficient (Cv)

Sizing a valve requires selecting a flow coefficient ( $C_v$ ), which is defined as the flow rate in gallons per minute (gpm) of 60°F water that will pass through the fully open valve with a 1 psi pressure drop ( $\Delta p$ ). It is calculated according to the formulas shown in “ $C_v$  Equation for Water”.

Since the flow rate through the heat exchanger is usually specified, the only variable normally available in sizing a valve is the pressure drop. The following information can be used to determine what pressure drop to use in calculating a valve  $C_v$ . Using the calculated  $C_v$ , consult Table-4 or Table-5 to select the valve body with the nearest available  $C_v$ .

---

**Caution:** Be sure that the anticipated pressure drop across the valve will not exceed the close-off pressure rating and the maximum pressure differential rating listed in the *Vx-8xxx Selection Guide*, F-27199.

---

### Two-position

Two-position control valves are normally selected “line size” to keep pressure drop at a minimum. If it is desirable to reduce the valve below line size, then 10% of “available pressure” (that is, the pump pressure differential available between supply and return mains with design flow at the valve location) is normally used to select the valve.

### Proportional to Bypass Flow

Proportional mixing valves used to bypass flow (Figure-6) are piped on the outlet side of the load to throttle the water flow through the load and therefore control heat output of the load. These valves are usually selected to take a pressure drop equal to at least 50% of the “available pressure.” As “available pressure” is often difficult to calculate, the normal procedure is to select the valve using a pressure drop at least equal to the drop in the coil or other load being controlled (except where small booster pumps are used) with a minimum recommended pressure drop of 5 psi (34 kPa). When the design temperature drop is less than 60°F (33°C) for conventional heating systems, higher pressure drops across the valve are needed for good results (Table-3).

**Table-3 Conventional Heating System**

Design Temperature Load Drop °F (°C)	Recommended Pressure Drop <sup>a</sup> (% of Available Pressure)	Multiplier on Load Drop
60 (33) or More	50%	1 x Load Drop
40 (22)	66%	2 x Load Drop
20 (11)	75%	3 x Load Drop

<sup>a</sup> Recommended minimum pressure drop = 5 psi (34 kPa).

**Secondary Circuits with Small Booster Pumps:** 50% of available pressure difference (equal to the drop through load, or 50% of booster pump head).

### Proportional to Blend Water Flows

Proportional valves used to blend two water flows (Figure-7 and Figure-8) control the heat output by varying the water temperature to the load at constant flow. These valves do not require high pressure drops for good control results. They can be sized for a pressure drop of 20% of the “available pressure” or equal to 25% of the pressure drop through the load at full flow.

### Water Table

See Table-4 for water capacity of VB-8303 series valves.

**Table-4 Water Capacity in Gallons Per Minute for VB-8303 Series<sup>a</sup>**

Valve Body Part Number	C <sub>v</sub> Rating	Differential Pressure (ΔP in psi)														
		1	2	3	4	5	6	7	8	9	10	15	20	25	30	35
VB-8303-0-5-12	80	80	113	139	160	179	196	212	226	240	253	310	358	400	438	473
	95	95	134	165	190	212	233	251	269	285	300	368	425	475	520	562
	115	115	163	199	230	257	282	304	325	345	364	445	514	575	630	680
VB-8303-0-5-13	110	110	156	191	220	246	269	291	311	330	348	426	492	550	602	651
	120	120	170	208	240	268	294	317	339	360	379	465	537	600	657	710
VB-8303-0-5-14	190	190	269	329	380	425	465	503	537	570	601	736	850	950	1041	1124
VB-8303-0-5-15	290	290	410	502	580	648	710	767	820	870	917	1123	1297	1450	1588	1716
VB-8303-0-5-16	500	500	707	866	1000	1118	1225	1323	1414	1500	1581	1936	2236	2500	2739	2958

<sup>a</sup> Refer to Table-1 for details on multiple Cv ratings.

### C<sub>v</sub> Equation for Water

$$C_v = \frac{gpm}{\sqrt{\Delta P}} \quad \Delta P = \left(\frac{gpm}{C_v}\right)^2 \quad gpm = C_v \sqrt{\Delta P}$$

Where:

C<sub>v</sub> = Coefficient of flow.

gpm = Flow rate of water that will pass through fully open valve, measured in U.S. gallons per minute (60 °F (15.6 °C) water).

ΔP = Differential pressure (pressure drop), measured in psi.

### Cavitation Limitations on Valve Pressure Drop

A valve selected with too high a pressure drop can experience erosion of discs and/or wire drawing of the seat. In addition, cavitation can cause noise, damage to the valve trim (and possibly the body), and choke the flow through the valve.

Do not exceed the maximum differential pressure (pressure drop) for the valve selected.

The following formula can be used on higher-temperature water systems, where cavitation could be a problem, to estimate the maximum allowable pressure drop across the valve:

$$P_m = 0.5 (P_1 - P_v)$$

Where:

P<sub>m</sub> = Maximum allowable pressure drop

P<sub>1</sub> = Absolute inlet pressure (psia)

P<sub>v</sub> = Absolute vapor pressure (psia) (refer to Table-5)

---

**Note:** Add 14.7 psi to the gauge supply pressure to obtain the absolute pressure value.

---

For example, if a valve is controlling 200°F water at an inlet pressure of 18 psig, the maximum pressure drop allowable would be:

$$P_m = 0.5 [(18 + 14.7) - 11.53] = 10.6 \text{ psi}$$

(Vapor pressure of 200°F water is 11.53 psi.)

Therefore, if the pressure drop for this valve is less than 10.6 psi, cavitation should not be a problem.

Systems where cavitation is shown to be a problem can sometimes be redesigned to provide lower inlet velocities. Valves having harder seat materials should be furnished if inlet velocities cannot be lowered.

**Table-5 Vapor Pressure of Water Table**

Water Temp. (°F)	Vapor Pressure (psia)	Water Temp. (°F)	Vapor Pressure (psia)	Water Temp. (°F)	Vapor Pressure (psia)	Water Temp. (°F)	Vapor Pressure (psia)
40	0.12	90	0.70	140	2.89	190	9.34
50	0.18	100	0.95	150	3.72	200	11.53
60	0.26	110	1.28	160	4.74	210	14.12
70	0.36	120	1.69	170	5.99	220	17.19
80	0.51	130	2.22	180	7.51	230	20.78

## Additional Valve Sizing Information

For additional valve sizing information, see the *Vx-8xxx Selection Guide*, F-27199.

## INSTALLATION

### Inspection

Inspect the package for damage. If damaged, notify the appropriate carrier immediately. If undamaged, open the package and inspect the device for obvious damage. Return damaged products.

### Requirements

- Tools (not provided): Wrenches.
- Training: Installer must be a qualified, experienced technician
- Appropriate accessories

---

**Caution:**

- Install the valve with the flow in the proper direction. See Figure-3 and Figure-4.
  - Do not exceed the ratings of the device.
  - Avoid locations where excessive moisture, corrosive fumes, or vibration are present.
- 

### Mounting

1. The valve should be mounted in a weather-protected area in a location that is within the ambient limits of the actuator. When selecting a location, allow sufficient room for valve linkage, actuator, and other accessories and for service of the product.
2. The preferred mounting position for the valve is with the valve stem vertical above the valve body. Avoid mounting the valve so that the valve stem is below horizontal.
3. Pipe the valves with two inlets ("A" and "B" ports) and one outlet ("AB" port) for mixing applications. Pipe with one inlet ("AB") and two outlets ("A" and "B") for diverting applications. See Figure-3 and Figure-4.

---

**Note:** "AB" is the valve's bottom port. A label on the side of the valve provides port identification.

---

### Flanged Valve Bodies

The VB-8303-0-5-P series flanged valve bodies conform to ANSI B16.1 Class 125. The companion flanges (not provided) should be the same specification as the valve. The 125 psi flanges have plain flat faces and should not be bolted to a raised faced flange.

1. All parts should be clean to assure tight seals.
2. The pipe with the companion flanges installed must be properly supported and aligned. Be sure the companion flange is flush with the face of the valve body flange and lined up squarely.
3. Use a gasket material (not provided) that is recommended for the medium being handled.

---

**Caution:** Do not apply pipe dope to the valve flange, gasket, or companion flange.

---

4. See Figure-5 for flange and flange bolt details. Figure-5 also shows the proper way a flanged valve should be mounted.



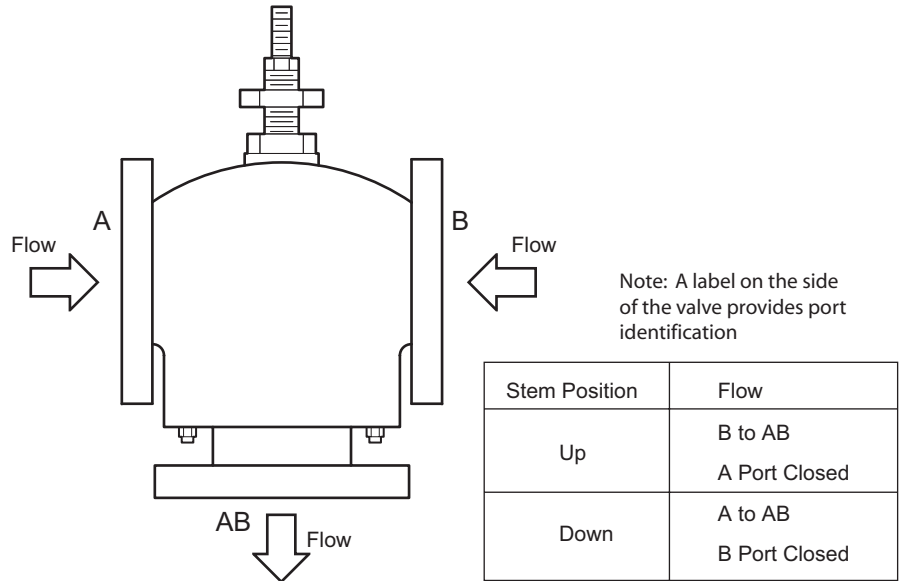

Figure-3 VB-8303 Piped as Mixing Valve

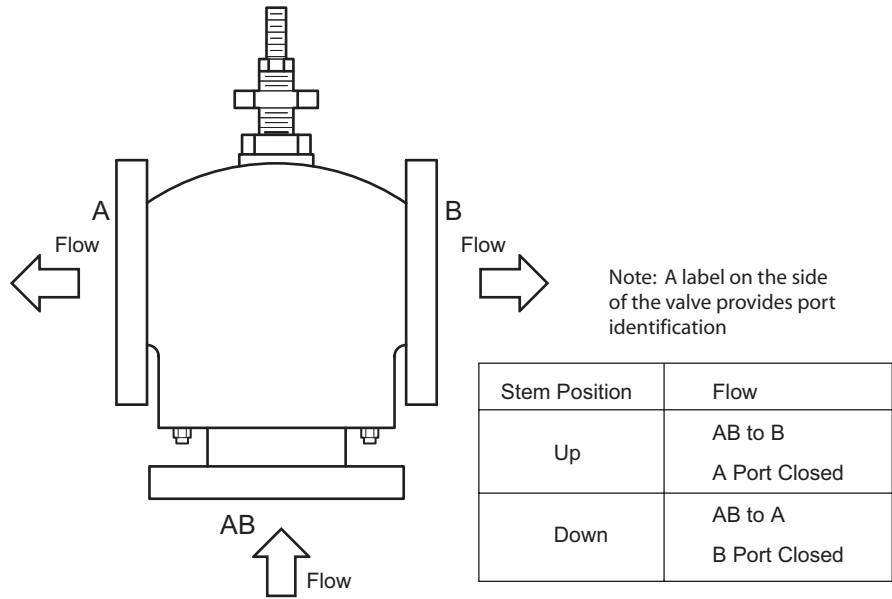

Figure-4 VB-8303 Piped as Diverting Valve

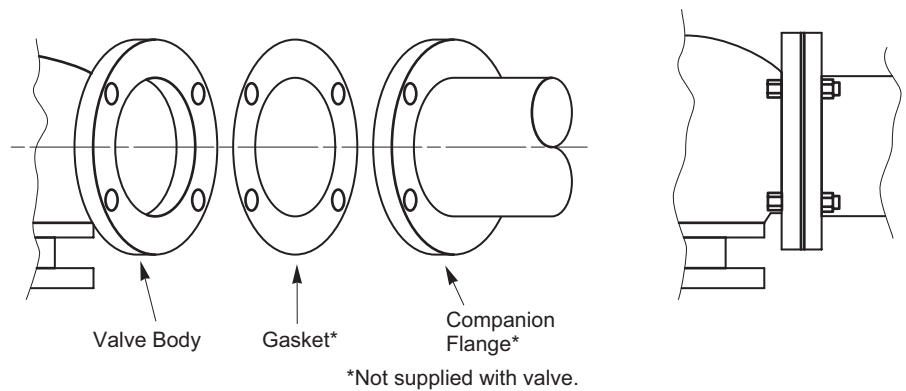

Figure-5 Installation of Flanged End Valves

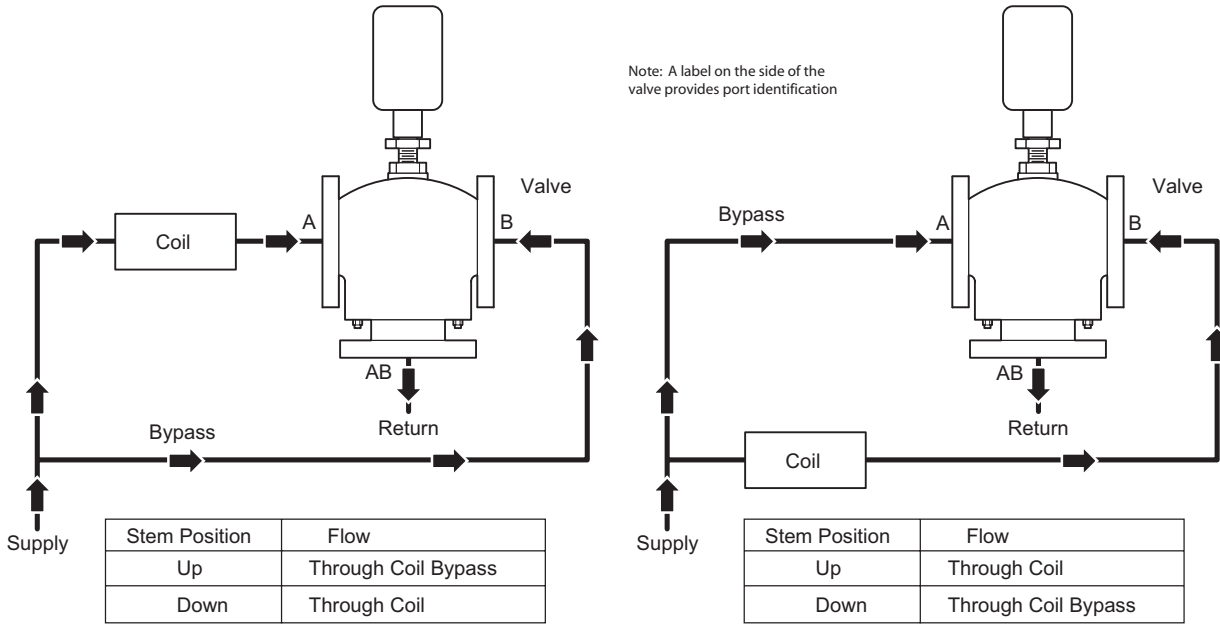

Figure-6 VB-8303 Typical Piping for Control of Heating or Cooling Coil

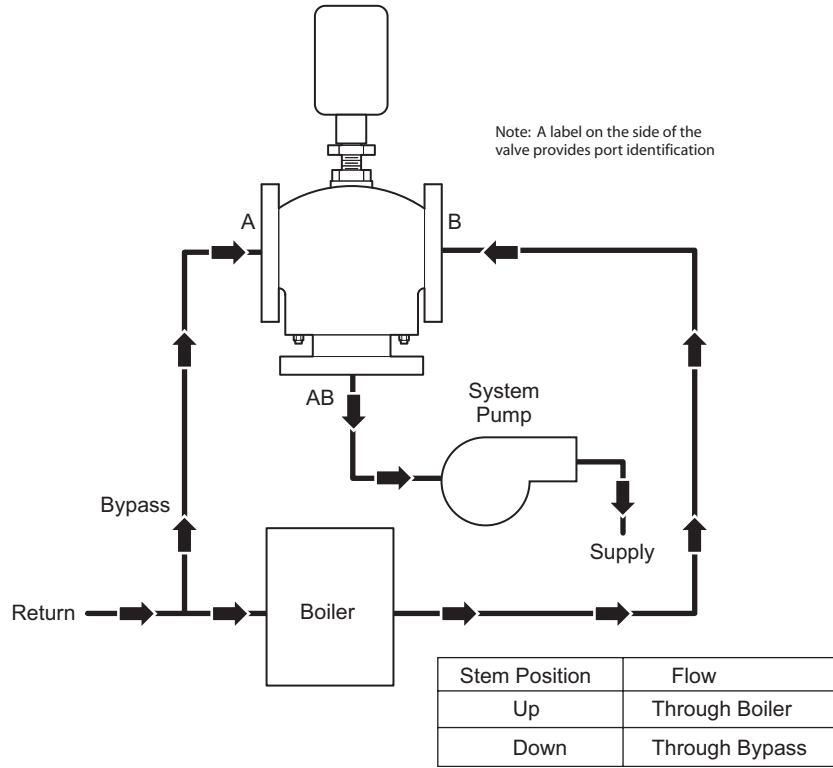

Figure-7 VB-8303 Typical Boiler Hot Water Reset

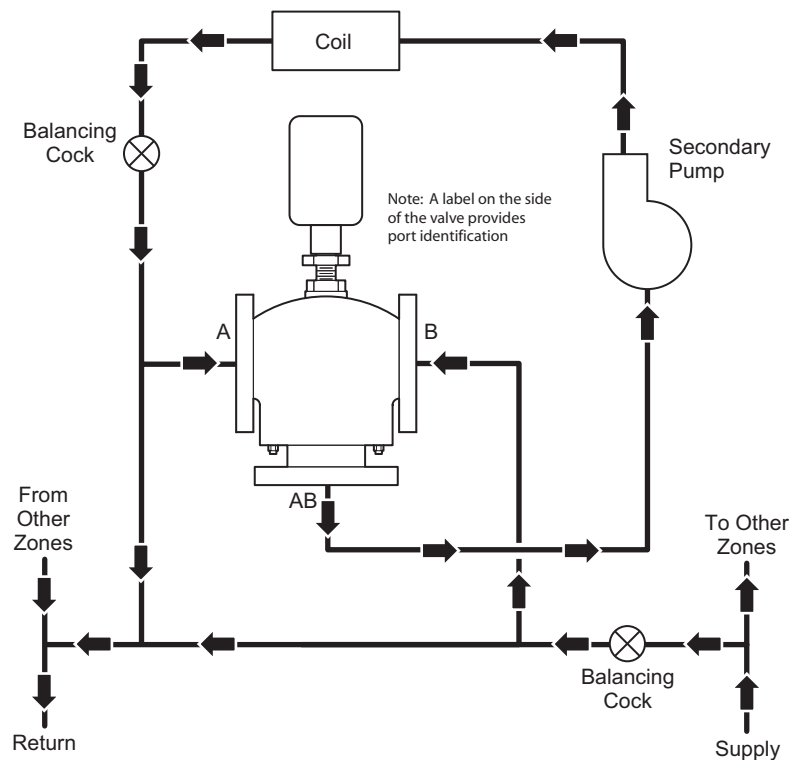

Figure-8 VB-8303 Typical Primary-Secondary Piping

## CHECKOUT

1. Make sure the valve stem operates smoothly before installing the valve linkage and the actuator. Initial breakaway force can be expected.
2. If the stem does not operate smoothly, it may indicate that the valve stem was bent by rough handling. These conditions may require valve replacement.
3. After the piping is under pressure, check the valve body and the connections for leaks.
4. After the valve linkage and the actuator are installed, check their operation.
  - a. Drive the actuator and run the valve to the stem down position. Make sure the linkage and valve stem move freely. Consult Figure-3 (mixing) or Figure-4 (diverting) for proper flow in the stem down position.
  - b. Drive the actuator and valve to the stem up position. Again, the valve stem and linkage should operate smoothly. Consult Figure-3 (mixing) or Figure-4 (diverting) for proper flow in the stem up position. After the valve linkage and the actuator are installed, check their operation.

# MAINTENANCE & FIELD REPAIR

Regular maintenance of the total system is recommended to assure sustained performance. See Figure-9 and Table-6 for maintenance kits and their part numbers.

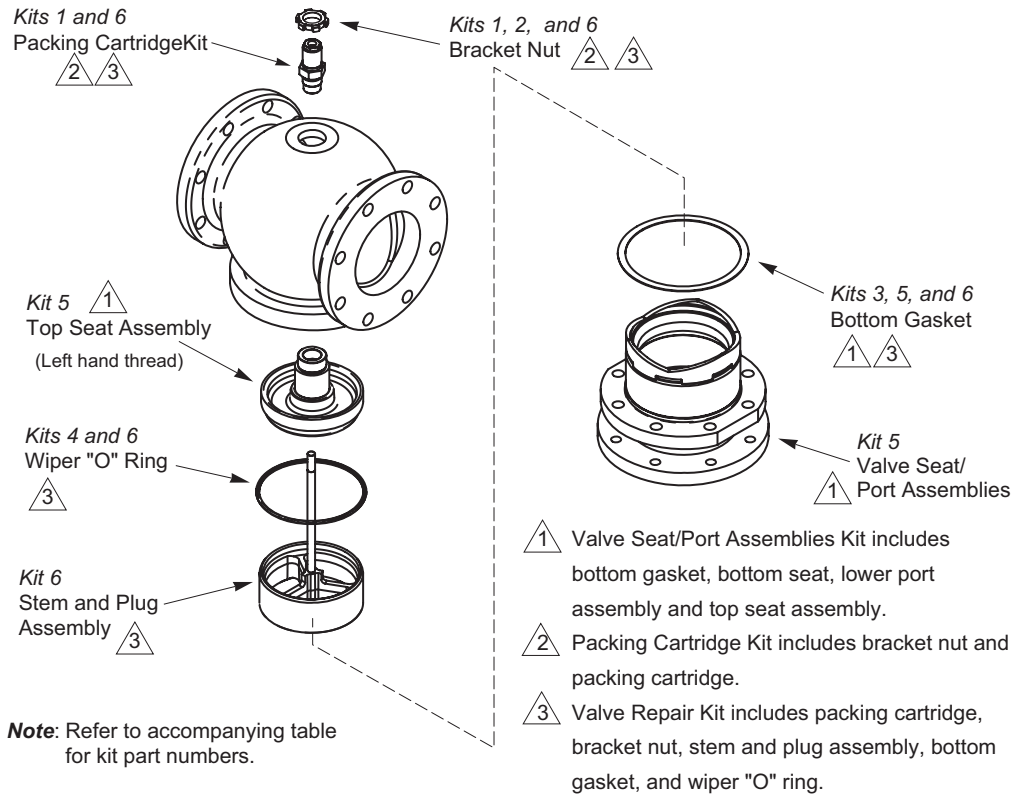

Figure-9 VB-8303 2-1/2" to 6" Maintenance Parts

Table-6 Maintenance Kits for VB-8303 Valves

Valve Body Part Number	Size	Kit 1	Kit 2	Kit 3	Kit 4	Kit 5	Kit 6
		Packing Cartridge	Bracket Nut	Bottom Gasket	Wiper "O" Ring	Valve Seat/Port Assemblies	Valve Repair Kit
VB-8303-0-5-12	2-1/2"	YBA-652-2	OYBB-225	BYRZ-13-12	NYBA-8303-104-0-12	YBA-830-101-0-12	RYB-830-12
VB-8303-0-5-13	3"			BYRZ-13-13	NYBA-8303-104-0-13	YBA-830-101-0-13	RYB-830-13
VB-8303-0-5-14	4"			BYRZ-13-14	NYBA-8303-104-0-14	YBA-830-101-0-14	RYB-830-14
VB-8303-0-5-15	5"			BYRZ-13-15	NYBA-8303-104-0-15	YBA-830-101-0-15	RYB-830-15
VB-8303-0-5-16	6"			BYRZ-13-16	NYBA-8303-104-0-16	YBA-830-101-0-16	RYB-830-16



**Caution:** Before loosening or removing packing cartridge, depressurize valve to zero psi gauge (0 psig). If the packing cartridge is loosened or removed while there is pressure in the valve, valve packing may blow out with the potential of bodily injury and/or water damage.



**Caution:** EPDM components are not compatible with petroleum-based compounds. Use of such compounds will damage packings and wiper "O" rings and necessitate replacement of packing cartridge and/or wiper "O" ring.

## Water System Maintenance

All heating and cooling systems are susceptible to valve and system problems caused by improper water treatment and system storage procedures. These guidelines are provided to help avoid valve and water system problems resulting from improperly treated water or storage procedures in cooling and hot water systems, and to obtain maximum life from TAC valves.

Durability of valve stems and packings is dependent on maintaining non-damaging water conditions. Inadequate water treatment or filtration, not in accordance with chemical supplier/ASHRAE handbook recommendations, can result in corrosion, scale, and abrasive particle formation. Scale and particulates can result in stem and packing scratches and can adversely affect packing life and other parts of the hydronic system.

To maintain non-damaging conditions, follow these guidelines:

- Clean the system prior to start up. Use a nitrite or molybdate-based treatment program.
- Use filtration equipment where needed.
- Properly store off-line systems and monitor water treatment results using corrosion test coupons.
- Follow the advice of a water treatment professional.
- Consult *EN-205 Water System Guidelines*, F-26080, for further details.

## DIMENSIONAL DATA

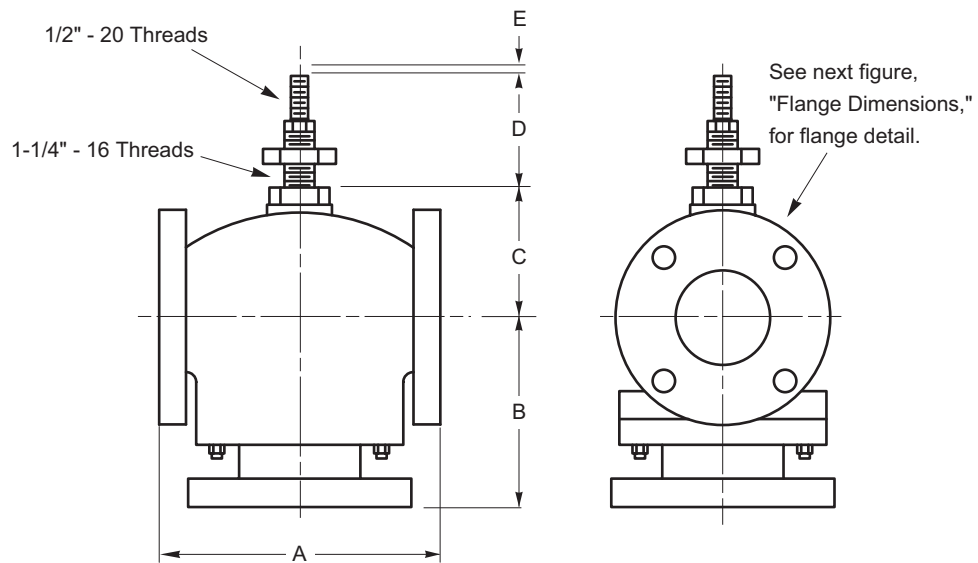

Figure-10 Typical of VB-8303-0-5-P,  
2-1/2" to 6" Valve Bodies

Table-7 Dimensions for VB-8303 Series Valves (Figure-10)

Part Number	Valve Size	Dimensions in Inches (mm)				
		A	B	C	D (Stem Down)	E (Nominal Stroke)
VB-8303-0-5-12	2-1/2"	8-9/16 (217)	5-7/16 (138)	4-3/16 (106)	3-1/4 (83)	1 (25)
VB-8303-0-5-13	3"	9-1/2 (241)	6-3/8 (162)	4-3/8 (111)		
VB-8303-0-5-14	4"	11-1/2 (292)	8-7/16 (214)	5-1/16 (129)		
VB-8303-0-5-15	5"	13 (330)	8-13/16 (224)	5-5/8 (143)		
VB-8303-0-5-16	6"	14 (356)	9-3/4 (248)	6-3/4 (171)		1-3/4 (45)

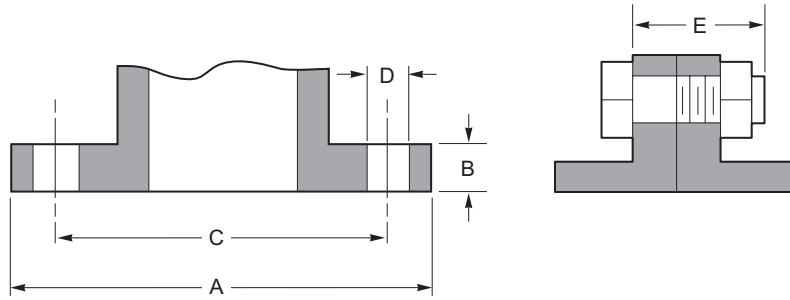

Figure-11 Flange Dimensions

Table-8 Flange Detail for American Standard 125 psi Cast Iron Pipe Flanges (Figure-11)

Nominal Pipe Size	Flanges		Drilling		Bolting		Length of Machine Bolts E
	Flange Diameter A	Flange Thickness B	Diameter of Bolt Circle C	Diameter of Bolt Holes D	Number of Bolts	Diameter of Bolts	
2-1/2"	7"	11/16"	5-1/2"	3/4"	4	5/8"	2-1/2"
3"	7-1/2"	3/4"	6"				
4"	9"	15/16"	7-1/2"	7/8"	8	3/4"	3"
5"	10"		8-1/2"				
6"	11"	1"	9-1/2"				



---

Copyright 2008, TAC  
All brand names, trademarks and registered  
trademarks are the property of their respective  
owners. Information contained within this  
document is subject to change without notice.

F-27197-4

**TAC**  
1354 Clifford Avenue  
P.O. Box 2940  
Loves Park, IL 61132-2940  
[www.tac.com](http://www.tac.com)

**t.a.c.** <sup>®</sup>  
by **Schneider Electric**