

# POWERS CONTROL®

## RC 195 Multiple Input Receiver-Controller

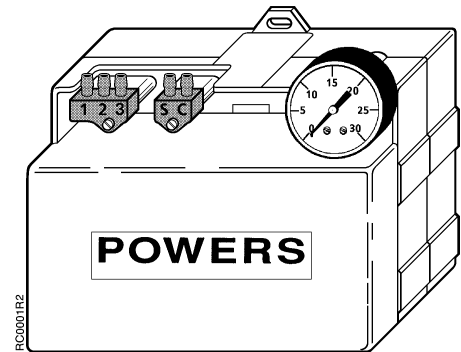

### Description

The RC 195 Multiple Input Receiver-Controller is a pneumatic instrument which receives one, two or three pneumatic inputs. It produces a pneumatic control signal based on the net pneumatic input and the mechanical settings, such as setpoint, percent proportional band and authority.

### Features

- Plug-in air connections make connecting, calibrating and servicing easy.
- Internal restrictors provided for transmitter inputs.
- Stick-on scales for setpoint dial in standard transmitter ranges in both English and metric units.
- Large, easy-to-read scales on all adjustments.
- Tamper-resistant cover.

### Application

The RC 195 Receiver-Controller is commonly used to control temperatures, humidity, and pressures of mechanical equipment in commercial buildings, such as offices, hospitals, universities and schools.

### Product Numbers

**Table 1.**

Product Number	Description
195-0003	Multiple Input Receiver-Controller with stick-on scales. See Table 2
195-066	Accessories* Restrictor Kit
195-067	Connector Kit
195-099	RC 195 Pressure Simulator for two transmitters
195-130	Scale dispensing sheet kit English and SI units DA and RA
153-054	Receiver-Controller Calibration Slide Rule
125-1661	Scale Conversion Card (Form, Single)
144-022	Scale Conversion Card (Form, pkg. 25)

\* Accessories must be ordered separately

<b>Specifications</b>  <b>Operating</b>	Action: Input #1 Input #2 Reset: Input #3	Direct Action (DA) Reverse Action (RA) Direct reset relative to Input #2 Reverse reset relative to Input #1
	Pneumatic inputs	3 to 15 psi (21 to 103 kPa)
	Control output	0 psi (0 kPa) to supply pressure
	Operating ambient temperature range	40 to 120°F (4 to 49°C)
	Supply pressure	
	Operating	22 psi (152 kPa)
	Maximum safe	30 psi (207 kPa)
	Percent proportional band adjustment range	2 to 20% for a 5 psi (34 kPa) control pressure change
	Percent authority adjustment range	20 to 200%
	Air consumption	60 scim (17 ml/s) not including transmitters
<b>Physical</b>	Mounting	Surface
	Air Connections	Barb fittings for 1/4-inch (6 mm) OD plastic tubing  Two plug-in connectors are provided: one for the three transmitter inputs and one for supply and control lines. 1/8-inch NPT connection provided for control pressure gauge
	Case material	Lexan, 20% glass filled
	Dimensions	See Figure 13
	Weight	3.1 lb (1.4 Kg)
	<b>Operation</b>  <b>Inputs</b>	<p>The control pressure depends upon the position of the main lever which is determined by the sum of the forces acting upon it. On the left side of the pivot, three forces act against the lever: the bias spring, the #1 input pressure, and the #3 input pressure acting through the authority slide.</p> <p>On the right side of the pivot, three forces act up against the lever; the control pressure acting through the percent proportional band slide, the # 2 input pressure, and the setpoint spring. See Figure 1.</p> <p>When the net forces on each side of the pivot are equal, the lever is stationary and the control pressure is constant. A change in any of the forces moves the main lever to a new equilibrium position and provides a new control pressure. The inputs on the left side of the pivot (#1 and #3) are direct acting and the input on the right side of the pivot (#2) is reverse acting.</p> <p>An internal 40 scim (11 ml/s) restrictor is furnished for each input. Each transmitter restrictor must be switched "in" when an external restrictor is not being used. When any input is not being used, its restrictor should be in the "out" position and the input connection should be open to the atmosphere. Restrictor "A" provides nozzle pressure and restrictor "B" minimizes hysteresis in the pilot relay. See Figure 1.</p>

**Operation,  
 Continued**

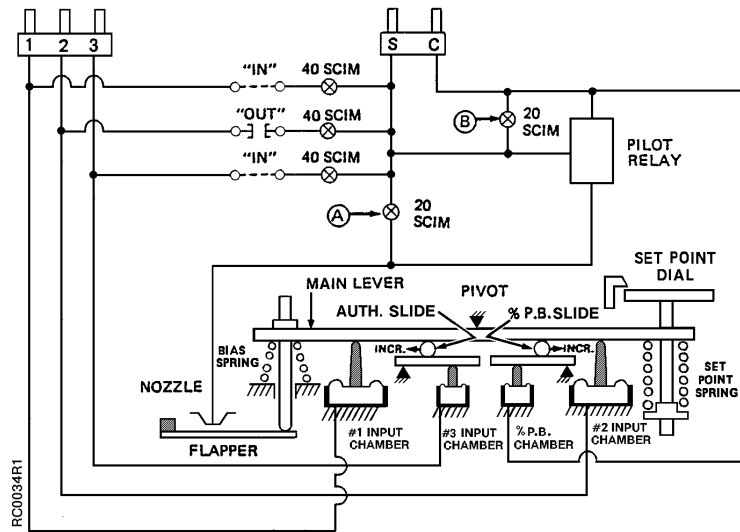

**Figure 1. Multiple Input Receiver-Controller Schematic.**

**Percent Proportional  
 Band**

The pilot relay amplifies the nozzle pressure to provide the control pressure output. Control pressure goes to the controlled device(s) as well as the percent proportional band chamber to provide proportional feedback. For example, if the main lever is moved up on the left side of the pivot, the flapper will move toward the nozzle to increase control pressure. The increased pressure in the percent proportional band chamber will move the main lever up on the right side of the pivot, moving the flapper away from the nozzle until an equilibrium and a new control pressure are reached. The amount of feedback is adjusted by moving the percent proportional band slide.

**Authority**

Authority is defined as the ratio of the change of the #1 or #2 input pressure to the change of the #3 input pressure for the same control pressure change. The authority slide provides a means of adjusting this ratio.

**Authority Application**

The RC 195 Receiver-Controller can be used as a one input (DA or RA) a two input (DA or RA with reset), or a three input instrument (DA or RA with reset and control point adjust).

On reset applications, inputs 1 and 3 provide direct action with reverse reset (Figure 2), and inputs 2 and 3 provide reverse action with direct reset (Figure 3). When other combinations of action and reset are required (reverse action with reverse reset or direct action with direct reset) use the combination of inputs that provide the proper reset action and add a reversing relay in the control line of the RC 195 to change the action (Figure 4).

**Authority Application,  
 Continued**

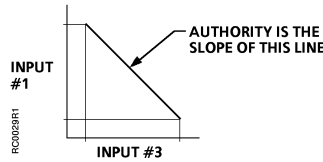

**Figure 2. Authority for Reverse Reset.**

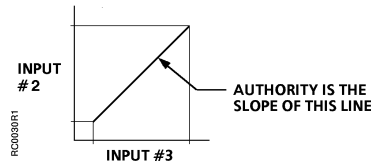

**Figure 3. Authority for Direct Reset.**

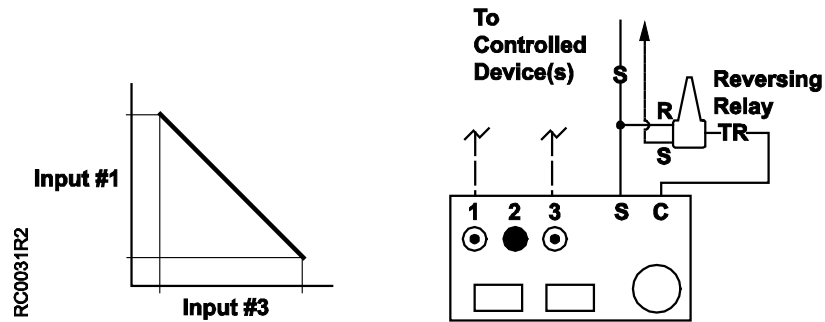
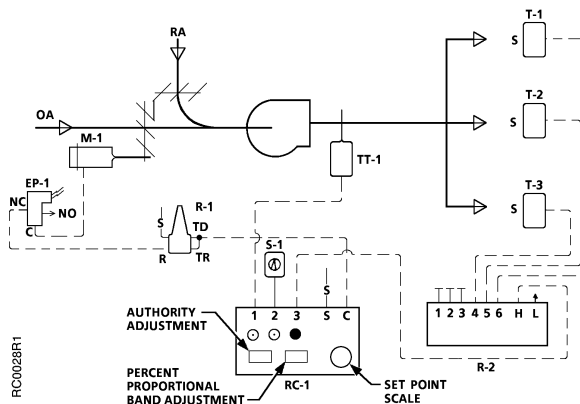

**Figure 4. Receiver-Controller Using an RA Relay to Provide Reset Action with Reverse Reset.**

**Description of  
 Application**

**Mixed Air Control - Reset From Zone – See Figure 5**

Whenever the fan is running, EP Valve (EP-1) is energized to allow control of damper motor (M-1). Multipurpose Relay (R-1) provides minimum percentage outdoor air. Temperature Transmitter (TT-1) senses the mixed air temperature and sends a signal to Receiver-Controller (RC-1). RC-1 modulates M-1 to maintain desired mixed air temperature. Mixed air temperature setpoint is reset by the warmest zone thermostat (T-1, T-2, T-3) through Signal Selector Relay (R-2). Positioning Switch (S-1) allows manual reset of the mixed air setpoint at a remote location.



**Figure 5. Typical Mixed Air Control Application.**

**Installation**

**General**

- The receiver-controller may be mounted in any position on any vertical surface using two #8 or #10 screws. The integral mounting tabs are located on the top and bottom of the case.

**NOTE:** Small vibrations such as those from an air handling unit will not affect the operation of the instrument.

- Remove the cover by pulling it to the right; lifting, then pulling to the left and lifting. Remove the cover for access to the percent proportional band adjustment, the authority slide, the setpoint dial, and setpoint adjustment screw.
- The setpoint dial comes with a 3-15 psi (21 to 103 kPa) scale. Place one of the stick-on scales (Table 2) on the dial to match the primary transmitter range. Each scale is marked DA or RA to match the required action of the receiver-controller.
- Check all the air connections, particularly those to the transmitters, to eliminate any leaks. Even small leaks in the pneumatic lines to the transmitters will introduce large errors.
- Check the supply pressure. The supply pressure must be a constant 22 psi (152 kPa). If it is different or if a dual air supply is used, errors will be introduced into the transmitted signals.

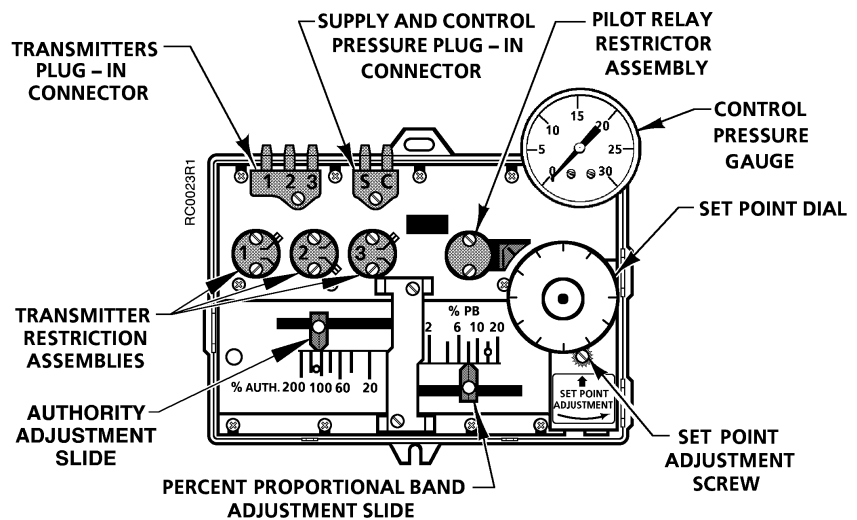

**Figure 6. Multiple Input Receiver-Controller Connector, Restrictor, and Adjustment Locations.**

## Installation

**Table 2. Scale Ranges.**

English	Scale Identification	Metric
-40°F to 120°F	A	-40°C to 50°C
50°F to 100°F	B	10°C to 38°C
80°F to 240°F	C	26°C to 117°C
20% to 80% rh	D	20% to 80% rh
0°F to 100°F	E	-18°C to 38°C
35°F to 135°F	F	1°C to 58°C
0 IWG to 3 IWG	G	0 Pa to 750 Pa
0 IWG to 15 IWG	H	0 kPa to 3.75 kPa
0 IWG to 0.5 IWG	J	0 Pa to 125 Pa
Blank 10 divisions Blank 16 divisions	K (DA) K (RA)	Blank 9 divisions Blank 11 divisions
-0.05 IWG to 0.20 IWG	L	-12.5 Pa to 50 Pa
-0.5 IWG to 0.5 IWG	M	-125 Pa to 125 Pa
0 IWG to 10 IWG	N	0 kPa to 2.5 kPa
Blank 20 divisions	P	Blank 15 divisions
0 psi to 50 psi	R	0 kPa to 345 kPa
50°F to 150°F	S	10°C to 66°C
40°F to 240°F	T	4°C to 116°C
-40°F to 160°F	V	-40°C to 71°C

## Restrictors

Restrictors are factory installed in all inputs of the receiver-controller. Restrictors are in the "out" position as shipped from the factory. When an internal restrictor is required, the restrictor must be moved to the "in" position. Use the following procedures when dialing a new restrictor position:

- If the transmitter input line is connected to "1", use restrictor "1".
  - If the transmitter input line is connected to "2", use restrictor "2".
1. Loosen both restrictor screws two full turns.
  2. Move the restrictor tab back and forth between the full travel limits a minimum of two times or until there is no sensation of drag against the lever. This will allow the gasket to return to its proper position.
  3. Tighten both screws with the restrictor lever fully in position against its stop. Do not over tighten the screws. Screws should be tight enough to provide a good seal without warping the restrictor assembly.

**NOTE:** When an Input is not used, the restrictor should be in the "out" position and the input connection should be open to atmosphere.

**Installation,  
 Continued**

Figure 7 gives the maximum recommended distances for using the internal restrictor, external restrictor, and remote gauges. Note that 300 feet (91.5 m) is the maximum distance between air supply and the transmitter. If the distance is more than 300 feet (91.5 m) between transmitter and receiver-controller, a remote air supply and external restrictor must be used. If the maximum distances are exceeded, there will be excessive pressure drops and time delays which will produce faulty indication and unsatisfactory operation.

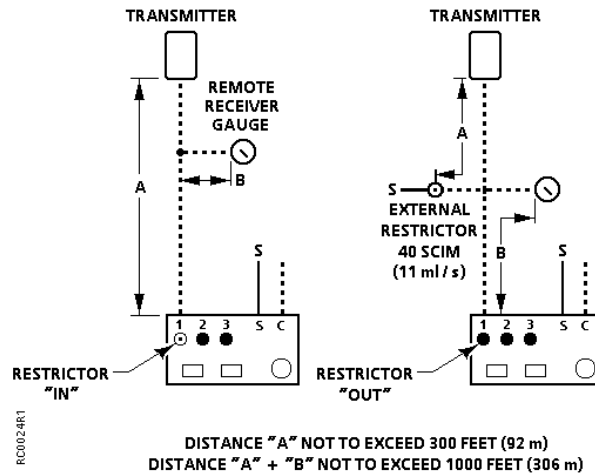

**Figure 7. Maximum Distances for External Restrictors and Remote Gauges.**

Generally, 1/4-inch (6.4 mm) OD plastic tubing should be used for all the connections to the plug-in air connectors. Larger size tubing will reduce the pressure drops, but will increase time delays.

Conversely, smaller tubing will reduce time delays but will increase pressure drops.

**Calibration**

Before making adjustments, several calculations are necessary. Steps 1, 2, 3 and 4 can be completed before installation and are normally made by the field engineer with the values noted on the control drawing. See Figure 8.

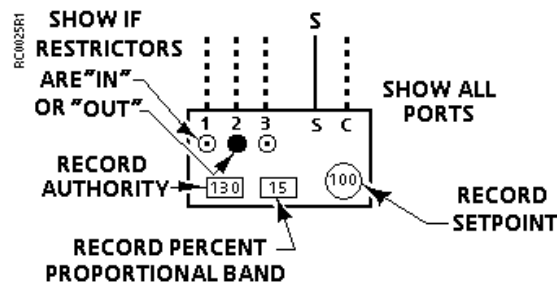

**Figure 8. Control Drawing.**

**Calibration,  
 Continued**

**Step 1** Determine Percent Proportional Band setting using Formula A or Table 3.

**Formula A**

$$\% \text{ P.B.} = \frac{\text{Desired Throttling Range } (^{\circ}\text{F or } ^{\circ}\text{C})}{\text{Controlling Transmitter Span } (^{\circ}\text{F or } ^{\circ}\text{C})} \times \frac{*5 \text{ psi or } 34.5 \text{ kPa}}{\text{Spring Range Final Controlled Device (psi or kPa)}} \times 100$$

\* This is the control pressure change for which the percent proportional band scale is designed.

**Example 1:**

5 psi (34.5 kPa) spring range  
 Desired throttling range 10°F (5.6 °C)  
 Transmitter span 100°F (56°C)  
 Using Formula A:

$$\% \text{ P.B.} = \frac{10^{\circ}\text{F}}{100^{\circ}\text{F}} \times \frac{5 \text{ psi}}{5 \text{ psi}} \times 100$$

Percent proportional board = 10%

For metric:

$$\% \text{ P.B.} = \frac{5.6^{\circ}\text{C}}{56^{\circ}\text{C}} \times \frac{34.5 \text{ kPa}}{34.5 \text{ kPa}} \times 100$$

Percent proportional board = 10%

**Table 3. Percent Proportional Band Settings.**

Transmitter Span °F (°C)	Percent Proportional Band Setting					
	5 psi (34 kPa) Spring			10 psi (69 kPa) Spring		
	Desired Throttling Range °F (°C)			Desired Throttling Range °F (°C)		
	4 (2)	8 (4)	12 (7)	4 (2)	8 (4)	12 (7)
50 (28)	8%	16%	-	4%	8%	12%
100 (56)	4%	8%	12%	2%	4%	6%
160 (89)	2.5%	5%	7%	-	2.5%	3.8%



**Calibration,  
 Continued**

**Step 2** Determine Percent Authority Setting using Formula B (Figure 9) or graphically.

Using Formula B:  
 % Authority =

$$\frac{\text{Change of input 1 or 2} + \text{TR}}{\text{Span of input 1 or 2}} \times \frac{\text{Span of input 3}}{\text{Change of input 3}} \times 100$$

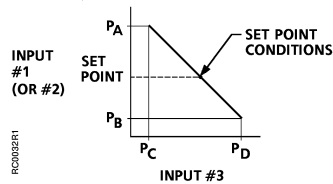

**Figure 9. Graph of Percent Authority Formula.**

Where:

Change of input 1 or 2 = PA - PB

Change of input 3 = PD - PC

T.R. = Throttling range

**Example 2:**

Assume a hot deck reset schedule as shown in Figure 10 and a 10°F (5.6°C) throttling range.

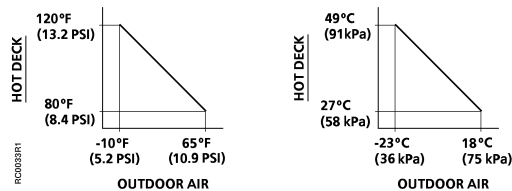

**Figure 10. Sample Percent Authority.**

°F:

$$\% \text{ authority} = \frac{(120-80 + 10)}{100} \times \frac{160}{65-(-10)} \times 100$$

Percent authority = 107%

°C:

$$\% \text{ authority} = \frac{(49-27) + 5.6}{56} \times \frac{89}{18-(-23)} \times 100$$

Percent authority = 107%

---

## Calibration, Continued

### Step 3 Determine Setpoint Conditions.

For most applications it is necessary to select one point called "Setpoint Conditions" to establish the value of all variables.

- For a single input receiver-controller, the setpoint condition equals the desired control point. This is expressed in percent relative humidity, degrees Fahrenheit, inches W.G., or metric units.
- For two and three input receiver-controllers the setpoint conditions equal the midpoint of the usable portion of the schedule. See Figure 9. This is expressed in percent RH, degrees Fahrenheit, inches W.G., or metric units.

### Step 4 Record data from Steps 1, 2, and 3 on Control Drawing.

Figures 5 and Figure 8 show how the values of percent proportional band, the percent authority, and setpoint should be recorded.

---

## Calibration Adjustments

**NOTE:** Whenever the proportional band is changed, the setpoint dial must be recalibrated.

### Single Input

1. Set proportional band pointer to value shown on the control drawing.
2. Apply setpoint pressure to selected input (#1/DA or #2/RA) and with a screwdriver turn the setpoint adjustment screw until control pressure reaches 8 psi (55 kPa) or midpoint pressure of the spring range of actuator.
3. Calibrate setpoint dial by pulling it up, turning it to agree with the transmitter input, and then releasing it.
4. Turn the setpoint adjustment screw until dial agrees with control drawing.

---

### Two or Three Inputs

1. Attach the RC 195 Simulator by means of the plug-in connector. See *Technical Instructions RC 195-3 (155-103P25)* for details.
  2. Proportional band. Move the pointer to the desired setting on the proportional band scale of the receiver-controller.
  3. Authority. When input three is used, move the pointer to the desired setting on the authority scale of the receiver-controller.
  4. Simulate setpoint conditions. Adjust the knobs on the simulator so that all the pneumatic inputs are at their setpoint condition.
  5. Setpoint. Turn the setpoint adjustment screw of the receiver-controller to obtain the desired control pressure. Pull the setpoint dial up, turn it to agree with the control schematic and then release it.
  6. Check operation. Pneumatic inputs corresponding to both ends of the reset schedule can be simulated to ensure that the receiver controller is in calibration throughout its entire range. Minor variations of 2 to 3 psi (14 to 21 kPa) in the control pressure are normal.
-

**Troubleshooting**

Before troubleshooting the operation of the RC 195 Multiple Input Receiver-Controller, verify the following:

1. Supply pressure at the unit is 22 psi (152 kPa).
2. Transmitter input being used is between 3 and 15 psi (21 to 103 kPa).
3. Only one restrictor supplies the transmitter.
4. Transmitter calibration is correct.

**Table 4. Troubleshooting Guide.**

Complaint	Check		Probable Cause	Corrective Action
Control pressure stays at approximately zero	Rotate setpoint adjustment screw counterclockwise	Pressure increases	Transmitter sensing medium which is above (RA) or below (DA) the proportional band	None
			Receiver controller out of calibration	Recalibrate
		Pressure remains unchanged	Plugged pilot relay restrictors	Replace Pilot Relay Restrictors
			Receiver-Controller is defective	Replace Receiver Controller
Control pressure stays at approximately supply pressure	Rotate setpoint adjustment screw clockwise	Pressure decreases	Transmitter sensing medium which is above (DA) or below (RA) the proportional band	None
			Receiver-Controller out of calibration	Recalibrate
		Pressure remains unchanged	Receiver-Controller is defective	Replace Receiver-Controller

## Troubleshooting, Continued

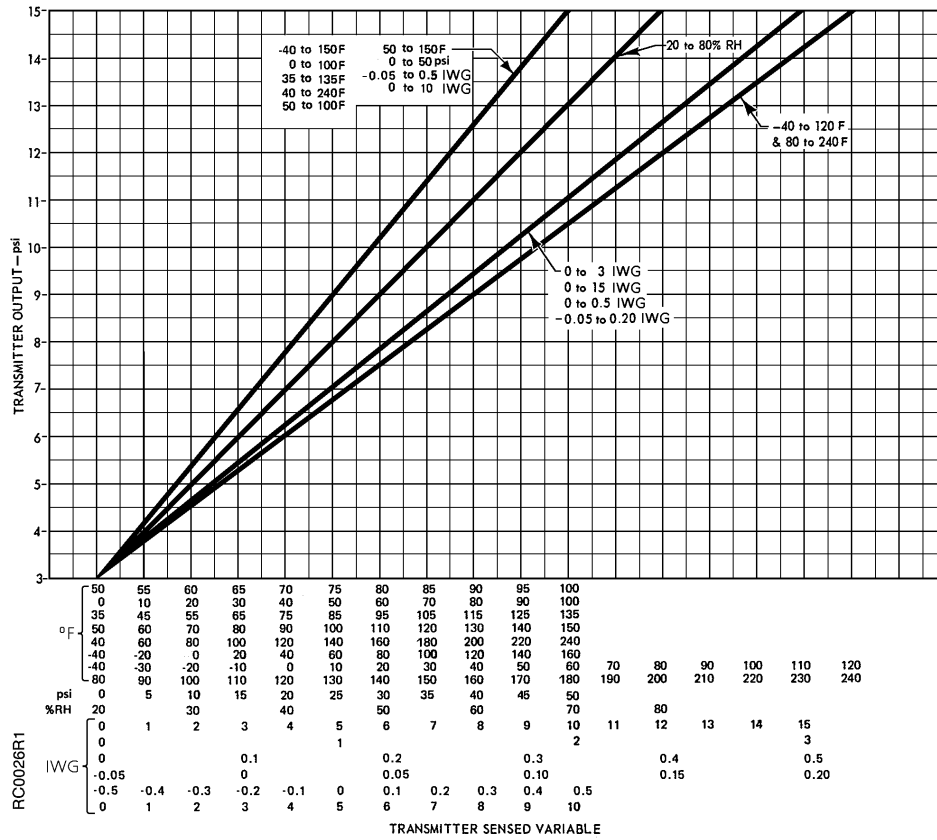

Figure 11. Output Pressure/Transmitter Range Relationship In English Units.

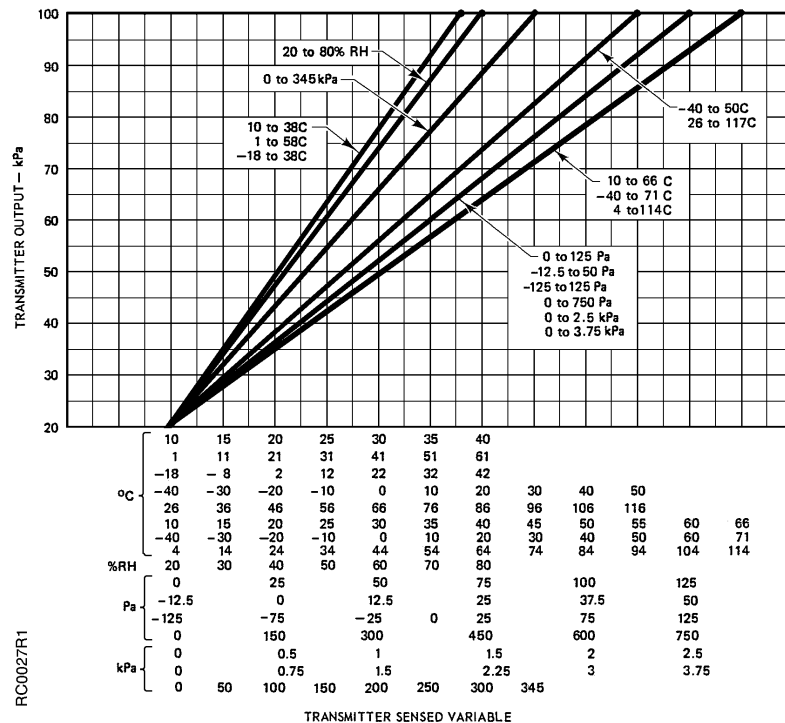
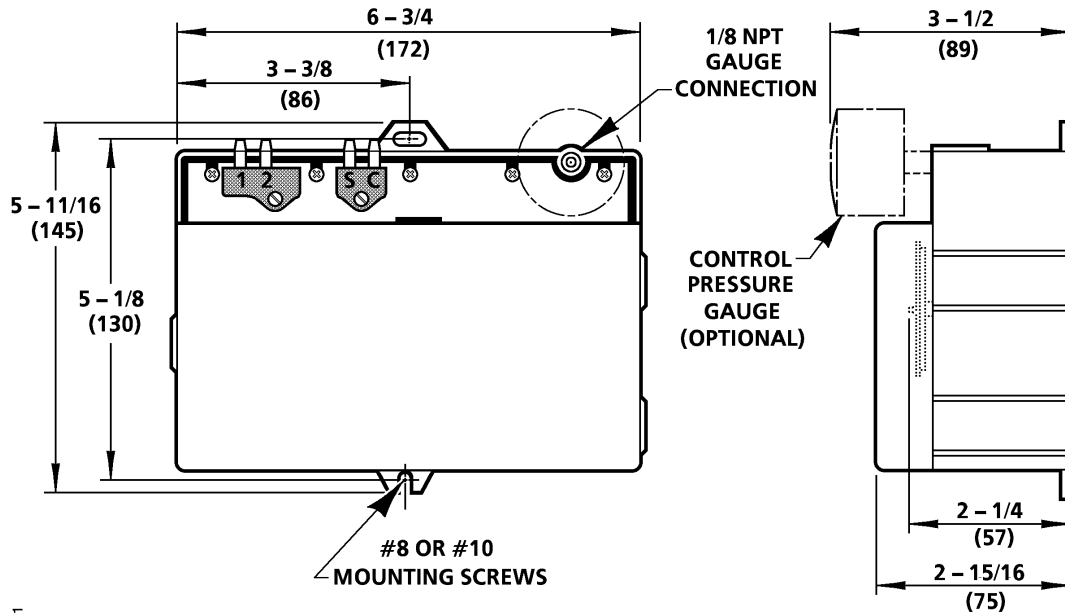

Figure 12. Output Pressure/Transmitter Range Relationship In English Units.

**Dimensions**



RC0009F1

**NOTE: DIMENSIONS IN INCHES  
 MILLIMETERS IN PARENTHESES**

**Figure 13. Dimensions.**

Information in this publication is based on current specifications. The company reserves the right to make changes in specifications and models as design improvements are introduced. POWERS CONTROL is a registered trademark of Siemens Industry, Inc. Other product or company names mentioned herein may be the trademarks of their respective owners. © 2015 Siemens Industry, Inc.