

# POWERS™ CONTROLS

## TH 357 LIMITEM® Remote Bulb Thermostat

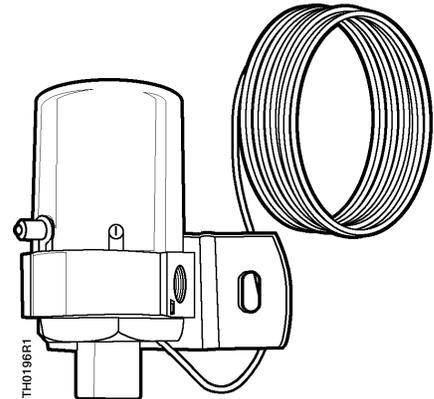

### Description

The TH 357 LIMITEM is a gradual-direct acting thermostat for air temperature control. This pneumatically operated instrument senses a temperature and passes on a pneumatic signal whose pressure is proportional to the temperature sensed. The sensing element is liquid-filled, and is available in remote and averaging bulb styles.

### Features

- Two-valve design eliminates wasting air.
- Rapid response to temperature change.
- Adjustable sensitivity.

### Application

The TH 357 LIMITEM can be used to control air temperatures in a variety of air handling units. Typical applications are as primary controller for an air handling unit or a low limit control.

**Table 1. Product Numbers.**

Specifications						
Sensing Element	Operating Range	Bulb	Capillary	Max. Ambient Temperature of Bulb	Sensitivity Adjustable	Product Number
Liquid Filled Remote Bulb	20 to 100°F (-6.7 to 37.8°C)	3/8 in. x 4.0 in. (0.95 x 10.2 cm)	8.0 ft (2.4 m)	201°F (94°C)	1/3 to 3-1/2 psi/°F (4 to 43 kPa per °C)	357-0003
	120 to 230°F (48.9 to 110°C)	3/8 in. x 4.0 in. (0.95 x 10.2 cm)	40.0 ft (12.2 m)	261°F (127°C)	1/3 to 2-1/4 psi/°F (4 to 28 kPa per °C)	357-0005
Liquid Filled Averaging Bulb	35 to 145°F (1.7 to 62.8°C)	3/32 in. x 15 ft (0.24 x 457 cm)	40.0 ft (12.2 m)	210°F (99°C)	1/3 to 2-1/4 psi/°F (4 to 28 kPa per °C)	357-0004
	35 to 145°F (1.7 to 62.8°C)	3/32 in. x 8 ft (0.24 x 244 cm)	0.5 ft (15 cm)	211°F (99.4°C)	1/3 to 3-1/2 psi/°F (4 to 43 kPa per °C)	357-0001

**Specifications**

Operating range	See Table 1
Control Action	Direct
Temperature response	0.5°F (0.3°C)
Maximum supply air pressure	30 psi (207 kPa)
Maximum ambient temperature of case	180°F (82°C)
Air connection	1/8-inch NPT
Shipping weight	2 lbs (0.9 kg)
Dimensions	See Figure 2

**Accessories**

Mounting flange	808-412
Remote bulb holder	808-517
Copper well	38Y210 (Grainger)
Coil clip	356-115
Capillary clip (box of 100)	7421700060

**Operation**

As temperature increases, the liquid within the thermal system expands and moves the supply valve body away from the ball valve, causing a gradual increase of air pressure in the return line. (The ball is closed against the exhaust valve while the supply valve is open, preventing constant air waste.) Increased pressure in the return air chamber causes the exhaust valve to compress the sensitivity spring. When the temperature decreases, the ball is moved away from the exhaust seat simultaneously closing against the supply valve. Both valves are closed when the control is satisfied.

As the temperature decreases, the liquid within the thermal system contracts. Return air pressure moves the supply and the ball valve away from the exhaust valve, gradually reducing the return line air through the exhaust port. Lower pressure in the return air chamber reduces the force against the exhaust valve. The sensitivity spring expands and the exhaust valve moves gradually toward the ball valve reducing the return air waste.

The throttling range is changed by moving the sensitivity spring to a new position. Sensitivity is most gradual 1/3psi/1°C or (4 kPa/°C) when the open end of the spring is under the adjusting screw. Factory setting is at the center of the sensitivity spring. When changing the sensitivity adjustment, care should be exercised to not cock or distort the exhaust valve diaphragm. Any change to the spring's position affects calibration and requires resetting the dial.

The return line vent, factory set for 1/2 CIM (0.27 to 0.55cm<sup>3</sup>/s), prevents the air from being trapped in the return line when the LIMITEM<sup>®</sup> is piloted from a room thermostat.

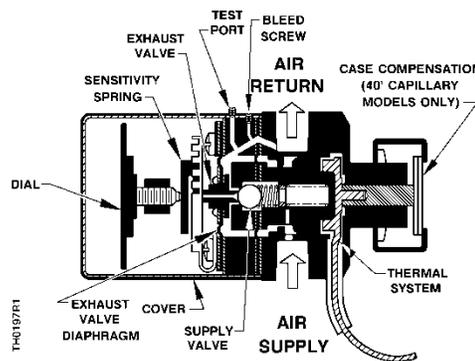
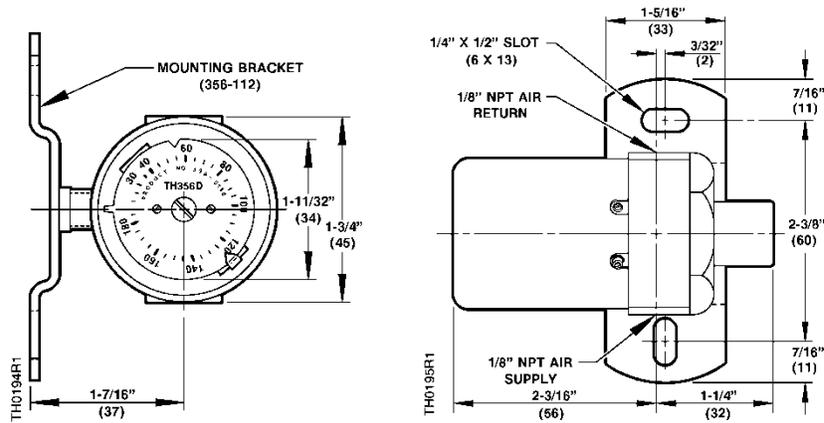

**Figure 1. Operation.**

**Installation**

**Mounting the TH 357 LIMITEM body.**  
 (See Figure 2.)

- A 1/8-inch NPT opening in the LIMITEM body is provided for mounting.
- The mounting bracket (furnished with thermostat) may be attached to any flat surface and the thermostat body threaded onto the protruding pipe nipple.
- When metal tubing is used for the supply and return air lines, this tubing may also serve to support the body of the thermostat.



**Figure 2. Mounting and Dimensions of the TH 357 Remote and Averaging Bulb Limitem.**

**Mounting the TH 357 LIMITEM Bulb**

- When mounting the bulb through a metal surface, protect the bulb by using a mounting flange with a rubber grommet.

**Remote bulb**

- Use a remote bulb holder No. 808-517 to support the remote bulb. See Figure 3. The holder may be shortened to fit small ducts.
- When the bulb is mounted in a unit ventilator, use coil clip No. 356-115 to support the bulb in the air stream close to the coil. See Figure 4 and Figure 5.
- When installing the remote bulb in a pipeline, use copper well Grainger number 38Y210.

**Installation, continued**

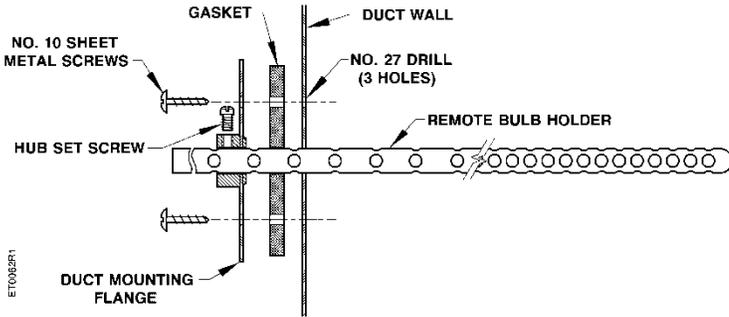

**Figure 3. Remote Bulb Holder Kit 808-517.**

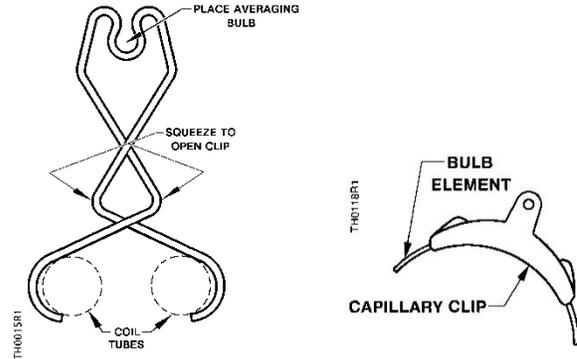

**Figure 4. Clips, 356-115 and 7421700060.**

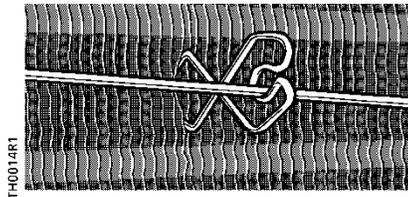

**Figure 5. Clip Mounted on Coil.**

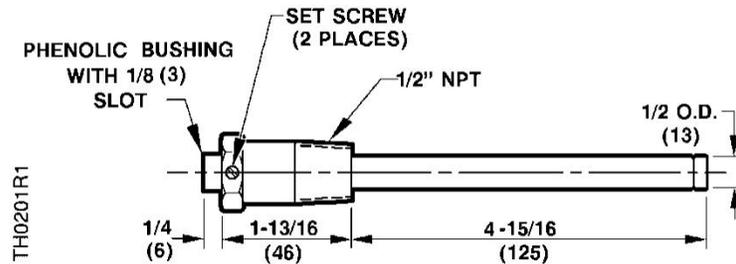
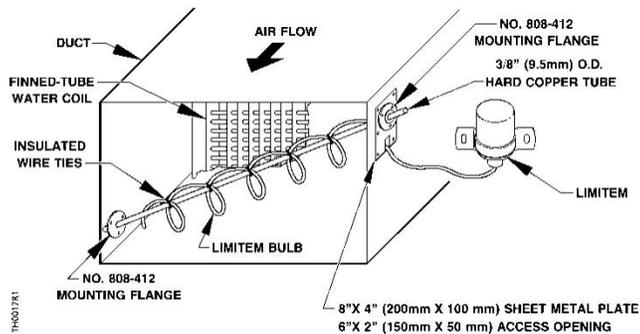
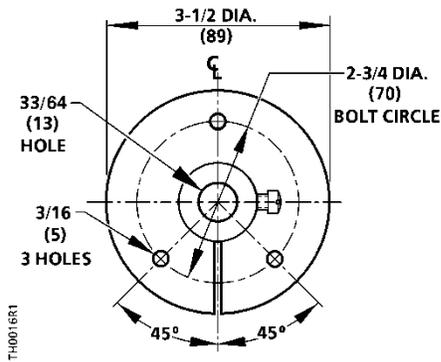

**Figure 6. Copper Well Grainger number 38Y210.**

**Averaging bulb mounting**

Averaging bulbs require some means of support for the bulb and capillary.

- Use a coil clip, Part No. 356-115 (Figure 4 and Figure 5) or a capillary clip, Part No. 7421700060 (Figure 4), to support the bulb if there is easy access to the coil.
- For duct mounting where access to the coil is limited, see Figure 7. Use flange No. 808-412 and a length of 3/8 inch (9.5 mm) OD hard copper tube to expose the bulb to the air leaving the coil within the duct.



**Figure 7. Installation of TH 357 Averaging Bulb in a Duct.**

**Calibration**

**To change setpoint**

1. Remove the cover.
2. With a screwdriver, turn the dial adjustment screw to change to the desired setpoint. See Figure 8.

**To calibrate**

1. Using a test thermometer, accurately measure the temperature at the bulb.
  2. Set the dial to the bulb temperature by turning the dial adjustment screw with a screwdriver.
- NOTE:** You must use a screwdriver. Do not attempt to change the dial by rotating it with your hand.
3. If a permanent return air gauge is not installed, use the pressure test port. See Figure 8 for its location.
  4. Loosen the test port screw about 1/2 turn, and slip a 3/16-inch ID rubber hose connected to the test gauge over the pressure test port. See Figure 9.
  5. If the return pressure does not read 7 to 8 psi (48-55 kPa) turn the dial adjustment screw with a screwdriver until pressure is 7 to 8 psi (48-55 kPa).
  6. Loosen the dial screws and turn dial until the temperatures at the bulb and dial are identical. Tighten the screws.

The thermostat is now calibrated and setpoint may be changed as desired.

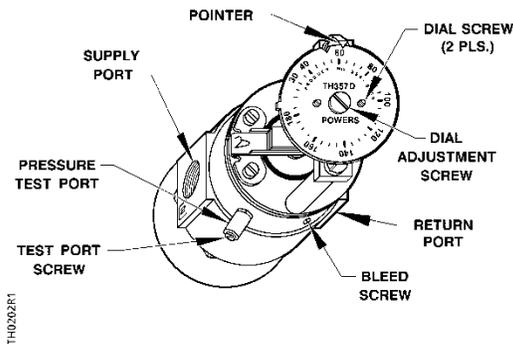

**Figure 8. LIMITEM® Cover Removed.**

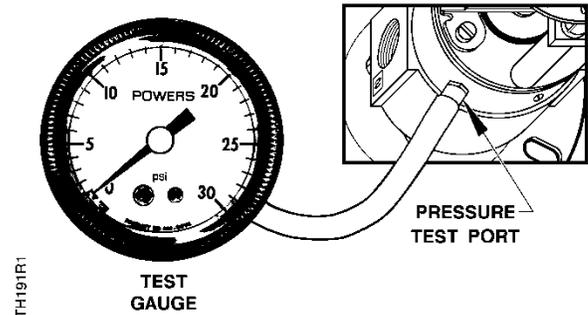

**Figure 9. Using the Pressure Test Port.**

**Sensitivity Adjustment**

The sensitivity adjustment is factory set with the sensitivity spring tab in position 6 of the spring retainer. This is approximately mid span of the sensitivity. Move the sensitivity spring to a lower slot number for more gradual setting. Move the sensitivity spring to a higher slot number for more positive setting. See Table 2.

To change the sensitivity:

1. Loosen the dial screws. See Figure 8.
2. Loosen the dial adjustment screw.
3. Lightly press, but do not bend, the spring retainer. See Figure 10.
4. Move the sensitivity spring to the new position. See Figure 10. Table 2 gives the sensitivity spring tab location and the corresponding sensitivity value.

**NOTE:** The tab may be installed in either side of the spring retainer.

5. Ensure that the dial adjustment screw point touches the sensitivity spring.
6. Recalibrate the unit.
7. If you need to adjust again, allow five minutes for the control cycle to settle before repeating the steps above.

Table 2.		
Slot No.	Sensitivity psi/°F	
	Remote Bulb	Rmt Bulb 40' Cap
1	0.33	0.33
2	0.60	0.54
3	1.03	0.76
4	1.39	0.97
5	1.74	1.18
6	2.09	1.40
7	2.44	1.61
8	2.79	1.82
9	3.15	2.03
10	3.5	2.29
11	3.5	2.29

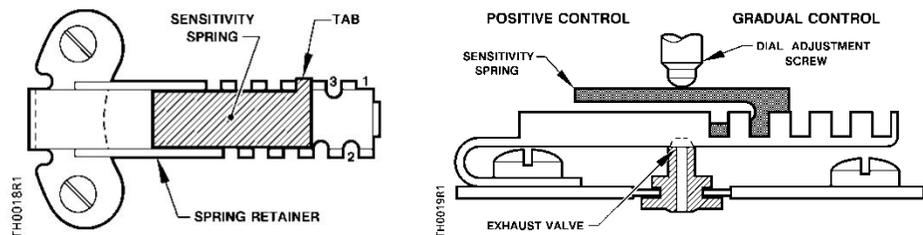

**Figure 10. Sensitivity Spring Setting.**

**Troubleshooting**

If the LIMITEM<sup>®</sup> fails to operate properly, use Table 3 as a troubleshooting guide. Ensure that the thermostat receives 18 to 30 psi (124 to 207 kPa) of clean, dry, oil-free supply air. Also, use a test gauge with a length of 3/16-inch ID rubber hose to measure the return pressure at the test port if permanent gauges are not available.

**Service**

The LIMITEM cannot be serviced. Replace the thermostat if inoperative after checking the troubleshooting table.

**Table 3. Troubleshooting Chart.**

Complaint	Check		Probable Cause	Corrective Action
	Supply air Pressure		Low Pressure	As Required
Return Line pressure stays at approx. zero	Press the exhaust valve	If return is still zero psi	Defective valve assembly	Replace thermostat.
		If return pressure increases	Out of calibration or damaged sensing element	1. Recalibrate. 2. With 6 to 9 psi return pressure, vary temperature at the bulb. If no change in return pressure, replace thermostat.
Return Line pressure stays at approx. supply pressure	Using a screwdriver, rotate setpoint dial counterclockwise to the limit stop	If return pressure remains high	Defective valve assembly	Replace thermostat.
		If return pressure drops to zero	Out of calibration	Recalibrate.
Excessive air leakage from exhaust valve	Supply and return line connection		Connections are interchanged	Reverse the supply and return connections.
Temperature cycles rapidly	Sensitivity setting		Improper setting	Move the sensitivity spring to a more gradual (lower number) slot setting. See <i>Sensitivity Adjustment</i> .
Temperature wanders from control point	Sensitivity setting		Improper setting	Move the sensitivity spring to a more positive (higher number) slot setting. See <i>Sensitivity Adjustment</i> .

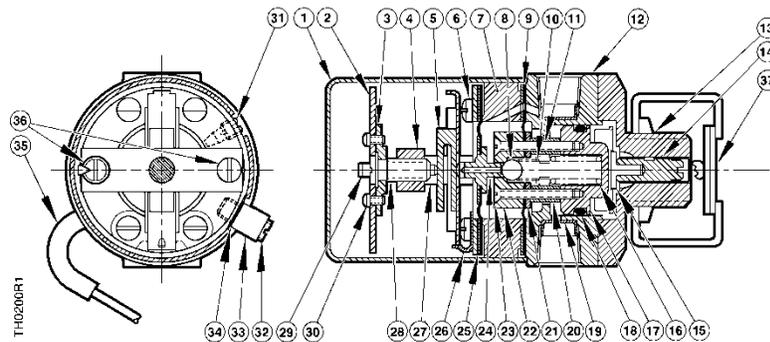

Figure 11. Construction of the Remote Bulb LIMITEM®.

Table 4. Parts List.

Item	Part	Qty	Part Number
1	Cover	1	—
2	Dial	1	—
3	Lock Plate	1	—
4	Bridge	1	—
5	Sensitivity Spring	1	—
6	No. 6-32 x 1-3/8" Lg.Fil. head screw	4	—
7	Housing Ring	1	—
8	Ball	1	—
9	Lower Diaphragm	1	—
10	Spring	1	—
11	No. 3-48 x 3/4" Lg.Fil. head screw	2	—
12	Body	1	—
13	Flange	1	—
14	Adjustment Screw	1	—
15	Sensing Element	1	—
16	Bias Spring	1	—
17	Element Retainer	1	—
18	O-Ring	1	—
19	Screen Filter	2	—
20	Lower Spacer	2	—

Table 4. Parts List, Continued.

Item	Part	Qty	Part Number
21	Retaining Ring	1	—
22	Supply Valve	1	—
23	Sealing Gasket	2	—
24	Exhaust Valve and Diaphragm Assembly	1	—
25	Diaphragm Ring	1	—
26	Retaining Spring	—	—
27	Upper Spacer	2	—
28	Dial Adjustment Screw	1	—
29	Pointer	1	—
30	Dial Screws	2	—
31	Bleed Screw	1	—
32	Test Plug	1	—
33	Test Valve Body	1	—
34	Valve Gasket	1	—
35	Sleeve	1	—
36	No. 6-32 x 1-7/8" Lg.Fil. hd. machine screw	2	—
37	Bimetal (40 ft capillary models)	2	—

Information in this publication is based on current specifications. The company reserves the right to make changes in specifications and models as design improvements are introduced. POWERS is a trademark, and LIMITEM is a registered trademark of Siemens, Industry, Inc. Other product or company names mentioned herein may be the trademarks of their respective owners. © 2017 Siemens Industry, Inc.