

GWNP

Modular Gas Sensor Platform Accepts AG Series Gas Sensors



GWNP

AGPE Enclosure
(sold separately)

GWNP Series protocol communications platform offers a convenient means for sensing gases in the environment. The GWNP is mounted to any single-gang electrical box and wired to the building controller. Then, a single AGxx gas sensor (sold separately) is installed in the GWNP. With this design, there is no need for a costly new installation when a sensor reaches the end of its life. The GWNP platform remains installed, and the installer simply opens the GWNP housing to replace the modular sensor inside, reducing labor costs and downtime.

AG Series sensors can be swapped in the GWNP platform at any time with minimal effort. The GWNP platform converts the signal from the AG sensor into protocol communications compatible with building control systems.

The available AGPE metal enclosure (sold separately) provides a modular solution for applications that require a rugged enclosure along with an integral audible horn and 10 A relay for direct fan control.

SPECIFICATIONS

Input Power	15 to 30 Vdc/24 Vac ±20%, Class 2, 50/60Hz, max. 60 mA
Relay Ratings	1A/30 Vac/dc, normally open
Operating Temperature Range	-20 to 50 °C (-4 to 122 °F)
Operating Humidity Range	0 to 90% RH non-condensing
Terminal Block Wire Size	30 to 12 AWG
Protocol	BACnet and Modbus (selectable)
Terminal Block Torque	0.5 to 0.6 N-m (0.37 to 0.44 in-lbf)
Protection Class (self-evaluated)	IP20

WARRANTY

Limited Warranty	5 years*
------------------	----------

COMPLIANCE INFORMATION

Agency Approvals	Intertek ETL Listed to UL 61010-1
------------------	-----------------------------------



Communication

Interface to control system via BACnet and Modbus protocols. BTL certified.

Microprocessor based

Microprocessor controlled for excellent stability

Modular platform

Modular platform accepts Veris AG Series sensors (sold separately)... no need to install a new GWNP when the sensor life wears out

No calibration

No calibration required...easy maintenance and worry-free operation

LEDs

Three colored LEDs - red, yellow and green - for easy status viewing

Versatile interface

Interface to DDC systems or direct fan control

APPLICATIONS

- Parking garage ventilation
- Air quality compliance
- Vehicle bays (ambulance/fire/taxi)
- Mechanical rooms
- Sally ports

The GWNP operates only when an AG Series gas sensor is installed (sold separately). Accuracy, sensitivity, setpoints, and measurement range are dependant on the AG Series sensor connected to the GWNP platform. See the AG Series sensor installation guide for details.

* The AG Series gas sensors are warranted for two years from the date of manufacture. The AG Series sensors are not included in the five-year GWNP warranty.





AG01
CO Sensor



AG01E
CO Sensor



AG02
NO₂ Sensor



AG04*
CO & NO₂ Sensor



AG05
R134a Refrigerant Sensor



AG06
R410a Refrigerant Sensor

SENSOR TYPE	Electrochemical	Electrochemical	Electrochemical	CO: Electrochemical NO ₂ : Electrochemical	Non-dispersive infrared	Non-dispersive infrared
MEASUREMENT RANGE	0 to 300 ppm	0 to 500 ppm	0 to 15 ppm	CO: 0 to 500 ppm NO ₂ : 0 to 20 ppm	0 to 2000 ppm	0 to 2000 ppm
ACCURACY	±3% of range	±5% of range	±5% of range at 25 °C	CO: ±5% of range NO ₂ : ±5% of range	±2% of range (60 to 2000 ppm)	±2% of range (60 to 2000 ppm)
OUTPUT SCALING	0 to 200 ppm	0 to 500 ppm	0 to 15 ppm	N/A	0 to 2000 ppm	0 to 2000 ppm
RESOLUTION	1 ppm	1 ppm	0.1 ppm	CO: 1 ppm NO ₂ : 0.1 ppm	1 ppm	1 ppm
SENSOR WARRANTY	2 years from manufacture date	2 years from manufacture date	2 years from manufacture date	2 years from manufacture date	2 years from manufacture date	2 years from manufacture date
LOW SETPOINT VALUE	25 or 35 ppm (switch selectable)	25 or 35 ppm (switch selectable)	1 ppm (fixed)	CO: 25 ppm (default)** NO ₂ : 1 ppm (default)**	100 ppm (fixed)**	100 ppm (fixed)**
HIGH SETPOINT VALUE	180 ppm (fixed)	180 ppm (fixed)	3 ppm (fixed)	CO: 180 ppm (default)** NO ₂ : 3 ppm (default)**	500 ppm (fixed)**	500 ppm (fixed)**
OPERATING TEMP. RANGE	-20 to 50 °C (-4 to 122 °F)	-20 to 40 °C (-4 to 104 °F)	-20 to 50 °C (-4 to 122 °F)	-20 to 40 °C (-4 to 104 °F)	-20 to 50 °C (-4 to 122 °F)	-20 to 50 °C (-4 to 122 °F)
OPERATING HUMIDITY RANGE	0 to 90% RH non-condensing	0 to 90% RH non-condensing	0 to 90% RH non-condensing	0 to 90% RH non-condensing	0 to 90% RH non-condensing	0 to 90% RH non-condensing

*The AG04 sensor works only with GWNP (protocol output) Series gas platform devices. The AG04 will not work with GWNM, GWNV or GWN1 versions of the GWN Series.

**Low and high level setpoint can be adjusted between 0 and top of range if used with a GWNP (protocol) gas platform.

DIMENSIONAL DRAWING

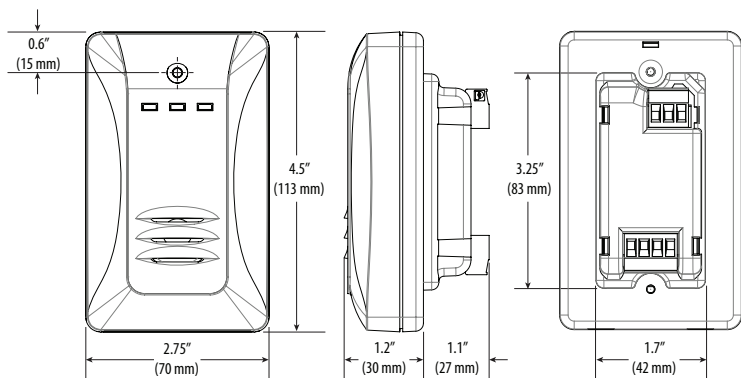

WIRING DIAGRAM

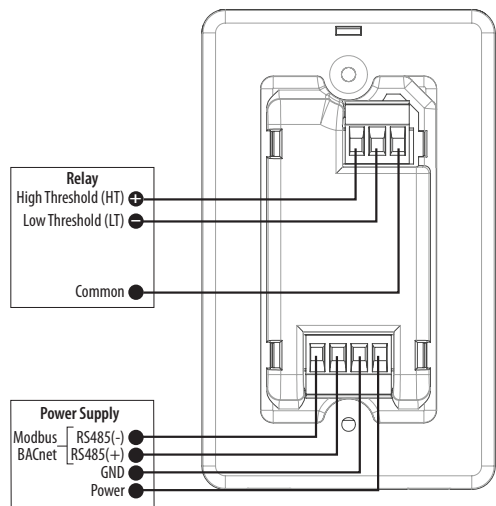

ORDERING INFORMATION - PLATFORM

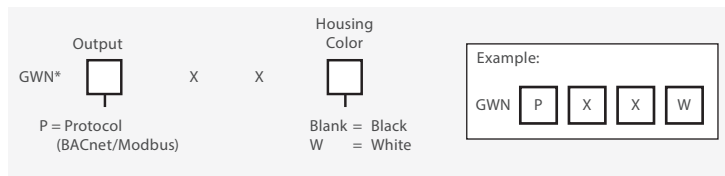

*The GWNP will not operate without an AG Series sensor installed. Sensors are sold separately.

ORDERING INFORMATION – REQUIRED SENSORS

MODEL	DESCRIPTION
AG01	CO sensor, 3% accuracy. CO sources include exhaust from gasoline powered engines, furnaces, water heaters and generators.
AG01E	CO sensor, 5% accuracy. CO sources include exhaust from gasoline engines, furnaces, water heaters and generators
AG02	NO ₂ sensor. NO ₂ sources include exhaust from diesel powered engines and generators.
AG04	CO & NO ₂ combination sensor. CO sources include exhaust from gasoline powered engines, furnaces, water heaters and generators. NO ₂ sources include exhaust from diesel engines and generators
AG05	R134a sensor. R134a is a refrigerant used in HVAC applications.
AG06	R410a sensor. R410a is a refrigerant used in HVAC applications.

Note: See Specifications section for AG sensor warranty details.

ORDERING INFORMATION – ACCESSORY ENCLOSURE

MODEL	DESCRIPTION
AGPE	Metal wall mount enclosure for the GWNP gas platform with audible horn and 10 A relay

