

H614

Automatically Learns At Initial Power-Up



H614



The Hawkeye H614 is a microprocessor based, self-learning, self-calibrating current-sensitive switching device designed for use with VFD systems. At initial power-up, the H614 automatically learns the average current on the line with no action required by the installer. Once a current is learned, the switch monitors for changes in current greater than $\pm 20\%$ of the learned load. When calibrated for a given VFD system, the H614 is tolerant of gradual drifts in frequency due to expected conditions, such as an accumulation of debris in a filter, while still detecting a sudden drop due to a potential abnormal system condition (e.g., belt loss or other mechanical failure).

SPECIFICATIONS

Sensor Power	Induced from monitored conductor
Response Time	1 sec.
Learn Time	15 sec. learn period after frequency stabilizes
Frequency Range in Conductor	12 to 115 Hz ¹
Temperature Range	-15 to 60 °C (5 to 140 °F)
Humidity Range	10 to 90% RH non-condensing
Alarm Limits	$\pm 20\%$ of learned current in every 5 Hz freq. band ²
Normal-to-Alarm Status Output Delay	Approx. 7 sec.
Alarm-to-Normal Status Output Delay	1 sec. nominal ³
Off Delay	<30 sec. nominal
Contact Ratings	30 Vac/dc, 1 A
Insulation Class	600 Vac (UL); 300 Vac RMS (CE ⁴)
Terminal Block Wire Size	24 to 14 AWG (0.2 to 2.1 mm ²)
Terminal Block Torque	3.5 to 4.4 in-lbs (0.4 to 0.5 N-m)

Microcontroller based learning technology

Automatically learns load upon initial power-up...minimizes calibration labor

Automatic trip point

Automatic trip point (1.5 to 150 Amps, 12 to 115 Hz)...detect abnormal events

Under- and over-load

Microcontroller based learning technology...automatically learns load

APPLICATIONS

- Monitoring fans, pumps, motors, and other electrical loads for proper operation
- Detecting belt loss and motor failure...ideal for fan and pump status
- Verifying lighting circuit loads
- Monitoring critical motors (compressor, fuel, etc.)
- Monitoring industrial process equipment status (OEM)

Saves space

Small size fits easily inside small starter enclosures

100% solid state

100% solid state...no moving parts to fail

Flexibility

Removable mounting bracket for installation flexibility

WARRANTY

Limited Warranty	5 years
------------------	---------

AGENCY APPROVALS

Agency Approvals	UL508 open device, CE: EN61010-1, CAT III, Pollution Degree 2
------------------	---



1. VFD systems generate fields that can disrupt electrical devices. Ensure that these fields are minimized and are not affecting the sensor.
2. The H614 is not intended for use in applications where the current is expected to fluctuate by more than 20% due to acceptable causes other than VFD driven changes.
3. If the H614 experiences a momentary loss of power, the Alarm-to-Normal output delay may exceed 1 sec.
4. The CE mark indicates RoHS2 compliance. Please refer to the CE Declaration of Conformity for additional details.

Specification Note: For CE compliance, conductor shall be insulated according to IEC 61010-1

The product design provides for basic insulation only. Use wire with minimum 75°C rated insulation. Do not use the LED status indicators as evidence of applied voltage. This sensor detects abnormal operation by looking for sudden changes in current across the entire frequency range. In Learn mode, the sensor calculates a margin 20% above and 20% below the learned frequency curve. An abnormal condition in the circuit is one that falls outside this margin.



DIMENSIONAL DRAWING

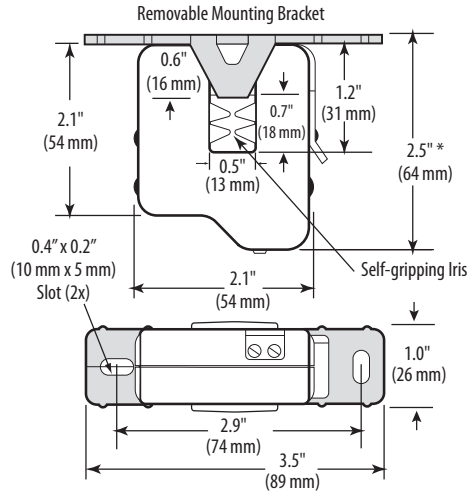

* Terminal block may extend up to 1/8" over the height dimensions shown.

WIRING DIAGRAM

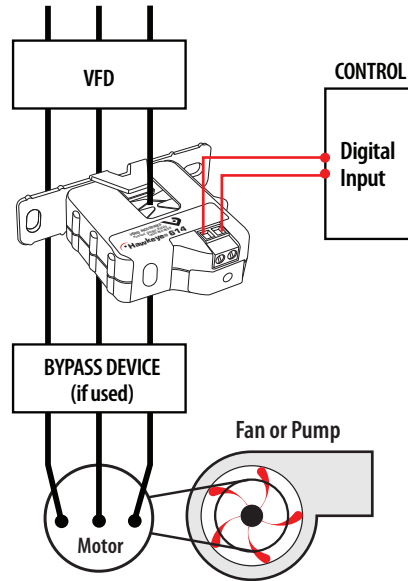

NOTE: The H614 is not intended for use in staged pump, variable inlet vane, and other applications in which the amperage changes under normal operation, independent of frequency. NOTE: (Optional) For added sensitivity in detecting amperage changes, use H614 devices on all three phases of the VFD

PRODUCT FUNCTIONS

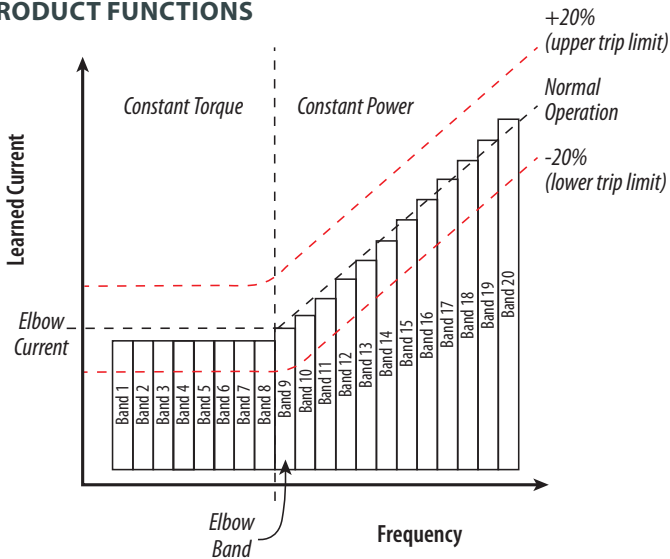

HOW IT WORKS

During setup, the H614 automatically determines the normal amperage and frequency profile and stores it in memory. Then the microprocessor monitors for amperage changes greater than $\pm 20\%$ of this learned curve, indicating a potential system failure.

ORDERING INFORMATION

MODEL	AMPERAGE RANGE	FREQUENCY RANGE	STATUS OUTPUT	NOMINAL TRIP POINT TARGET RANGE	HOUSING	STATUS LED	UL	CE
H614	1.5 to 150 A ¹	12 to 115 Hz	N.O. 1.0 A @ 30 Vac/dc	$\pm 20\%$ in each of 20 bands	Split-core	•	• ²	•

1. If the current is above 1.5 A, but neither LED is illuminated, the H614 is considered to be in on/off status mode.
 2. Listed for use on 75°C insulated conductors.

USAGE EXAMPLE

The H614 is designed for HVAC fan and blower systems, as well as some single stage pumping systems involving consistent viscosity liquids. If an H614 is installed on one phase of the VFD, it detects changes in that phase that result from the VFD compensating for changes elsewhere in the system. Alternatively, for increased sensitivity, H614s can be used on all three phases for immediate detection of phase balance changes anywhere in the system.

SENSOR MODE		STATUS LED BLINK PATTERN	CONTACTS
Learning Mode (first 15 sec of operation after frequency stabilizes)		Alternating Red/Green (1 per sec.)	Closed
On/Off Status only	Learn mode incomplete. VFD system does not meet abnormal condition detection criteria	Green blink (5 times per sec. after 15 sec of stable frequency)	Closed
	Current is not adequate for the device to detect abnormal conditions	No LED	Closed
Status OK		Green blink (1 per sec.)	Closed
Alarm		Red blink (1 per sec.)	Open

