



**Hawkeye™**

# H614

Split-Core Current Switch, Auto Calibrating,  
For VFD Applications, 12 to 115 Hz

## Product Overview

The H614 is a current-sensitive switching device designed for use with Variable Frequency Drive (VFD) systems. It is equipped with an auto calibration feature that allows the device to distinguish between a reduced amp draw due to normal changes in frequency and an abnormal drop due to belt loss or other mechanical failures.

The H614 is designed for HVAC fan and blower systems, as well as some pumping systems involving consistent viscosity liquids. If an H614 is installed on one phase of the VFD, it detects changes in that phase that result from the VFD compensating for changes elsewhere in the system. Alternatively, for increased sensitivity, H614s can be used on all three phases for immediate detection of amperage changes anywhere in the system.

A change from the normal amperage and frequency profile in the monitored conductor will cause the resistance of the FET status output to change state, similar to the action of a mechanical switch. The status output is suitable for connection to building controllers or other appropriate data acquisition equipment operating at up to 30 volts. The H614 requires no external power supply to generate its output.

Motor loads (VFD frequency and current) can change due to: outlets/inlets opening and closing; filter changes or blockage; density changes due to humidity, pressure or temperature; or other factors that affect the media being transported. This product has been programmed to detect most abnormal conditions due to changes in motor loads. If false alarms occur please see the Troubleshooting section of this document.

Performance of the H614 can be optimized through an optional step. When the H614 is first powered and is in Learn Mode, manually cycle through each 5 Hz frequency band, allowing the VFD to remain at each band for 15 seconds.

## Specifications

<b>Sensor Power</b>	Induced from monitored current
<b>Amperage Range</b>	1.5 to 150 A Continuous*
<b>Status Output</b>	N.O. 1.0 A @ 30 Vac/dc
<b>Response Time</b>	1 second
<b>Learn Time</b>	15 seconds after frequency ramping stabilizes
<b>Frequency</b>	12 to 115 Hz
<b>Temperature Range</b>	-15° to 60°C (5° to 140°F)
<b>Humidity Range</b>	10 to 90% RH non-condensing
<b>Alarm Limits</b>	±20% of learned current in every 5 Hz freq. band
<b>Normal-to-Alarm Status Output Delay</b>	5 sec. max.
<b>Alarm-to-Normal Status Output Delay</b>	1 sec. nominal **
<b>Off Delay</b>	<30 sec. (nominal)
<b>Contact Ratings</b>	30 Vac/dc, 1 A
<b>Insulation Class</b>	600 Vac (UL); 300 Vac (CE)
<b>Terminal Block Wire Size</b>	24 to 14 AWG (0.2 to 2.1 mm <sup>2</sup> )
<b>Terminal Block Torque</b>	3.5 to 4.4 in-lbs (0.4 to 0.5 N-m)
<b>Agency Approvals</b>	UL 508, CE: EN61010-1, Installation Category III, pollution degree 2

\* If the current is above 1.5 A, but neither LED is illuminated, the H614 is considered to be in on/off status mode.

\*\* If the H614 experiences a momentary loss of power, the Alarm-to-Normal output delay may exceed 1 sec.

Specification Note: For CE compliance, conductor shall be insulated according to IEC 61010-1:2001.

The product design provides for basic insulation only. Use wire with minimum 75°C rated insulation. Do not use the LED status indicators as evidence of applied voltage.

This sensor detects abnormal operation by looking for sudden changes in current across the entire frequency range. In Learn mode, the sensor calculates a margin 20% above and 20% below the learned frequency curve. An abnormal condition in the circuit is one that falls outside this margin.



### ⚠️ DANGER

- HAZARD OF ELECTRIC SHOCK, EXPLOSION, OR ARC FLASH**
- Follow safe electrical work practices. See NFPA 70E in the USA, or applicable local codes.
  - This equipment must only be installed and serviced by qualified electrical personnel.
  - Read, understand and follow the instructions before installing this product.
  - Turn off all power supplying equipment before working on or inside the equipment.
  - Product may use multiple voltage/power sources. Disconnect ALL sources before servicing.
  - Use a properly rated voltage sensing device to confirm that power is off. DO NOT DEPEND ON THIS PRODUCT FOR VOLTAGE INDICATION.
  - Current transformer secondaries must be shorted or connected to a burden at all times.
  - Products rated only for basic insulation must be installed on insulated conductors.
  - Replace all doors, covers and protective devices before powering the equipment.
- Failure to follow these instructions will result in death or serious injury.**

A qualified person is one who has skills and knowledge related to the construction and operation of this electrical equipment and installations, and has received safety training to recognize and avoid the hazards involved. NEC Article 100  
If this product is used in a manner not specified by the manufacturer, the protection provided by the product may be impaired. No responsibility is assumed by the

### NOTICE

- This product is not intended for life or safety applications.
- Do not install this product in hazardous or classified locations.
- The installer is responsible for conformance to all applicable codes.
- Mount this product inside a suitable fire and electrical enclosure.

\* The CE mark indicates RoHS2 compliance. Please refer to the CE Declaration of Conformity for additional details.

## Dimensions

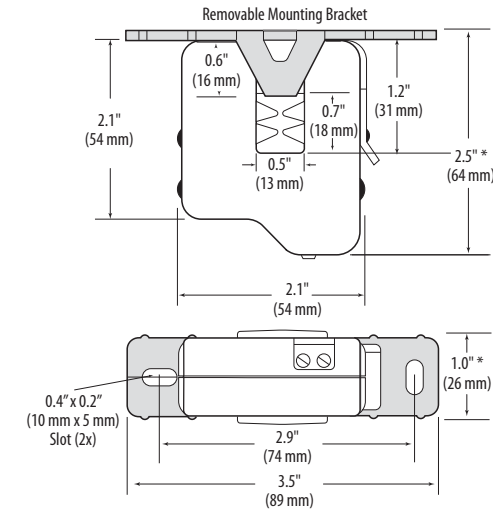

## Installation

- Establish normal operating conditions for the VFD (**clean filter, normal load, etc.**).
- Disconnect and lock out power to the VFD, the enclosure, and the conductor to be monitored.
- Choose a location for the sensor. The monitored conductor must pass through the center window, and the sensor must be at least 1/2" from any uninsulated conductors. Mount the sensor on the load side output conductor of the VFD. Do not install on VFD input power conductors. If using a bypass system, place the H614 between the VFD and the bypass device.
- Install the mounting bracket in the enclosure using the included screws.
- Wire the connections between the sensor and the controller.
- Snap the sensor over the conductor to be monitored. Snap the unit with the bracket latched securely to ensure proper operation.
- Restore power to the VFD and the conductor.
- As the VFD frequency ramps up, the sensor enters Learn mode. The LED will blink (alternating red-green).
- 15 seconds after the VFD frequency ramping is complete, the sensor self-calibration is finished. The LED will blink (green only).

Note: If the VFD current does not change during the Learn mode period, the sensor will not learn normal conditions. The LED will blink (green, 5 times per second) to indicate the sensor is in Status Only mode, monitoring the circuit for on/off status.

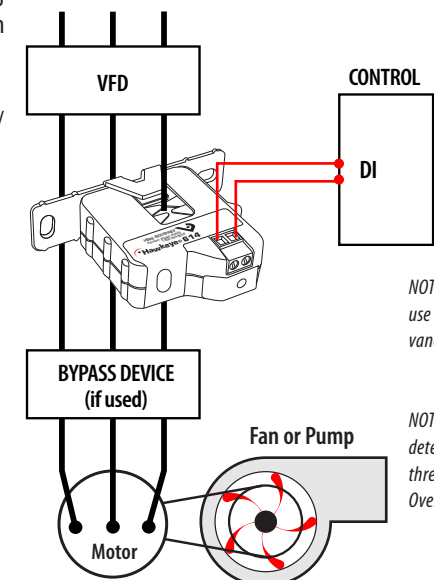

NOTE: The H614 is not intended for use in staged pump or variable inlet vane applications.

NOTE: (Optional) For phase loss detection, use H614 devices on all three phases of the VFD (see Product Overview section for details).

## Notes

### For load currents less than sensor minimum rating:

Wrap the monitored conductor through the center window and around the sensor body to produce multiple turns. This increases the current measured by the transducer. Program the controller to account for the extra turns (e.g., if four turns pass through the sensor (as shown) divide the normal reading by 4).

< 1.5 A (Sensor Min.)

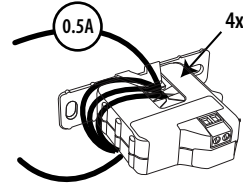

**NOTICE**

**RISK OF EQUIPMENT DAMAGE**

- Derate the product's maximum current for the number of turns through the current sensor window using the following formula:  
 $\text{Rated Max. Amps} \div \text{Number of Turns} = \text{Max. monitored Amps}$   
 e.g.:  $100\text{A} \div 4 \text{ Turns} = 25 \text{ Amps max. in monitored conductor}$
- Never exceed the current sensor rating.
- Failure to follow these instructions can result in overheating and permanent equipment damage.

## Status LEDs

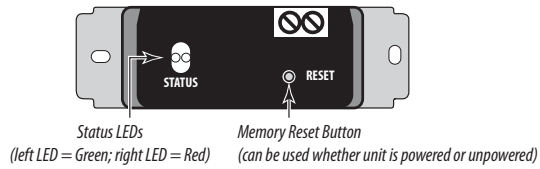

Sensor Mode		Status LED Blink Pattern
Learning Mode (first 15 sec of operation after frequency stabilizes)		Alternating Red/Green (1 per sec.)
On/Off Status only	Learn mode incomplete. VFD system does not meet abnormal condition detection criteria	Green blink (5 times per sec. after 15 sec of stable frequency)
	Current is not adequate for the device to detect abnormal conditions	No LED when status output is closed. Note: if status output is open and no LEDs are illuminated, see the Troubleshooting section.
Status OK		Green blink (1 per sec.)
Alarm		Red blink (1 per sec.)

## Memory Reset

During setup, the H614 automatically determines the normal amperage and frequency profile and stores it in memory. The H614 requires a memory reset to clear the learned values from memory if any of the following conditions occur:

- The sensor is reinstalled on a different motor.
- The motor is re-sheaved.
- The system is air balanced or air duct restrictions change
- The motor load changes significantly (e.g., filter changes).

To reset the H614:

- Establish normal operating conditions for the monitored conductor (e.g. clean air filters, close duct access doors).
- The reset button has two positions, in and out. Push the button until there is a noticeable click to change the position. This causes a change of state, which triggers the reset function. The nonvolatile memory is erased and the H614 enters the learning mode (LEDs blink red/green) to learn the new amperage profile of the monitored conductor.

**Note:** The reset function can be performed even if the H614 is not installed on a conductor. Pushing the button (changing the state) will clear the learned values from memory immediately if powered, otherwise at the next power-up.

**Note:** For normal operation, this button can be in either the in or out position.

## Troubleshooting

Problem	Solution
Status output open with current above 1.5 A, with no alarm condition	<ul style="list-style-type: none"> <li>Check for amperage in monitored conductor (&gt;1.5 A).</li> <li>Check that amperage in the monitored conductor does not exceed sensor max (150 A).</li> <li>Ensure that no more than 30 VAC/DC or 1.0 A has passed through the contact. Voltages or currents above these levels will damage the unit.</li> <li>Ensure that sensor core mating surfaces are clean and that the core clamp is completely closed.</li> <li>Ensure that the sensor is operating within specified temperature range.</li> <li>Ensure that the sensor has completed Learn mode. If it has not, check circuit parameters and compliance.</li> <li>If the conditions listed above are satisfactory, contact Veris Customer Support as listed in the footer of this document.</li> </ul>
Unusual readings on VFD outputs	Check all internal VFD wiring connections for proper tightness according to the manufacturer instructions.
False alarms	Perform Memory Reset (see Memory Reset section and the listed conditions). Note: During initial start-up/usage, the product can store the normal current values for up to 20 different frequencies from 12 to 115 Hz. When the frequency is encountered again, the present current is compared to the learned current. In most cases, the current is considered abnormal if it varies by greater than about 20% of the learned current. This provides a valuable warning of abnormal conditions for most VFD applications. If the application experiences abnormal swings in current/frequency, this product may not be a good match. However, a current switch (i.e., H600, H608, etc.) can provide a single-point on/off status.

