

H738



Hawkeye™ 738

Solid-Core Current Switch, Adjustable Trip Point With Command Relay

Installer's Specifications

Amperage Range	1-135 A continuous
Sensor Power	Induced from monitored current
Insulation Class	600 VAC RMS
Frequency Range	50/60 Hz
Temperature Range	-15° to 60°C (5° to 140°F)
Humidity Range	10-90% RH non-condensing
Hysteresis	10% of setpoint, typical
Terminal Block Maximum Wire Size	14 AWG
Terminal Block Torque (nominal)	4 in-lbs (0.45 N-m)
Status Output	N.O. 1.0 A@30 VAC/DC
Relay Coil	24 VAC/DC, 10 mA
Relay Contact	Resistive: 10 A@250 VAC, 30 VDC; Inductive: 5 A@250 VAC, 30 VDC
Agency Approvals	UL508 E150462

⚠ DANGER ⚡

HAZARD OF ELECTRIC SHOCK, EXPLOSION, OR ARC FLASH

- Follow safe electrical work practices. See NFPA 70E in the USA, or applicable local codes.
- This equipment must only be installed and serviced by qualified electrical personnel.
- Read, understand and follow the instructions before installing this product.
- Turn off all power supplying equipment before working on or inside the equipment.
- Use a properly rated voltage sensing device to confirm power is off.
DO NOT DEPEND ON THIS PRODUCT FOR VOLTAGE INDICATION
- Only install this product on insulated conductors.

Failure to follow these instructions will result in death or serious injury.

NOTICE

- This product is not intended for life or safety applications.
- Do not install this product in hazardous or classified locations.
- The installer is responsible for conformance to all applicable codes.
- Mount this product inside a suitable fire and electrical enclosure.

*Do not use the LED status indicators as evidence of applied voltage.
The product design provides for basic insulation only.*

INSTALLATION

Disconnect and lock out power to the enclosure containing the conductor to be monitored.

1. Locate a mounting surface for the removable mounting bracket that will allow the monitored conductor to pass through the center window when it is installed and that will keep the device at least 1/2" from any uninsulated conductors. Determine cable routing for the controller connection, allowing wiring to reach the mounting location.
2. Route the conductor through the sensor's center window and slip the assembly into the mounting bracket. Terminate the conductor. See Notes (page 2) for currents under 1 Amp or above 135 Amps.
3. Wire the output connections to the DDC controller or switched load (solid state contact).
4. Secure enclosure and reconnect power.
5. Calibrate the sensor (see Calibration section).

DIMENSIONS

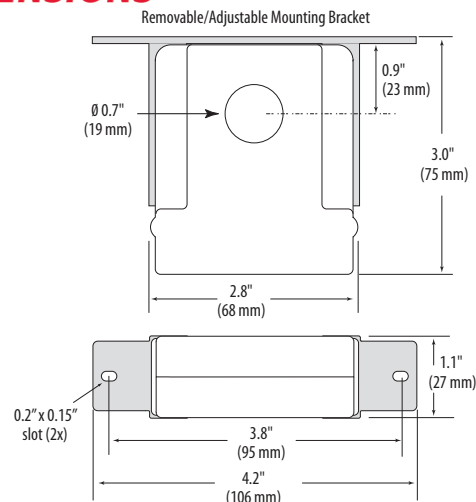

WIRING EXAMPLE

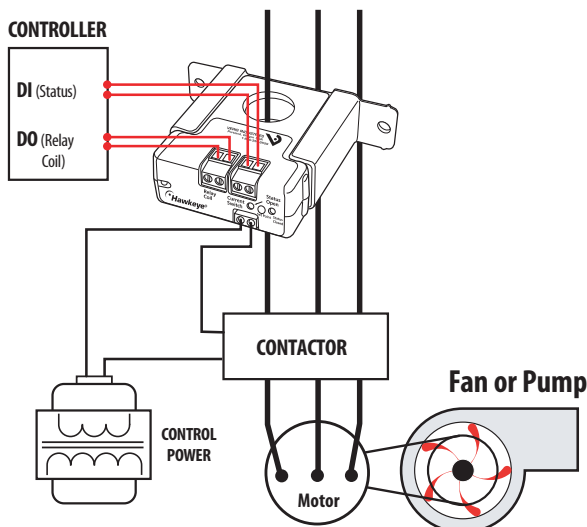

OPERATION

The H738 is a current-sensitive switching device that monitors current (amperage) in the conductor passing through it. A change in the conductor's amperage that crosses the adjustable switch threshold plus the hysteresis value causes the resistance of the FET status output to change state, similar to the action of a mechanical switch. In this model, the setpoint is adjustable through the action of a twenty (20) turn potentiometer (see the CALIBRATION section). An integrated relay allows start/stop control. The status output is suitable for connection to building controllers or other appropriate data acquisition equipment operating at up to 30 volts. The H738 requires no external power supply to generate its output.

NOTES

For load currents greater than sensor maximum rating:

Use a 5 Amp (H68xx series) Current Transformer (CT) as shown. This technique can be combined with wrapping (see below) to add range for a low current load on a high current source.

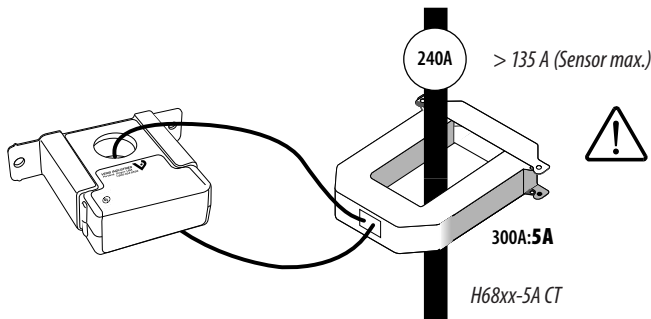

! DANGER: 5A CTs can present hazardous voltages. Install CTs in accordance with manufacturer's instructions. Terminate the CT secondary before applying current.

CAUTION

RISK OF EQUIPMENT DAMAGE

- Derate the product's maximum current for the number of turns through the sensing window using the following formula.

$$\text{Rated Max. Amps} \div \text{Number of Turns} = \text{Max. monitored Amps}$$
 e.g. : $100A \div 4 \text{ Turns} = 25 \text{ Amps max. in monitored conductor}$
- Failure to follow these instructions can result in overheating and permanent equipment damage.

For load currents less than sensor minimum rating:

Wrap the monitored conductor through the center window and around the sensor body to produce multiple turns. This increases the current measured by the transducer.

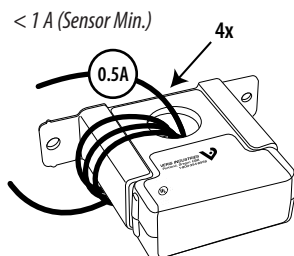

CALIBRATION

Before beginning calibration, establish normal load conditions.

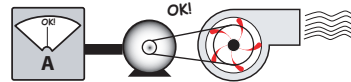

Then choose either A or B below.

A. To monitor under-current (belt loss, coupling shear, status)

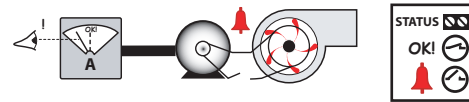

1. Turn setpoint screw clockwise until Status OPEN LED turns ON.

2. Slowly turn the screw counter-clockwise until the Status CLOSED LED just turns ON.



B. To monitor over-current (mechanical problems, seized impeller)

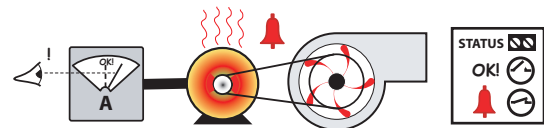

1. Turn setpoint screw counter-clockwise until Status CLOSED LED turns ON.

2. Slowly turn the setpoint screw clockwise until the Status OPEN LED just turns ON.

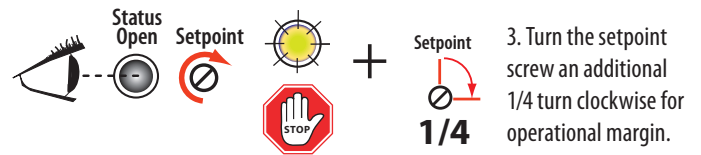

TROUBLESHOOTING

Problem	Solution
No Reading at Controller	<ul style="list-style-type: none"> • Check sensor calibration (see above) • Check for control voltage at sensor (< 30 V) • Check for amperage in monitored conductor (> 1 A)
Setpoint screw has no stops	The setpoint screw has a slip-clutch at both ends of its travel to avoid damage. Twenty turns CCW will reset the sensor to be most sensitive. Repeat calibration above.
Both LEDs are lit	Setpoint screw is too far clockwise. See solution above.